



PRODUCT CATALOG

TOTAL LUBRICATION MANAGEMENT SOLUTIONS



TABLE OF CONTENTS

Introduction to Trico A1

Constant Level Lubrication B1

Opto-Matic® Constant Level Oilers	B2–B3
Breather Tubes	B4
Opto-Matic® Closed System Oilers	B6
Watchdog® Oilers	B7
Opto Laser Level	B8

Pressure Differential Products C1

Equalizer Expansion Chambers	C2
Selection of an Expansion Chamber	C3

Visual Inspection Units D1

Sump Bottles	D2
Liquid Level Gauges	D3–D4
Viewports	D5

Oil Sampling/Analysis E1

Oil Sampling Ports	E2
Pitot Tube Sampling Ports	E3
Liquid Level Gauge Sample Ports	E4
Vacuum Pump & Sampling Accessories	E5
Reservoir Breather Kits	E6–E7

Moisture Removal F1

Watchdog® Desiccant Breathers	F2–F3
Watchdog® EX Series Breathers	F4
Watchdog® R Series Breathers	F5
Watchdog® Breather Adapters	F6
Watchdog® Oil Dryer	F7

Filtration Systems G1

High-Viscosity Gear & Lube Oil Filtration System	G1–G2
Pneumatic High-Viscosity Filtration System	G3–G4
Low-Viscosity Filtration System	G5–G6
Drum Pump Filtration System	G7–G8

Spectrum Visual Lubrication Management H1

Spectrum Tags & Labels	H2–H3
Spectrum Oil Storage System	H4–H5
EZI-action Drum Pumps	H6
Spectrum® Oil Containers	H7–H8
Spectrum Grease Identification Products	H9
Spectrum Opto-Matic Collars	H10
Industrial Fast Funnel	H11

Safety I1

Oil Absorbents	I2
--------------------------	----

Gravity Feed Oilers J1

Gravity Feed Oilers	J2
Atlas Gravity Feed Oilers	J3
PC Oil Cup	J4
Vari-Feed Wick Oilers	J5
D & DE Full Flow Dispensers	J6
V Series Valves & VM Manifolds	J7
ST Series Valves & S Series Applicator	J8

Applicators	J9
-----------------------	----

Grease Lubrication Products K1

Streamliner® Electro-Mechanical Grease Dispensers	K2–K3
Streamliner® M 500cc Grease Dispensers	K4
Streamliner® Electro-Mechanical Accessories	K5
Streamliner® DC Electro-Chemical Grease Dispensers	K6
Streamliner® Electro-Chemical Grease Dispensers	K7
Streamliner® S Grease Dispensers	K8
Streamliner® Mechanical Grease Dispensers	K9
Grease Meter	K10

Central Lubrication L1

Basic Types of Systems	L2
Positive Displacement Injectors	L3
Pumps for PDI Systems	L4
PM-10 & 20 Series Manual Cyclic Pumps	L5
PE-10 & 12 Series Automatic Cyclic Pumps	L6
PE-20, 22 & 24 Series Automatic Cyclic Pumps	L7
PE-30 & PE-32 Series Automatic Cyclic Pumps	L8
PE-40 & PE-50 Series Continuous System Pumps	L9
Meter & Control Units	L10
Fittings	L11–L12
Fittings & Hoses	L13
Accessories	L14
Technical Information	L15
Using the System Design Worksheet	L16–L17
System Design Worksheet	L18
Product Selection Charts	L19
Distribution Network Design	L20–L21

Minimum Quantity Lubrication M1

MD-1200 Micro-Drop®	M2–M3
-------------------------------	-------

Spray Cooling N1

DL & DL Magnum	N2
Li'l Mister® Systems	N3
Spraymaster®	N4
Spraymaster® II	N5
Mismatic® Coolant Delivery Systems	N6
Coolant Delivery Systems	N7–N8

Lubricants & Coolants O1

Tri-Cool® Fluids	O2–O3
----------------------------	-------

Lab Instrumentation P1

Direct Reading Ferrograph	P1
Ferrogram Maker	P2
Ferroscope FS-6	P3
Digital Camera	P4

Services Q1

◆ In the selection charts on the following pages, units with inch threads are indicated with red model numbers, and metric units with green model numbers.



Trico reserves the right to change product specifications without prior notice.

Cat. No. 60007 11/12 ©Copyright Trico Corp. 2014

TOTAL LUBRICATION MANAGEMENT SOLUTIONS

TRICO: TOTAL LUBRICATION MANAGEMENT SOLUTIONS.

Trico—the worldwide leaders in predictive lubrication management—have combined capabilities to become your complete resource for the services and products you need to keep your equipment running productively—around the clock.

With facilities in Pewaukee, Wisconsin, and Cleveland, Ohio, and worldwide distribution services—we offer global solutions on a local level.

Whether you're looking for an assessment of your lubrication maintenance procedures, an audit of your entire facility, training for employees or simply the most complete line of high-performance lubrication management products in the country—we have your solution.

SERVICES

- Consulting
- Training
- Auditing
- Assessments
- Oil Monitoring and Analysis

PRODUCTS

- Constant Level Lubrication
- Desiccant Breathers
- Oil Sampling
- Moisture Removal Systems
- Fluid Handling Systems
- Gravity Feed Oilers
- Grease Lubrication
- Central Lubrication
- Filtration Systems and Carts
- Lab Instrumentation
- Spray Cooling and Minimum Quantity Lubrication

For more than 95 years, we have provided clients with a focus on industrial equipment performance and reliability. We've done this by combining high-performance lubrication products, with our nationally-recognized proactive lubrication management training, auditing, and consulting programs.



INTRODUCTION TO CONSTANT LEVEL LUBRICATION

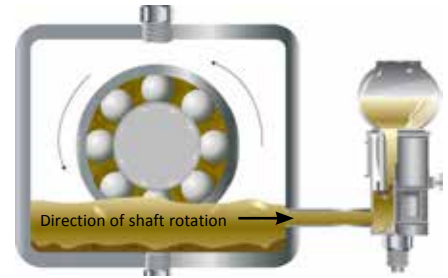
Constant level oilers are designed to maintain a predetermined oil level in a sump, which is necessary for proper lubrication. If the oil level were to drop below this point, the depleted oil would automatically be replenished by the lubricator, returning it to its original level. With the use of constant level oilers, maintenance efficiencies can be increased, while minimizing maintenance costs, and the loss of production time.

The majority of constant level oilers available are adjustable, allowing for use in many applications. However, there are oilers available that do not allow for fluid level adjustability, eliminating potential installation errors. Typically, constant level oilers are mounted on the side of the equipment facing the direction of shaft rotation. Some oilers allow for bottom mounting, on the oil sump, which prevents the oiler from misfeeding during applications that contain currents and turbulence formed by slinger rings, discs, and high rotating speeds.

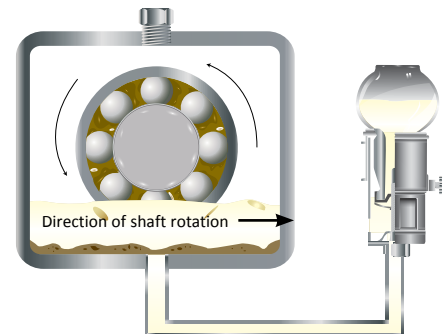
In most cases constant level oilers are vented to the outside atmosphere to work properly. Since these oilers are vented to the atmosphere, especially in harsh, dirty environments, contaminants are allowed to enter the lubricating oil. These contaminants are in the forms of moisture and/or particulate which are extremely damaging to oil and equipment life.

In order to combat the potential for oil contamination, the closed system oiler was developed. These oilers are effective in minimizing and eliminating the ingress of contaminants into the oil sump, especially in dirty environments. Some closed system oilers contain a pressure balancing line, which is connected from the headspace of the oil sump to an air chamber built into the surge body of the oiler. This air chamber is sealed from the outside atmosphere in order to prevent the ingress of contaminants. Additional types of closed system oilers are available that mount directly on the centerline of the oil level to be maintained. The exchange of air between the oil sump and the oiler is at the oilers base, which is mounted directly to the oil sump.

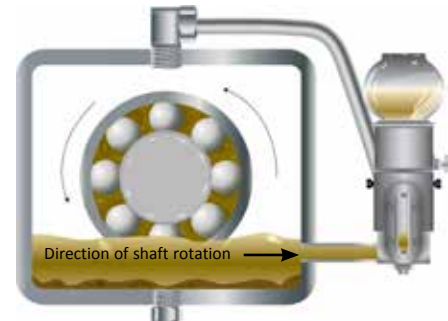
Several different types of constant level oilers are available to meet specific application needs, whether it is vented or non-vented, adjustable or nonadjustable they are an easy and effective method of maintaining proper oil level in equipment.



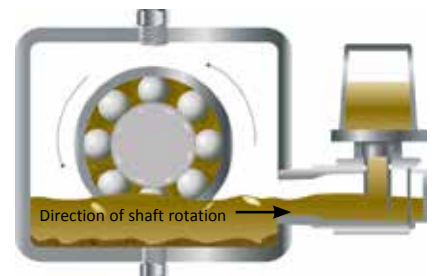
Vented constant level oiler with side connection



Vented constant level oiler with bottom connection



Closed system oiler with pressure balancing line



Closed system oiler mounted on center line of desired oil level



OPTO-MATIC® CONSTANT LEVEL OILERS



Opto-Matic Oilers provide an inexpensive method to automatically maintain a constant level of oil in a pump bearing housing, gear box, or other oil sump applications. Throughout processing industries, the Opto-Matic Oiler is the industry standard. Different reservoir capacities allow use in many applications.

Stainless steel models provide long life in corrosive environments in the chemical, pulp and paper, and mining industries.

FEATURES

- One piece glass reservoir ensures proper constant level function. Compared to competitive models, there is no possibility of air leakage that would cause overflowing of the bearing housing.
- Adjustable level setting allows use in many applications
- Multiple air vent slots provide for proper functioning at all times
- Large surge chamber helps prevent overflow of oil during machine start-up or shut-down
- Side and bottom connections for simplified installation

WIRE GUARDS

Wire guards are ordered separately and are customer installed.

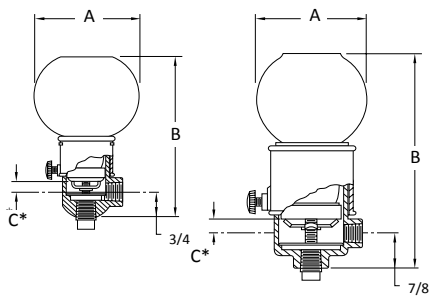


Model No. Standard	Model No. Stainless Steel	Description
30012	—	2-1/2 oz. Guard
30013	30313	4 oz. Guard
30016	30315	8 oz. Guard
30020	30320	16 oz. Guard

SPECIFICATIONS

	Standard	316 Stainless Steel
Max. Operating Temp.	250°F Continuous	
Reservoir	One-Piece Glass Bottle	
Casting	Zinc	316 Stainless
Finish	Zinc/Chromate Plated	Passivated
Internal Parts	Zinc Plated Steel	
O-ring	Viton®	

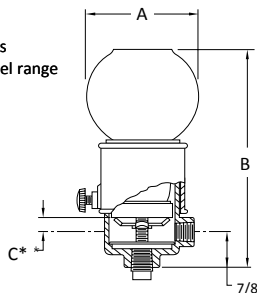
Viton® is a registered trademark of Du Pont Dow Elastomers.



No. 30002 Standard

No. 30003, 30005, and 30010 Standard

* "C" dimensions represent oil level range



Connection Side and Bottom Stainless Steel

SELECTION CHART—STANDARD

Model No.	Capacity	Connection (NPT)	Dimensions (in.)				
			A	B Min.	B Max.	C Min.	C Max.
30002	2-1/2 oz.	1/4	2-1/2	3-15/16	4-1/4	11/32	9/16
30003	4 oz.	1/4	2-11/16	5	5-3/4	9/32	1
30005	8 oz.	1/4	3-3/16	5-15/16	6-11/16	9/32	1
30010	16 oz.	1/4	4-1/8	6-13/16	7-9/16	9/32	1

* Metric thread sizes available. Add "-M" to part number for 1/4 BSPT connection port.

SELECTION CHART—316 STAINLESS STEEL

Model No. With Side & Bottom Connect	Capacity	Connection (NPT)	Dimensions (in.)				
			A	B Min.	B Max.	C Min.	C Max.
30213	4 oz.	1/4	2-11/16	4-15/16	5-11/16	9/32	1
30215	8 oz.	1/4	3-3/16	5-7/8	6-5/8	9/32	1
30220	16 oz.	1/4	4-1/8	6-3/4	7-1/2	9/32	1

* Metric thread sizes available. Add "-M" to part number for 1/4 BSPT connection port.

See Spectrum Opto-Matic Collars on page H10 for color coding options.



OPTO-MATIC® CONSTANT LEVEL OILERS

Opto-Matic Oilers provide a constant level of oil in a pump bearing housing, gear box, or other oil sump applications. Different reservoir capacities allow use in many applications.

“LS”, “EH”, and “EHB” models have a large surge chamber to minimize potential of leakage during oil surge conditions.

FEATURES

- High strength, transparent, ribbed plastic reservoir provides long life and impact resistance
- Adjustable level setting allows use in many applications
- Multiple air vent slots provide for proper functioning at all times
- Large surge chamber (LS, EH, and EHB models) prevents overflow of oil during machine start-up or shut-down
- Side and bottom connections for simplified installation



SPECIFICATIONS

Max. Operating Temp.	165°F Continuous
Reservoir	Butyrate Plastic
Casting	Zinc Die Cast
Finish	Bright Zinc Plated
Internal Parts	Zinc Plated Steel

SELECTION CHART—E, EB

Model No.		Capacity	Connection (NPT)	Dimensions (in.)				
E	EB			A	B Min.	B Max.	C Min.	C Max.
30052	30062	2 oz.	1/4	1-15/16	3-7/8	4-3/8	1/4	3/4
30054	30064	4 oz.	1/4	2-5/16	4-9/16	5-1/16	1/4	3/4
30058	30068	8 oz.	1/4	2-5/8	5-11/16	6-3/16	1/4	3/4

* Metric thread sizes available. Add “-M” to part number for 1/4 BSPT connection port.

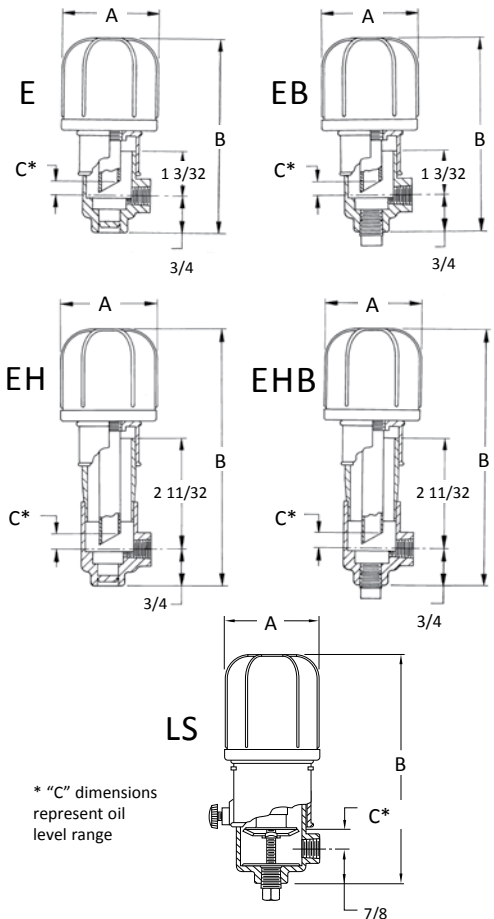
SELECTION CHART—EH, EHB (large surge chamber)

Model No.		Capacity	Connection (NPT)	Dimensions (in.)				
EH	EHB			A	B Min.	B Max.	C Min.	C Max.
30072	30082	2 oz.	1/4	1-15/16	5	5-1/2	1/4	3/4
30074	30084	4 oz.	1/4	2-5/16	5-11/16	6-3/16	1/4	3/4
30078	30088	8 oz.	1/4	2-5/8	6-13/16	7-5/16	1/4	3/4

SELECTION CHART—LS (large surge chamber)

Model No.	Capacity	Connection (NPT)	Dimensions (in.)				
A	B Min.	B Max.	C Min.	C Max.			
30024	4 oz.	1/4	2-5/16	5-7/16	6-3/16	9/32	1
30028	8 oz.	1/4	2-5/8	6-9/16	7-5/16	9/32	1

* Metric thread sizes available. Add “-M” to part number for 1/4 BSPT connection port.



See Spectrum Opto-Matic Collars on page H10 for color coding options.

BREATHER TUBES

Breather tubes are accessories used in conjunction with vented Opto-Matic® Oilers to help eliminate vacuums created by abnormally tight bearings or pressures created by high speed bearings. The breather tube helps maintain a constant atmospheric pressure in the bearing housing.

SELECTION CHART

Model No.	Description	
30014	Type "C"	1/8 NPT Thread Wick Filter
30015	Type "E"	1/8 NPT Thread Dust Cap

Breather tubes are available for customer installed vent ports in bearing housing or piping lines.

HELPFUL TIP:

Breather tubes are ideal for use in environments that contain minimal contaminants. If contamination is a concern, the Watchdog Desiccant Breathers are an excellent choice for removing contaminants as well as allowing the equipment to breathe.



OPTO-MATIC® CLOSED SYSTEM OILERS

The Opto-Matic Closed System Oiler is designed for all types of equipment where a constant level in an oil sump must be maintained. The closed system design prevents contamination and spillage. The adjustable collar allows the oil level to be externally adjusted to the desired level. A 1/8 NPT port is provided for a vent line back to the housing to allow pressure balancing between the oiler and the housing.

FEATURES

- One piece glass reservoir ensures proper constant level function. Compared to competitive models, there is no possibility of air leakage that would cause overfilling of the housing.
- Adjustable level setting allows use in many applications
- Bottom of adjusting collar indicates actual oil level setting for easy set-up and maintenance
- Side and bottom connections for simplified installation
- 2" sight gauge for easy viewing of oil level



SELECTION CHART

Model No.	Capacity	Dimensions (in.)			
		A	B Min.	B Max.	NPT
30203	4 oz.	2-11/16	7-1/6	7-13/16	1/4
30205	8 oz.	3-3/16	8	8-3/4	1/4
30210	16 oz.	4-1/8	8-7/8	9-5/8	1/4

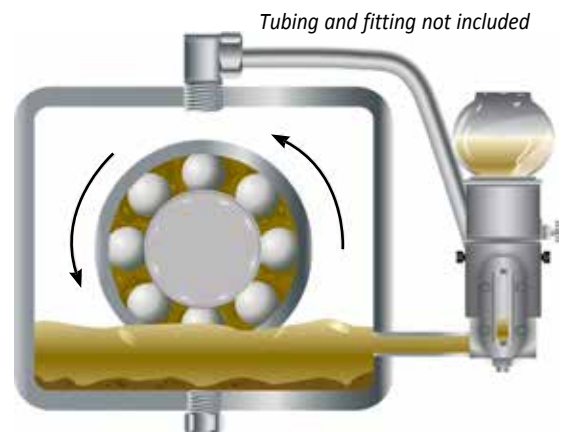
SPECIFICATIONS

Max. Operating Temp.	250°F Continuous
Reservoir	One-Piece Glass Bottle
Upper Casting	Zinc
Lower Body	Zinc
Adjusting Collar	Zinc
O-Ring	Vilton®

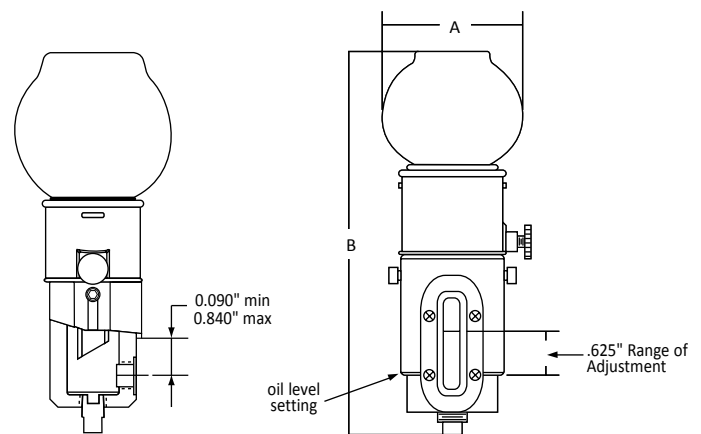
WIRE GUARDS

Wire guards are ordered separately and are customer installed.

Model No.	Description
30013	4 oz. Guard
30016	8 oz. Guard
30020	16 oz. Guard



Opto-Matic closed system oiler with pressure balancing line



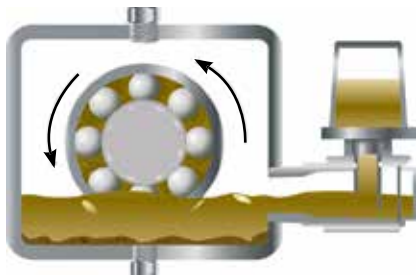
See Spectrum Opto-Matic Collars on page H10 for color coding options.

WATCHDOG® OILERS

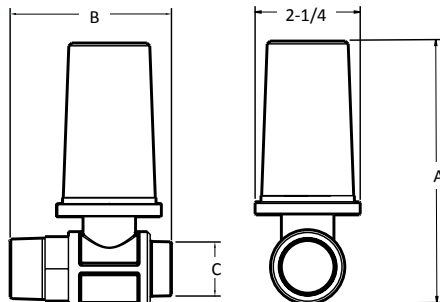
The Watchdog Closed System Oiler is designed for bearing housings, gear boxes, and other oil sump applications. It is ideal for use in the chemical processing, power generation, pulp and paper, and utility industries. The viewport provides visual indication of lubricant level and condition. Mounted on the centerline of the desired oil level, these constant level oilers do not require any adjustment or level setting.

FEATURES

- Closed system design prevents contamination and spillage
- No vent line to pump bearing housing required, simplifying installation
- 4 oz. reservoirs provide oil make-up
- Mounts on centerline of desired oil level, and does not require adjustment or level setting
- Integral viewport eliminates need for additional component



Watchdog Oiler mounted on centerline of desired oil level



SPECIFICATIONS

	Aluminum Body	Thermoplastic Body	Stainless Steel Body
Body	Cast Aluminum	Polysulfone	316 Stainless Steel
Reservoir	Glass	Polysulfone	Glass
Viewport	Glass	Polysulfone	Glass
Max. Operating Temp.	325°F/160°C	325°F/160°C	325°F/160°C
O-Ring	Viton®	Viton®	Viton®

SELECTION CHART

Model No.	Style	Capacity	Connection	Wire Guard	Dimensions (in.)		
					A	B	C
31804	Thermoplastic Body, Reservoir and Viewport	4 oz.	1 NPT	No	5-3/4	3-9/32	1
31818	Aluminum Body, Glass Reservoir and Viewport	4 oz.	1/2 NPT	No	6-1/4	4-1/8	1/2
31820		4 oz.	3/4 NPT	No	6-1/4	3-1/4	3/4
31821		4 oz.	1 NPT	No	6-1/4	3-1/4	1
31822		4 oz.	3/4 BSPT	No	6-1/4	4-1/8	3/4
31823		4 oz.	1 BSPT	No	6-1/4	3-1/4	1
31824		4 oz.	3/4 NPT	Yes	6-1/2	3-3/8	3/4
31825		4 oz.	1 NPT	Yes	6-1/2	3-3/8	1
31826		4 oz.	3/4 BSPT	Yes	6-1/2	4-1/8	3/4
31827		4 oz.	1 BSPT	Yes	6-1/2	3-3/8	1
31831		316 Stainless Steel Body, Glass Reservoir and Viewport	4 oz.	1 NPT	No	6-1/4	3-1/4
31833	4 oz.		1 NPT	Yes	6-1/2	3-3/8	1



OPTO LASER LEVEL

Trico's Opto Laser Level is an innovative tool that allows for quick and easy installation of the Opto-Matic Constant Level Oiler.

With the Opto Laser Level, installation of the Opto-Matic Oiler just became more user-friendly. In conjunction with the Opto-Matic Oiler, the Opto Laser Level will produce an immediate impact on your lubrication program.

Trico gives you even more with this quick, convenient and accurate method of installing the oiler – minimizing installation, reducing downtime and eliminating confusion. The Opto Laser Level is a must for every maintenance department responsible for set-up and upkeep of equipment that uses Opto-Matic Oilers.

FEATURES

- **Reusable** – The Opto Laser Level can be used to install multiple Opto-Matics in your plant
- **Lightweight** – Weighing 0.55 lbs, this tool fits in your hand for those hard to reach installation areas
- **Easy to Read** – Take the guess work out of installation with laser level alignment and visual level indicators
- **Portable** – Each Opto Laser Level comes in water-tight, foamed-lined, hard case with a handle for safe storage and convenient when transporting to the installation site



SPECIFICATIONS

Material	Aluminum Die Cast
Finish	Powder Coated
Components	Stainless Steel
Battery Type	CR123
Battery Life	50 Hrs
Laser Class	Class IIIA Laser Beam

SELECTION CHART

Model No.	Description
36470	Opto Laser Level with Water Tight Case



INTRODUCTION TO PRESSURE DIFFERENTIAL PRODUCTS

Frequent operation start-ups and environmental temperature swings in mechanical equipment can cause the air pressure inside oil sumps to increase and decrease, causing it to “breathe.” This “breathing” air, in most cases, comes from the external atmosphere through vents, fill ports, seals, and anywhere the oil sump is open to atmosphere. This can cause debris, dirt, and moisture to enter the equipment attacking and breaking down the equipments vital lubricant and ultimately reducing the life of bearings and gears.

The EQUALIZER® Expansion Chamber reduces or eliminates this “breathing” action by replacing the vent, providing an extra 25 cubic inches of airspace, by a rolling diaphragm. This provides the extra air volume necessary to overcome expansion and retracting inside the housing, *eliminating the need for equipment to “breathe” contaminated and damaging external air.* But, just how much of this “breathing” occurs? Below is a typical installation of a common piece of equipment and the effects of temperature fluctuations.

Using the following volume and temperature parameters, these values can be entered into the plug-in worksheet supplied at:

www.tricocorp.com/technical/sizing-expansion-cham.aspx, or follow the **Selection of an Expansion Chamber** worksheet supplied on the following page. As shown here, a relatively common occurrence can produce up to almost 18³ in of air expansion which escapes through the seals or vents. Conversely, that 18³ in needs to return to the housing when temperatures cool. That is when the damage is done.

Closing your system is the most effective way to eliminate harmful contaminants from entering your system and the Equalizer Expansion Chamber supplies the added air volume to eliminate the need for breathing due to temperature fluctuations. This is especially important when used in harsh or contaminated environments and when frequent start-up and shut-downs are necessary.



Amount of Oil in Housing (oz)	Temp. Range of Housing (F)		Total Volume in Housing (oz.)	Total Expansion
	High	Low		
32	110	60	128	17.81 cubic inches

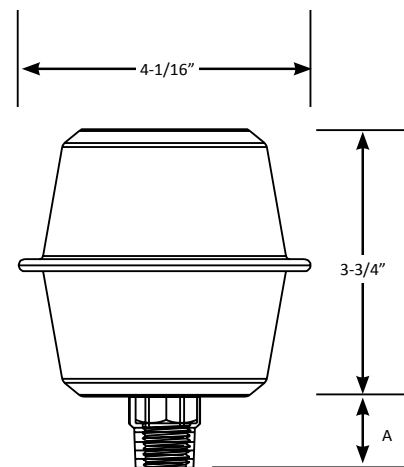
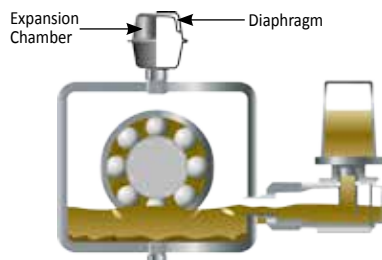
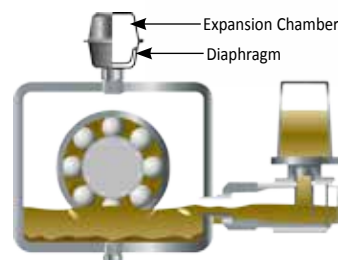


EQUALIZER EXPANSION CHAMBERS

Equalizer Expansion Chambers are designed to prevent pressure increase in closed systems. A rolling diaphragm provides a variable volume, that when properly sized, maintains oil housing pressure at or near zero PSI. The reduced pressure will extend seal life and help prevent leakage. Expansion chambers also protect the integrity of closed systems by preventing the exchange of air from the chamber to the surrounding atmosphere. A choice of thread sizes offers flexibility to the user.

FEATURES

- Made from corrosion resistant stainless steel
- Controlled housing pressure extends seal life
- Prevents contamination ingress to help lubricants stay cleaner for longer life and improved performance
- Full 25 cubic inch air expansion capability
- Maintenance free operation



HELPFUL TIP:

Prevention of oil contamination and degradation is very often the most reliable means of preventing equipment failures. By minimizing the ways that contamination can enter equipment, lubricant cleanliness levels are increased. Products such as the Watchdog Oilers, Opto-Matic Closed System Oilers, Equalizer Expansion Chambers, and Watchdog Breathers, can help lubricants remain cleaner longer.

* For application assistance on calculating required capacities, please contact Trico or visit our web site for an online worksheet at www.tricocorp.com/technical/sizing-expansion-cham.aspx.



SELECTION CHART

Model No.	Connection (NPT)	Capacity	Dim. (A) (in.)
31815	3/8	25 cu. in.	7/8
31816	1/2	25 cu. in.	1
31817	3/4	25 cu. in.	1-1/4

SPECIFICATIONS

Body	Stainless Steel
Diaphragm	Viton®
Max. Operating Temp.	350°F



SELECTION OF AN EXPANSION CHAMBER

DETERMINE TOTAL AIR EXPANSION

To determine the correct expansion chamber size required for your application, obtain the following data and follow the steps listed below. Please visit our website for assistance on calculating required capacities at www.tricocorp.com/technical/sizing-expansion-cham.aspx.

- The amount of oil, in ounces, normally in the bearing housing. _____ oz.
- Multiply above answer by 1.804 to obtain _____ in³ (oil volume).
Place this value into the table below **STEPS A & B** in³ (oil volume).
- The temperature range of the bearing housing. High _____ °F Low _____ °F. Place High & Low temperature in **STEP C**. Subtract the low from the high and place in **STEP A** (high-low temp).
- Complete **STEP A**. Multiply oil volume by temperature difference and coefficient of expansion. (NOTE: .0004 is coefficient of expansion for most turbine oils). Place answer in **STEP D**, in³ (oil expansion).
- The total volume of the bearing housing. Many customers may not know this. Contact your pump manufacturer for this information. _____ oz. (total volume).
- Multiply answer from above by 1.804 to obtain _____ in³ (sump volume). Place this value into the table **STEP B** in³ (sump volume).
- Complete **STEP B**, subtract in³ (oil volume) from in³ (sump volume) to get in³ (air volume) and place answer in both places in **STEP C**, in³ (air volume).
- Follow instructions in **STEP C** to get in³ (air expansion). Place answer into **STEP D** in³ (air expansion).
- Complete **STEP D** by adding to get in³ (total expansion), with this information you can select the correct size expansion chamber for your application.

BEFORE STARTING, OBTAIN THE FOLLOWING DATA:

1 Amount of Oil in Housing (oz.)

2 Temp. Range of Housing (°F)

	High
	Low

3 Total Volume in Housing (oz.)

STEP A	Multiply the volume of oil with the temperature span to get oil expansion. _____ in ³ (oil volume) X _____ °F (high-low temp) X .0004 = _____ in ³ (oil expansion)
STEP B	Subtract the oil volume from the sump volume to get air volume. _____ in ³ (sump volume) — _____ in ³ (oil volume) = _____ in ³ (air volume)
STEP C	Determine the absolute temperature range for air, divide high temp + 460 by low temp +460. Multiply (air volume) with temperature factor. Then subtract the (air volume) to get the air expansion for the maximum change in temperature. _____ in ³ (air volume) X $\frac{(\text{_____ high temp} + 460)}{(\text{_____ low temp} + 460)}$ — _____ in ³ (air volume) = _____ in ³ (air expansion)
STEP D	Add (oil expansion) with (air expansion) to get total expansion. _____ in ³ (oil expansion) + _____ in ³ (air expansion) = _____ in ³ (total expansion)



CLOSED SYSTEM HOT SETUP KIT

Pressure differential between the equipment housing and surrounding atmosphere is a leading cause of moisture ingress. Equipment operation where housing temperature fluctuations occur during frequent on/off running conditions, process fluid temperature changes, outdoor use, and air flow over the equipment create a “breathing” condition as pressure is equalized.

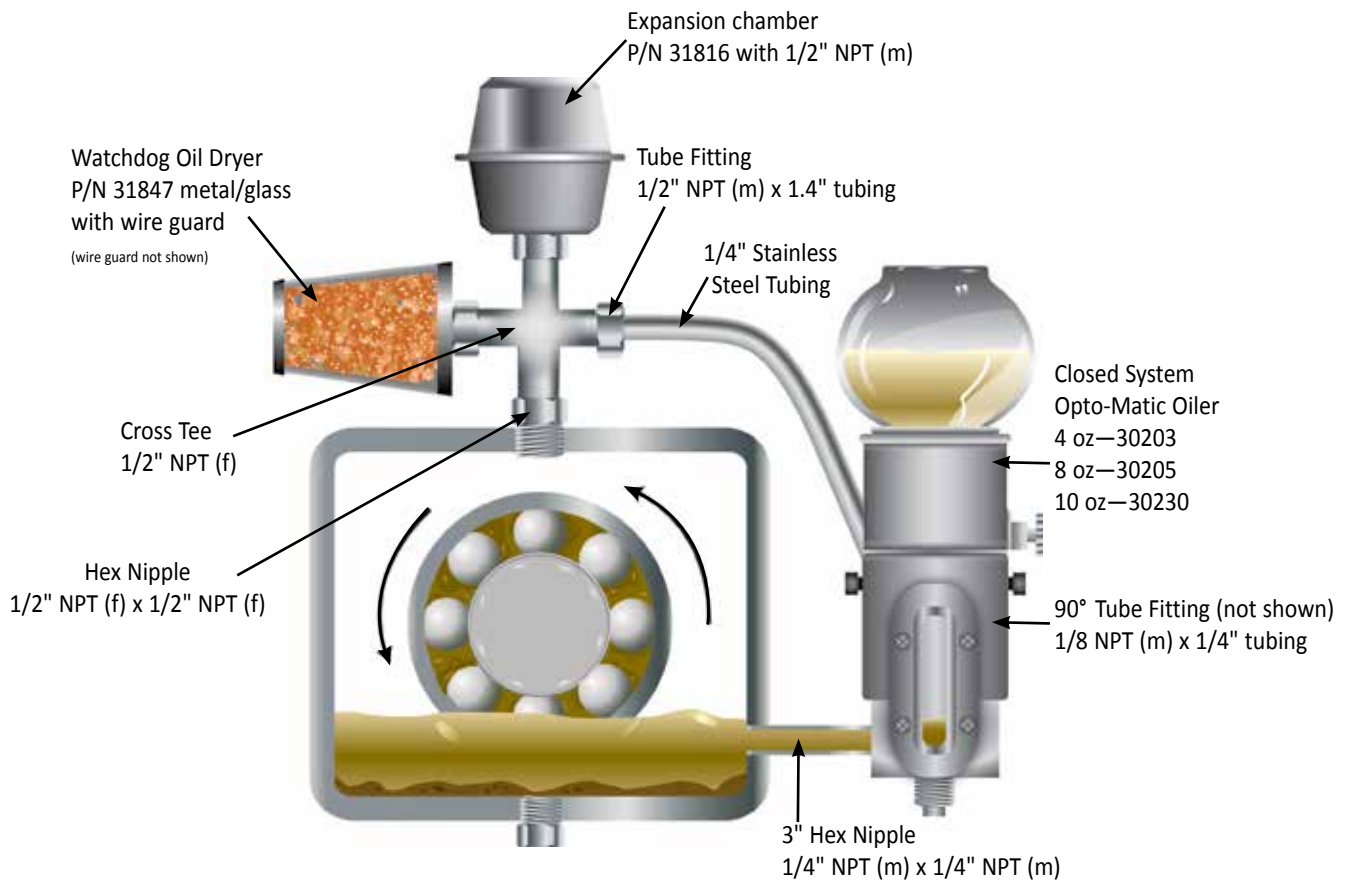
This “breathing” condition allows moisture to be introduced into the equipment causing the oil to absorb it at a variable rate depending on temperature, oil type, and lubricant agitation. The Closed System Hot Setup kit is used to minimize the detrimental effects of equipment “breathing.”

FEATURES

- Includes all necessary fittings and hardware for quick, easy installation
- All fittings are in 316 Stainless Steel for corrosion resistance

SPECIFICATIONS

Model No.	Description
40103	Closed System Hot Setup Kit with 4 oz Closed System Oiler
40105	Closed System Hot Setup Kit with 8 oz Closed System Oiler
40110	Closed System Hot Setup Kit with 16 oz Closed System Oiler



INTRODUCTION TO VISUAL INSPECTION UNITS

Monitoring proper levels and the condition of operating fluids is essential in many industrial applications. Although important, these elements are often overlooked and cause detrimental affects to the life of the fluid as well as, the equipment it supplies. Fortunately, Trico offers products such as, viewports and liquid level gauges, which provide an easy and accurate method for visually inspecting many types of industrial fluids. In addition, Trico also offers sump bottles as a further means for visual inspection. These bottles function as a collection chamber for both sediments and free water that can invade oil sump applications. Using these products in conjunction or separately, can have positive influences on fluid and equipment costs. By taking a proactive approach and installing visual inspection products, the life of your industrial equipment can be significantly prolonged.



Closed system liquid level gauge with pressure balancing line connected to a gearbox housing

SUMP BOTTLES



Trico sump bottles are used as collection chambers on bearing housings and other oil sump applications. They collect water and contaminants, and have a drain plug for easy inspection and removal of fluids.

FEATURES

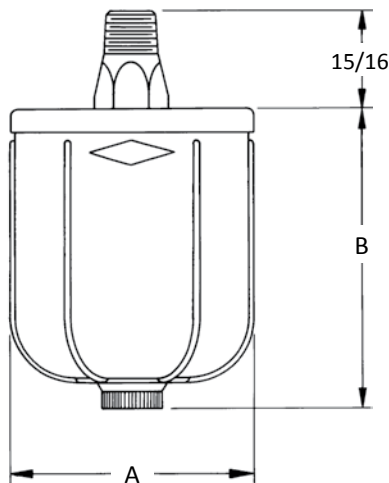
- Easy open/close drain valve
- Plastic reservoirs have reinforcing ribs for long life and impact resistance
- Copper brazing of all steel connections provides long life and leak proof design
- Zinc plating resists corrosion

SPECIFICATIONS

Max. Operating Temp.	165°F Continuous
Reservoir	Butyrate Plastic
Gasket	Buna-N
Materials	Steel and Brass
Finish	Bright Zinc Plated

SELECTION CHART

Model No.	Capacity	Connection (NPT)	Dimensions (in.)	
			A	B
31321	2 oz.	1/8	1-15/16	2-1/16
31341	4 oz.	1/8	2-5/16	2-7/8
31342	4 oz.	1/4	2-5/16	2-7/8
31382	8 oz.	1/4	2-5/8	4



HELPFUL TIP:

Oil should be clear and bright in sump bottles. If water or sediment is observed, remove immediately and investigate source. Up to 70% of equipment fails prematurely due to contamination in lubricants.



LIQUID LEVEL GAUGES



Liquid level gauges provide easy viewing in many industrial applications. They are ideal for bearings, transformers, and many other non-pressure applications.

FEATURES

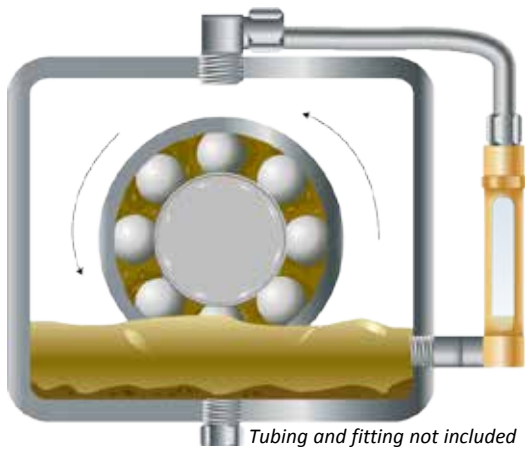
- Guards are standard on all sights and may be rotated 360° for easy viewing
- Glass tubes offer high temperature use to 250°F
- Wide range of mounting styles to fit most applications
- Optional top caps are available

HOW TO ORDER

1. Choose the type of gauge mounting and configuration:
 - BG - Straight Male Thread
 - BE - Short Male Elbow
 - BF - Female Elbow
2. Select model number using selection charts for correct size of gauge.
3. Optional top caps are available. Add the following suffixes to the part number:
 - “C” - A cap with a 1/8 NPT port is provided for use in closed system applications. This is a non-vented design.
 - “F” - A filter is installed in the vent cap to minimize contamination.

SPECIFICATIONS

Construction	Brass
Sight	Glass
Seals	Viton
Max. Operating Temp.	250°F



CLOSED SYSTEM TOP CAPS

For closed system applications, all liquid level gauges can be ordered with a top cap that has a 1/8 NPT port for installing a pressure balancing line to the reservoir. Contamination from water and particulate is reduced and equipment life is prolonged.

To make this conversion, use the selection chart below to order the closed system conversion cap. To order a new liquid level gauge with this cap installed, add the suffix “C” to the part number.

TOP CAP SELECTION CHART

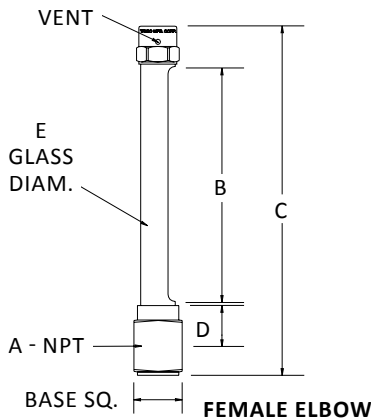
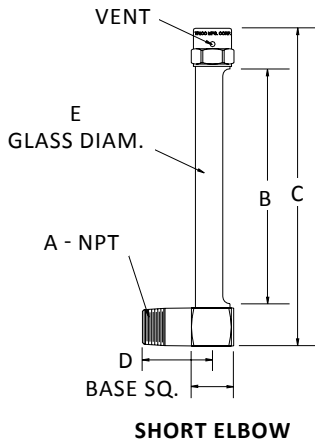
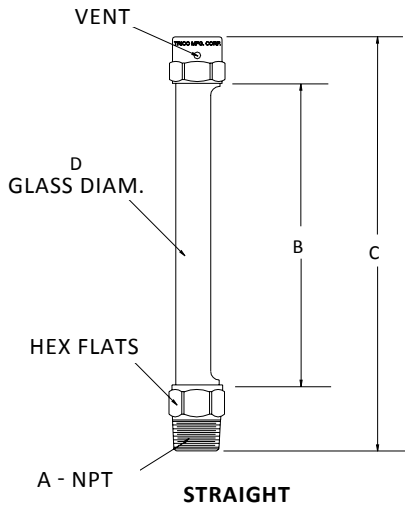
Model No.	Description	Gauge Size	Connection Thread Size
13218	Closed System Conversion Cap	5/8" Glass Diameter	1/8 NPT



13218



LIQUID LEVEL GAUGES



SELECTION CHART—STRAIGHT

Model No.	Dimensions (in.)				
	A	B	C	D	HEX
BG-0150-2	1/4	1-1/2	3-1/4	5/8	13/16
BG-0150-3	3/8	1-1/2	3-1/4	5/8	13/16
BG-0350-2	1/4	3-1/2	5-1/4	5/8	13/16
BG-0350-3	3/8	3-1/2	5-1/4	5/8	13/16
BG-0550-2	1/4	5-1/2	7-1/4	5/8	13/16
BG-0550-3	3/8	5-1/2	7-1/4	5/8	13/16
BG-0550-4	1/2	5-1/2	7-3/8	5/8	7/8
BG-0750-2	1/4	7-1/2	9-1/4	5/8	13/16
BG-0750-3	3/8	7-1/2	9-1/4	5/8	13/16

SELECTION CHART—SHORT ELBOW

Model No.	Dimensions (in.)					
	A	B	C	D	E	Square
BE-0150-2	1/4	1-1/2	3-1/2	1-3/4	5/8	7/8
BE-0150-3	3/8	1-1/2	3-1/2	1-3/4	5/8	7/8
BE-0350-2	1/4	3-1/2	5-1/4	1-3/4	5/8	7/8
BE-0350-3	3/8	3-1/2	5-1/4	1-3/4	5/8	7/8
BE-0550-2	1/4	5-1/2	7-1/4	1-3/4	5/8	7/8
BE-0550-3	3/8	5-1/2	7-1/4	1-3/4	5/8	7/8
BE-0750-2	1/4	7-1/2	9-1/4	1-3/4	5/8	7/8
BE-0750-3	3/8	7-1/2	9-1/4	1-3/4	5/8	7/8

SELECTION CHART—FEMALE ELBOW

Model No.	Dimensions (in.)					
	A	B	C	D	E	Square
BF-0150-3	3/8	1-1/2	3-3/4	9/16	5/8	1
BF-0350-3	3/8	3-1/2	5-3/4	9/16	5/8	1
BF-0550-3	3/8	5-1/2	7-3/4	9/16	5/8	1
BF-0750-3	3/8	7-1/2	9-3/4	9/16	5/8	1



VIEWPORTS



To resist corrosion, these viewports are offered in zinc plated steel. The lenses can be removed in the field for cleaning, rather than purchasing and installing a new viewport. Extended lens design simplifies liquid viewing, especially on small sizes.

FEATURES: 3D PLASTIC

- Extended design simplifies liquid viewing, especially on small sizes
- Straight protruding lens reduces distortion created by domed lenses
- Removable lens allows for cleaning and servicing
- Engineered thermoplastic lens for long life
- Plated steel or brass bodies

SPECIFICATIONS

Body	Zinc Plated Steel/Brass
Window	Polysulfone/Glass
Max. Operating Temp.	300°F (149°C)
Max. Pressure	50 PSI
Seal	Viton

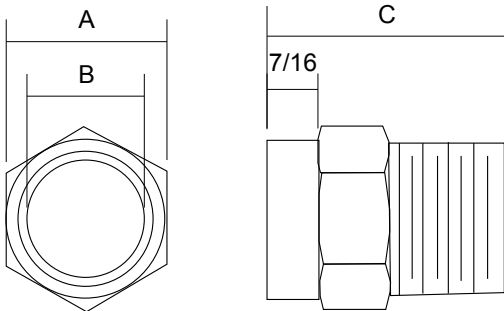
FEATURES: GLASS

- Available with or without baffles
- Removable lens allows for cleaning or servicing
- Plated steel or brass bodies



SELECTION CHART 3D Viewports with Plastic Lens

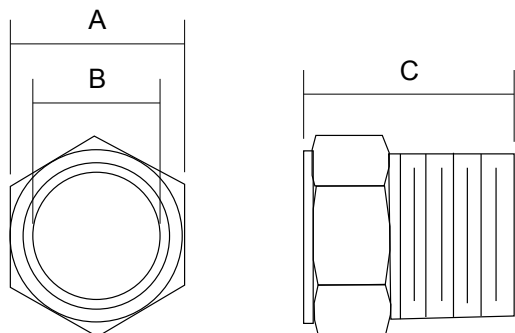
Model No.		Connection	Dimensions		
Steel	Brass		A	B	C
34199	34230	1/2" NPT	7/8	1/2	1-17/32
34201	34231	3/4" NPT	1-1/8	3/4	1-9/16
34202	34232	1" NPT	1-15/16	1	1-11/16



3-D VIEWPORTS WITH PLASTIC LENS

SELECTION CHART Viewports with Glass Lens and Baffle

Model No.		Connection	Dimensions		
Steel	Brass		A	B	C
34305	34341	1/2 NPT	7/8	1/2	1-3/32
34306	34342	3/4 NPT	1-1/8	3/4	1-1/8
34307	34343	1 NPT	1-5/16	1	1-1/4
34308	34344	1-1/4 NPT	1-3/4	1-1/4	1-5/16
34309	34345	1-1/2 NPT	2	1-1/2	1-11/32



VIEWPORTS WITH GLASS LENS

SELECTION CHART Viewports with Glass Lens and without Baffle

Model No.		Connection	Dimensions		
Steel	Brass		A	B	C
34320	34351	1/2 NPT	7/8	1/2	1-3/32
34321	34352	3/4 NPT	1-1/8	3/4	1-1/8
34322	34353	1 NPT	1-5/16	1	1-1/4
34323	34354	1-1/4 NPT	1-3/4	1-1/4	1-5/16
34324	34355	1-1/2 NPT	2	1-1/2	1-11/32



INTRODUCTION TO OIL SAMPLING / ANALYSIS

OIL SAMPLING

Contamination of machinery lubricants is a major problem for many manufacturers. In fact, it has been stated that six to seven percent of the gross national product (\$240 Billion) is required just to repair the damage caused by mechanical wear, which is caused by contamination. However, when contamination is controlled, the life span of a machine's vital components can be extended by as much as 50 times. It's for these reasons and many more that routine sampling is done.



The process of sampling is not only a vital and necessary function in identifying contaminants and contamination levels, but also in understanding the current and future requirements of the equipment and the quality of the lubricant in general. Regularly scheduled oil sampling and analysis programs have become an increasingly important tool for uncovering information necessary to extend the life of your equipment and oil change intervals and minimize maintenance costs associated with oil change outs, labor, repairs and downtime.

Oil sampling technology today is making the process of collecting and analyzing samples much more effective and accurate. Trico offers the latest sampling supplies and accessories, including sample ports and collection devices, which are

designed to extract system and component specific samples that are both representative and repeatable from the best diagnostic locations in the most effective ways possible.

OIL ANALYSIS

Understanding the concept of oil sampling and the benefits involved is an important part of total lubrication management, however, reaping the benefits may require much more. Often, it requires an intimate knowledge of the equipment, its internal design, the system design, the present operating and environmental conditions, the ability to regularly test samples in a safe and contaminant-free environment and recommend and implement corrective actions as needed.



With these challenges in mind, Trico now offers services to inspect, analyze, and report on the operating conditions of entire manufacturing facilities' machinery. Trico offers technical assistance to improve, repair and/or modify equipment and lubrication procedures to meet performance goals and offers on-site or in-house training on best-in-practice ways of implementing lubricant screening regimens, equipment and plant assessments and lubrication management programs.

These services include:

- **Training** - Internationally-recognized courses on Lubrication Management and Oil Analysis can bring equipment maintenance best practices up to speed.
- **Assessments** - Assessments are a critical step in improving the overall lubrication program within a plant. Trico assesses and rates your current program compared to industry "Best Practices". We then provide a detailed report summarizing opportunities for improvement in key areas versus current efforts and conditions.
- **Audits** - An audit is performed to obtain information about the specified equipment including the internal design, the system design, the present operation and environmental conditions. Trico will gather the necessary information and outline recommended equipment lubrication requirements.
- **Consulting** - Trico's specialists in Lubrication and PdM program implementation, documentation integration, and root cause analysis provide practical solutions in the interest of extending asset reliability and helping people operate more proactively.
- **Oil Analysis** - Trico is a leading provider in predictive condition monitoring. Oil samples are taken and analyzed as a preventative maintenance tool and/or diagnostic means to determine cause of equipment failure. Oil is tested for a variety of critical factors including water, particulate, and wear material.



OIL SAMPLING PORTS

Where and how oil samples are collected are two of the most important functions of the oil sampling process. Without a representative sample, further oil analysis efforts will be ineffective. That's why Trico sample ports are designed to draw samples from the most representative areas from industrial equipment. Trico sample ports are also designed to collect samples under the equipment's typical operating condition—another important factor.

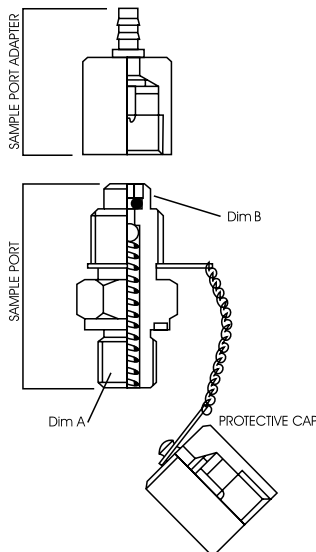
The collection process is a simple, fast and accurate way of sampling hydraulic, lubricating, and circulating systems. Access to systems is done through the use of a mating sample port adapter. The sample port adapter screws onto the sample port. Oil samples can then be drawn from the system and placed into a clean sampling bottle for analysis.

To guard against contaminating the sample and for superior leak protection, Trico sampling ports all feature a check valve and a viton o-ring seal cap.

Trico sample ports are available in several types and sizes to match the varying requirements of manufacturers. Please see below for a complete listing and specifications. To complement the sample ports, there are a number of sample port adapters available, as well.

SPECIFICATIONS

Max. Working Pressure	9000 PSI (630 bar)
Connect Under Pressure	5800 PSI (400 bar)
Check Valve Ball	Chrome Steel
O-Ring	Viton®
Max. Operating Temp.	-4°F to 392°F



FEATURES

- Protective cap seals against dirt and moisture
- Cap connected to sample port with a heavy brass chain to prevent loss
- Sample directly from lubricating oil while equipment is running
- Minimizes introduction of contamination into system
- Used in conjunction with proper accessories sample ports are adaptable to pressure, static, and vacuum locations

SAMPLE PORTS

Carbon Steel	Stainless Steel	Port Connection (Dim A)	Dim B
36100	36102	1/8" NPT	M16x2
36101	36103	1/4" NPT	M16x2

Note: BSPT, BSPP, and O-ring boss threads are available upon request, please contact Trico's Customer Service.



PORT ADAPTERS

Model No.	Port Connection (Dim C)	Dim D	Material
36109	Barb for 1/4" OD Tube	M16x2	Plated Steel
36133	Barb for 1/4" OD Tube	M16x2	Plated Steel



HELPFUL TIP:

Color of cap on port adapter must be the same as sample port, liquid level gauge pitot tubes, and pitot tube to extract a sample (ie. gold to gold, black to black).



PITOT TUBE SAMPLING PORTS

Trico's Pitot Tube sampling ports are designed to provide a safe, simple and effective method of sampling fluids from sumps and non-flooded horizontal drain lines. They ensure oil samples are drawn from the most appropriate location of the sump reservoir, and that the sample is taken from the exact location inside the system each time, which is important for maintaining consistency in routine sampling. The thick wall tubing can be bent and directed to the ideal sampling location with the use of a swivel adapter.

FEATURES

- Pitot Tubes are equipped with sample ports
- Available in a variety of lengths
- Installs easily into drain, fill or sampling pipe ports
- Swivel options available for bent tubes in confined locations

CARBON STEEL SAMPLE PORT AND STAINLESS STEEL TUBE

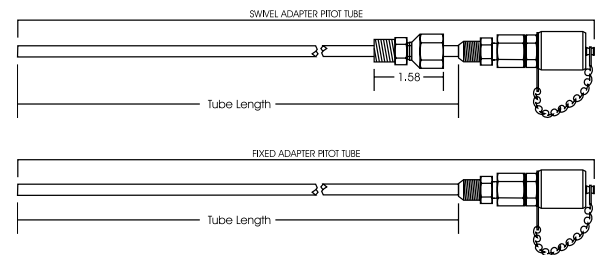
Fixed Adapter	Swivel Adapter	Tube Length	Fitting
36204	36217	12"	1/4" NPT Male
36207	36220	18"	1/4" NPT Male
36210	36223	24"	1/4" NPT Male

STAINLESS STEEL SAMPLE PORT AND TUBE

Fixed Adapter	Swivel Adapter	Tube Length	Fitting
36206	36219	12"	1/4" NPT Male
36209	36222	18"	1/4" NPT Male
36212	36225	24"	1/4" NPT Male

SPECIFICATIONS

Max. Pressure	500 PSI (34.5 bar)
Material	Carbon Steel or Stainless Steel
Check Valve Ball	Stainless Steel
Seal	Viton®
Max. Operating Temp.	-4°F to 392°F



HELPFUL TIP:

Color of cap on port adapter must be the same as pitot tube to extract a sample (ie. gold to gold, black to black).



LIQUID LEVEL GAUGE SAMPLE PORTS

Liquid Level Gauge Sample Ports provide easy viewing of fluid levels and oil condition in many industrial applications. They are ideal for bearing housings and other non-pressurized applications. Liquid Level Gauge Sample Ports include a Pitot Tube for static sampling, which provides repetitive, representative oil sampling.

FEATURES

- Guards are standard on all sights and may be rotated 360° for easy viewing of fluid level and condition
- Liquid Level Gauge Sample Ports are equipped with Pitot Tubes in lengths of 12", 18", and 24"
- Level gauge sights are available in various lengths
- For use with non-pressurized systems

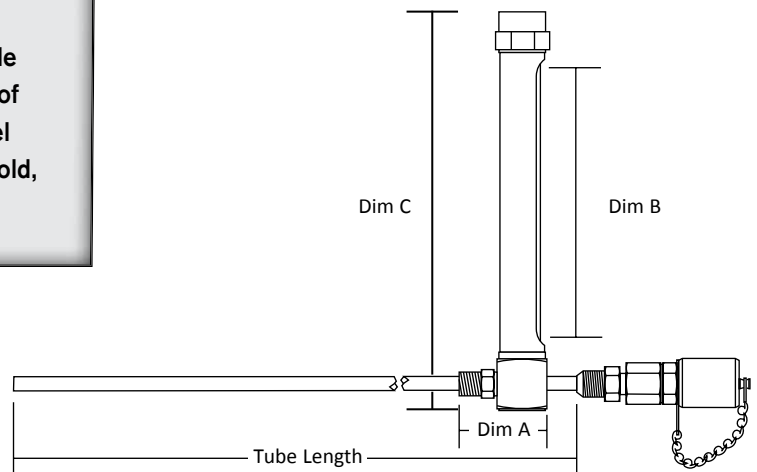


HELPFUL TIP:

A sample port adapter must be used to draw a sample from Trico's Liquid Level Gauge Sample Ports. Color of cap on port adapter must be the same as Liquid Level Gauge Sample Port to extract a sample (ie. gold to gold, black to black).

SPECIFICATIONS

Material (Level Gauge)	Brass
Material (Pitot Tube)	Stainless Steel
Sight	Glass
Seals	Viton®
Max. Operating Temp.	250°F



SELECTION CHART

Pitot Tube Length			Dim A	Sight Length Dim B	Dim C	NPT Male Fitting
12"	18"	24"				
36441	36442	36443	2.00"	3-1/2"	5-1/4"	1/4"
36307	36329	36351	2.18"	5-1/2"	7-1/4"	1/4"
36308	36330	36352	2.18"	7-1/2"	9-1/4"	1/4"
36444	36445	36446	2.00"	3-1/2"	5-1/4"	3/8"
36373	36395	36417	2.00"	5-1/2"	7-1/4"	3/8"
36374	36396	36418	2.00"	7-1/2"	9-1/4"	3/8"

*Stainless steel units are available upon request, please contact Trico's Customer Service.



VACUUM PUMP AND SAMPLING ACCESSORIES

A necessary tool for extracting an oil sample from the sample port, Trico's Vacuum Pump is compact for ease of transport. When used in combination with a sample port adapter, flexible tubing, and a 4-ounce sterilized sample bottle the user is able to connect to any sample port for contamination free oil sampling in the most representative locations.

Trico also offers a heavy-duty Vacuum Pump model that includes a release valve.

FEATURES

- Draws a vacuum of 27 inches of Hg (Mercury)
- Uses 3/16" to 5/16" tubing
- 38-400 bottle thread

VACUUM PUMPS

Model No.	Description
36800	Vacuum Pump, Standard
36801	Vacuum Pump, Heavy-Duty with Release Valve

Note: Bottles sold separately. Please use oil sampling bottles 36813 and 36814 with vacuum pumps.

OIL SAMPLING BOTTLES

Model No.	Description
36812	4 oz Sample Bottle for Black Plastic Mailer
36813	4 oz Sample Bottle, Single
36814	4 oz Sample Bottle, Case of 500
36815	8 oz Sample Bottle
36819	16 oz Oil Sample Purge Bottle
36821	Black Plastic Mailer for 4 oz Bottles

TUBING

Model No.	Description
36806	1/4" OD Poly Tubing, 100 ft Roll
36807	5/16" OD Poly Tubing, 100 ft Roll
36808	1/2" OD Poly Tubing, 100 ft Roll
36809	1/4" OD Poly Tubing, 500 ft Roll
36810	5/16" OD Poly Tubing, 500 ft Roll
36811	1/2" OD Poly Tubing, 500 ft Roll
66216*	1/4" OD Poly Tubing, per foot

*Please specify number of feet when ordering.



HELPFUL TIP:

Prior to sending oil sample to lab, mark clearly on bottle make and model of equipment, brand, type, and weight of oil and any other necessary details to ensure correct analysis when results are returned from the lab.



RESERVOIR BREATHER KITS

Because airborne contaminants can quickly disrupt and negate your sample, Trico offers specially designed Breather Kits. These kits feature a two-stage breather system that utilizes a filter to block airborne particles and desiccant to remove harmful, unwanted moisture. The system ensures a permanent closure on all hydraulic reservoirs and makes sure the lubricating fluid remains closed off from airborne contamination throughout the sampling process.

An optional filter reminder vacuum gauge can be used to indicate when the filter element on the breather has become clogged.

A male quick connect can be plumbed to the 6-bolt adapter plate (this plate replaces the standard filler/breather cap) to fit a down pipe for filling reservoirs with new oil through a filter cart without opening the system to the environment.

For static sampling of oil from the system reservoir, the 6-bolt adapter plate can incorporate a sample port connected to a sample tube. The tube conveniently extends to the middle of the fluid level in the system reservoir to allow samples to be taken from the exact location inside the system every time.

FEATURES

- Optional filter reminder indicates remaining life of filter element
- Color coded desiccant changes colors indicating replacement is needed, when maximum adsorption is reached
- Optional sample port is available with sampling drop tubes of 12", 18", and 24" in length



SPECIFICATIONS DESICCANT BREATHERS

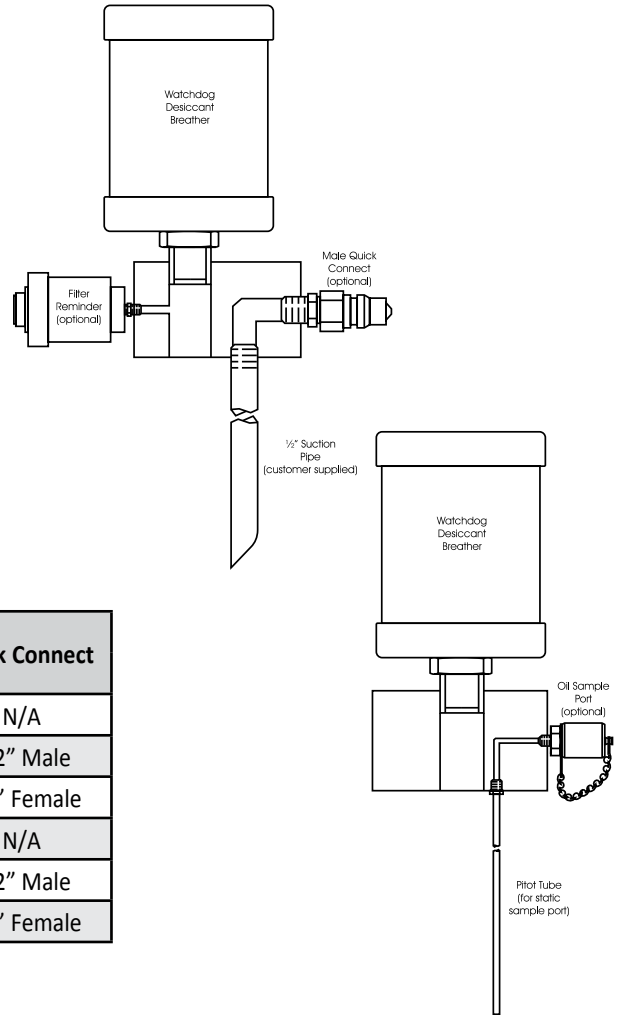
Breather Size	Filter	Desiccant	Silica Gel Volume	Water Capacity (lbs)	Air Flow	Desiccant Replaceable
39102	2 microns	Gold to dark green	2.31 lb	0.9	35 CFM (260 gpm of fluid volume exchange)	No

Note: Trico Watchdog and Watchdog EX Series Breathers can be readily used with the Reservoir Breather Kits, please contact Trico for additional information.

RESERVOIR BREATHER KITS

6 BOLT ADAPTER PLATE WITHOUT SAMPLE PORT

Model No.	Breather Size	Filter Reminder	Quick Connect
36902	39102	No	N/A
36903	39102	No	1/2" Male
36904	39102	No	1/2" Female
36914	39102	Yes	N/A
36915	39102	Yes	1/2" Male
36916	39102	Yes	1/2" Female



6 BOLT ADAPTER PLATE WITH SAMPLE PORT

Tube Length			Breather Size	Filter Reminder	Quick Connect
12"	18"	24"			
36905	36908	36911	39102	No	N/A
36906	36909	36912	39102	No	1/2" Male
36907	36910	36913	39102	No	1/2" Female
36917	36920	36923	39102	Yes	N/A
36918	36921	36924	39102	Yes	1/2" Male
36919	36922	36925	39102	Yes	1/2" Female

FILTER REMINDER

The filter reminder indicates the service life of the filter element. The indicator allows the filter to be changed when needed, thus avoiding unnecessary labor and premature servicing. When filter reminder indicates the need for the filter element to be replaced, just push in the manual reset button when a new filter element is installed.



Normal, clean filter



Indicator shows filter is clogged and needs replacing.

HELPFUL TIP:

Trico Watchdog® and Watchdog EX Breathers can be readily used with the Reservoir Breather Kits. Please call Trico for additional information.



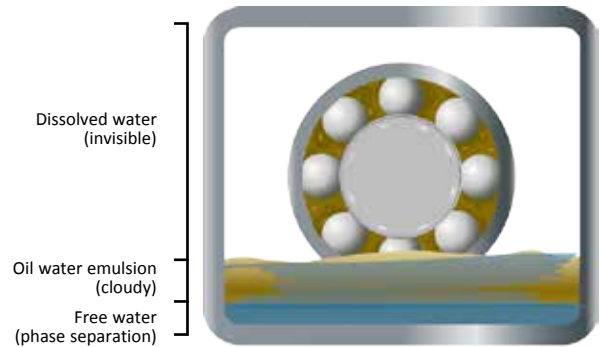
INTRODUCTION TO MOISTURE REMOVAL SYSTEMS

Moisture in lubricating oils is the root cause of prematurely damaging oil and accelerating wear of machine components. As water invades your fluids it will not only attack the additives in the oils, destroying their beneficial properties; but it will also cause damage to the machine surfaces through corrosion, and rapidly degrade the oil through increased oxidation. By understanding the effects of water contamination, it is easy to see the importance of moisture detection and removal.

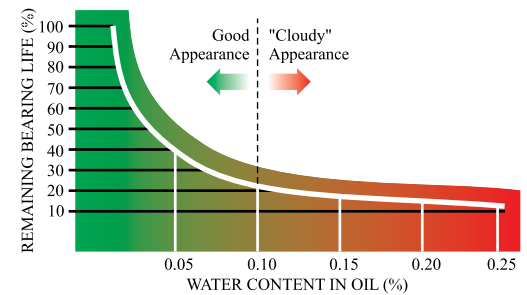
Once water has entered the lubricant, it can exist in one or more of the following forms; dissolved, emulsified, or free water.

- **Dissolved water** contains water molecules that are dispersed one-by-one through the air in contact with, or within the lubricant. This form of water is invisible to the naked eye.
- **Emulsified water** contains microscopic pockets of water that are dispersed in stable suspension in the oil. As the oil ages this area of water will expand, causing the lubricant to look cloudy.
- **Free water** is the phase separation of emulsified water. Free water when mixed with the lubricant readily settles to the bottom of the equipment.

The most damaging forms of water contamination, to both the lubricant and equipment, are emulsified and free water. Therefore, it is important to measure, and/or remove water contamination prior to the formation of emulsified and free water.



Three stages of water within a lubricating oil



By the time free water becomes visible, damage is already occurring to the oil and equipment.

REMOVING WATER CONTAMINATION

A proven method of removing water contamination from lubricating fluids is using silica gel technology. Silica gel extracts water vapor from the air as it is drawn through a silica gel bed, as well as covering a wide range of temperatures. Most units using silica gel technology to remove moisture provide a fail-proof method of determining when replacement is necessary. Trico incorporates a visual indicator to accomplish this. The silica gel used changes from gold to dark green when maximum adsorption has been reached.

Trico provides products that will remove moisture from lubricating oils; however the root cause of moisture contamination should be identified and corrected to maximize the life of the lubricant and equipment.



Watchdog Breather installed on a hydraulic reservoir



Watchdog Breather installed on a gearbox at a water treatment facility



WATCHDOG® DESICCANT BREATHERS



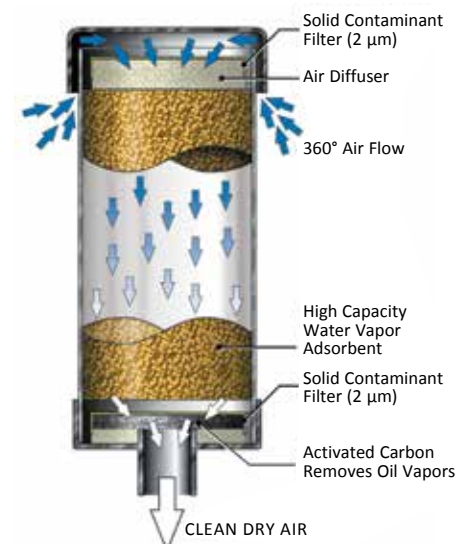
Watchdog Desiccant Breathers ensure optimum protection of industrial equipment by prohibiting the entry of moisture and particulate contamination. Contaminants enter industrial equipment as pressure differentials or fluid level changes occur. The Watchdog Breathers are ideal for circulating oil systems, oil sumps, process tanks, storage tanks, vacuum systems, hydraulic systems, transformer cases, or anywhere that equipment needs to be dry and clean.

Watchdog Desiccant Breathers perform two very important functions.

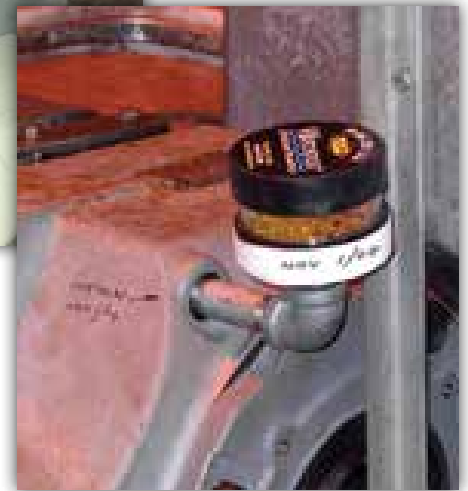
1. They adsorb unwanted moisture inside industrial equipment using silica gel technology. Unwanted moisture can lead to corrosion, shortened fluid life, and additive depletion.
2. They collect airborne solid particles by means of a dual, anti-static filter system. This reduces the amount of abrasive and damaging contaminants that create sludge build-up inside the fluid reservoir.

FEATURES

- **Bi-directional air flow** - A 360° air flow allows air to be breathed in and out as fluid level changes or differential pressures occur.
- **Dual filtration system** - A two micron filter is located at the top and bottom of the silica gel bed. The top filter removes particle contamination from atmospheric air and the bottom helps with dust created by the silica gel beads contacting each other.
- **Water vapor adsorbent** - The silica gel used in the Watchdog Desiccant Breathers adsorb up to 40% of its own weight.
- **Durable construction** - Watchdog Desiccant Breathers are manufactured from rugged ABS plastic and impact modified acrylic.
- **Color indicator** - When maximum adsorption is reached the silica gel turns from gold to dark green, indicating replacement is needed.
- **Activated carbon** - As air is expelled, it passes through activated carbon which removes oil vapors, fumes, and odors (except for 39131, 39132, 39133, and 39134).



WATCHDOG® DESICCANT BREATHERS



SPECIFICATIONS

Material	ABS plastic and impact modified acrylic
Max. Operating Temp.	-20°F to 200°F (-28°C to 93°C)

SELECTION CHART

(Desiccant Breathers)

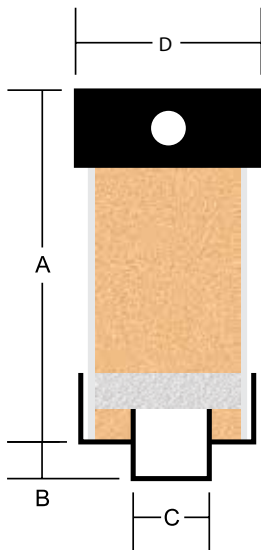
Model No.	Height (in.)	Diameter (in.)	Connection Size	Silica Gel Volume	Water Capacity (fl oz)	Air Flow
39100	3.5	5	1" Male Friction Fit	0.8 lb.	4.91	20 CFM (150 gpm of fluid volume exchange)
39101	5	5	1" Male Friction Fit	1.4 lb.	8.6	
39102	8	5	1" Male Friction Fit	2.7 lb.	16.56	
39103	8	5	1" Male NPT	2.7 lb.	16.56	
39108	10	5	2" Male NPT	3.5 lb.	21.47	
39131	2	2	1/2" Female NPT	.08 lb.	.49	5 CFM (37 gpm of fluid volume exchange)
39132	3.25	2	1/2" Female NPT	.1 lb.	.92	
39133	2	3.25	1/2" Female NPT	.3 lb.	1.84	
39134	3.25	3.25	1/2" Female NPT	.5 lb.	3.06	

ACCESSORIES

Adapters are ordered separately, please see Watchdog Breather Adapters page F6.

WATCHDOG® EX SERIES BREATHERS

In certain extreme operating environments such as a paper mill or in food processing where regular steam cleaning occurs, the humidity level far exceeds normal industrial environments. In these situations, lubricants and other fluids stored in tanks and reservoirs need the protection of a desiccant breather even more. However, small temperature variations draw in the humid air and unnecessarily reduce the life of the breather. The Watchdog EX Series Breathers for extreme humidity applications incorporate two check valves, one to control airflow into the protected reservoir and one to control airflow out. This prolongs the life of the desiccant by allowing the air to flow through the breather only when needed to protect the integrity of the tank. Unlike a membrane system, which does not allow internally generated gases and contaminants to exit the system, the Watchdog EX Breather offers all of the advantages of breathing air in and out of the tank while removing water vapor and solid particles before they contaminate the fluid.



The reusable top cap contains the inlet and outlet valves which protect the silica gel from excess humidity.

The reusable top cap with inlet and outlet valves allows the economic replacement of the desiccant cartridge.



SPECIFICATIONS

Operating Temp. Range	-20°F to 200°F (-28°C to 93°C)
Material	ABS plastic and impact-modified acrylic
Particulate Filtration Level	2 Micron Filter
Check Valve Capacity	.3 psi in/2.1 psi out (except for P/N 39110: .3 psi in/.3 psi out)

FEATURES

- **Water Vapor Adsorbent** - longer lasting desiccant formulated specifically for maximum efficiency at humidity levels of 80% and higher
- **Color Indicating** - When maximum adsorption is reached the silica gel turns from gold to dark green, indicating replacement is needed. The silica gel used is chemically inert, non-corrosive, and does not contain cobalt chloride, a heavy metal. The color changing dye used is environmentally safe and meets all health and safety requirements.
- **Durable Construction** - Watchdog Ex Breathers are manufactured from rugged ABS plastic and impact modified acrylic
- **Easy Connection** - Models are available with 1" slip fit connection which mates with the standard Watchdog Breather adapters or with a 2" male NPT connection
- **Reusable Top Cap** - Allows the economic replacement of the desiccant cartridge

SELECTION CHART

Model No.	Dim A	Dim B	Dim C	Dim D	Rate Airflow	Water Capacity	Replacement Cartridge Number
39110	6.25 in.	N/A	1/2" FNPT	3.25 in.	10 CFM	4.91 fl oz	39217
39111	5 in.	1.25 in.	1" slip	5 in.	20 CFM	8.6 fl oz	39218
39112	8 in.	1.25 in.	1" slip	5 in.	20 CFM	16.56 fl oz	39219
39113	5 in.	1.87 in.	2" MNPT	5 in.	20 CFM	8.6 fl oz	39310
39114	8 in.	1.87 in.	2" MNPT	5 in.	20 CFM	16.56 fl oz	39222

ACCESSORIES

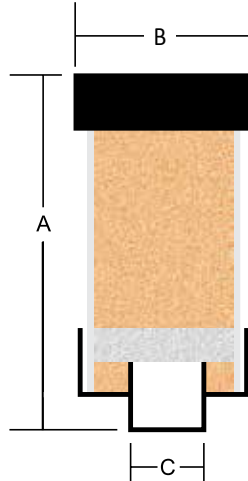
Adapters are ordered separately, please see Watchdog Breather Adapters page F6.



WATCHDOG® R SERIES BREATHERS

The Watchdog R Series Breathers are designed for applications where gearboxes and reservoirs are subjected to continuous vibration such as railroad maintenance equipment, off-road vehicles, mining equipment, and others. The units are easily attached to the equipment by rugged steel pipe threads.

When the silica gel cartridge turns from gold to dark green, simply install a new replacement cartridge to the reinforced metal base.



A replacement cartridge is easily threaded into the metal reinforced base.

FEATURES

- **Water Vapor Adsorbent** - longer lasting desiccant formulated specifically for maximum efficiency at humidity levels of 80% and higher.
- **Color Indicating** - When maximum adsorption is reached the silica gel turns from gold to dark green, indicating replacement is needed. The silica gel used is chemically inert, non-corrosive, and does not contain cobalt chloride, a heavy metal. The color changing dye used is environmentally safe and meets all health and safety requirements.
- **Durable Construction** - Watchdog R Breathers are manufactured from rugged ABS plastic, impact modified acrylic, and metal base.
- **Easy Connection** - Models are available with 1" and 2" rugged steel male pipe threads.
- **Reusable Bottom Cap** - Allows the economic replacement of the desiccant cartridge.

SELECTION CHART

Model No	Dim A	Dim B	Dim C	Adsorption Capacity	Airflow	Replacement Cartridge Number
39150	5 in	5.2 in	1" MNPT	4.91 fl oz	25 CFM	39160
39151	6.5 in	5.2 in	1" MNPT	8.6 fl oz	25 CFM	39161
39152	9.5 in	5.2 in	1" MNPT	16.56 fl oz	25 CFM	39162
39153	6 in	5.2 in	1.125" female thread	8.6 fl oz	25 CFM	39161
39154	6.5 in	5.2 in	2" MNPT	8.6 fl oz	25 CFM	39161
39155	9.5 in	5.2 in	2" MNPT	16.56 fl oz	25 CFM	39162
39156	12 in	5.2 in	2" MNPT	21.47 fl oz	25 CFM	39166

SPECIFICATIONS

Operating Temp. Range	-20°F to 200°F (-20°C to 93°C)
Particulate Filtration Level	2 micron
Material	ABS plastic and steel threads

ACCESSORIES

Adapters are ordered separately, please see Watchdog Breather Adapters page F6.



WATCHDOG® BREATHER ADAPTERS

ADAPTER SELECTION

Watchdog Desiccant Breathers are easily installed using one of several adapters designed for different applications.



ADAPTER SELECTION CHART

(part numbers with male friction slip fitting)

Model No.	Description
39200	Flange adapter, without mounting holes
39201	Flange adapter, with 6 ANSI mounting holes
39202	Threaded adapter, 1" NPT male x 1" slip fit
39203	Threaded adapter, 3/4" NPT male x 1" slip fit
39204	Bayonet adapter
39205	Spin-on adapter, 1"-12 UNF female x 1" slip fit
39206	Spin-on adapter, 1-1/2"-16 UNF female x 1" slip fit
39207	Bypass adapter
39216	Adapter, 1/2" NPT male x 1" slip fit

ADAPTER SELECTION CHART

(part numbers 39131, 39132, 39133 and 39134)

Illustration	Model No.	T1	T2
	39208	1/2" NPT	1/4" NPT
	39210	1/2" NPT	3/8" NPT
	39212	1/2" NPT	1/2" NPT
	39213	1/2" NPT	3/4" NPT
	39215	1/2" NPT	1" NPT
	39209	1/4" NPT	1/2" NPT
	39211	3/8" NPT	1/2" NPT
	39214	3/4" NPT	1/2" NPT



Bypass Adapter
(P/N 39207)

THE BYPASS ADAPTER

The Bypass Adapter is designed for applications where there is very heavy oil mist being expelled from the equipment.

When air is breathed into the equipment, it passes through the Watchdog® and is cleaned and dried. When the air is breathed out of the equipment it enters the adapter and is expelled to the outside without passing back through the breather. This protects the breather from oil contamination.

WATCHDOG® OIL DRYER

The Watchdog Oil Dryer is a non-vented system designed to remove water vapor from the air as it is drawn through a bed of silica gel. It is ideal for bearing housings and other applications where moisture condensation must be minimized.

The compact design and standard thread size are designed to simplify installation. Equipment can be protected from internal moisture damage when the Watchdog Oil Dryer is installed.

FEATURES

- Desiccant cartridges change color to indicate when replacement is required
- Cartridge replacement is simple and takes less than on
- Multi-purpose—serves as a viewport, a fillport and an oil dryer

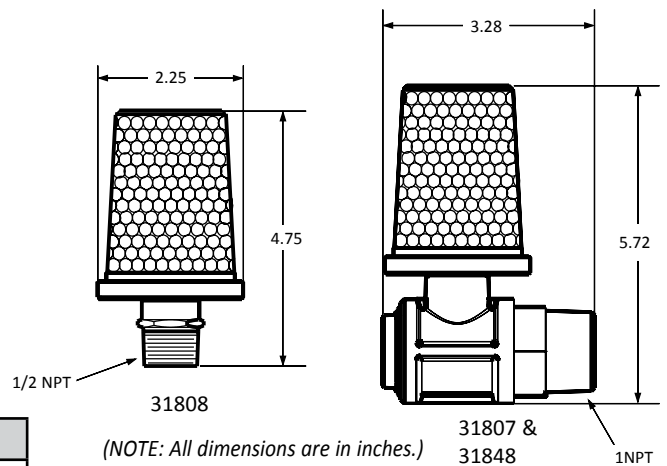


SELECTION CHART

Model No.	Description
31807	1" NPT Polysulfone Oil Dryer with viewport
31808	1/2" NPT Polysulfone Oil Dryer without viewport
31847	1/2" Metal/Glass Oil Dryer with viewport and guard
31848	1" NPT Metal/Glass Oil Dryer with viewport
31849	1" Metal/Glass Oil Dryer with viewport & wire guard

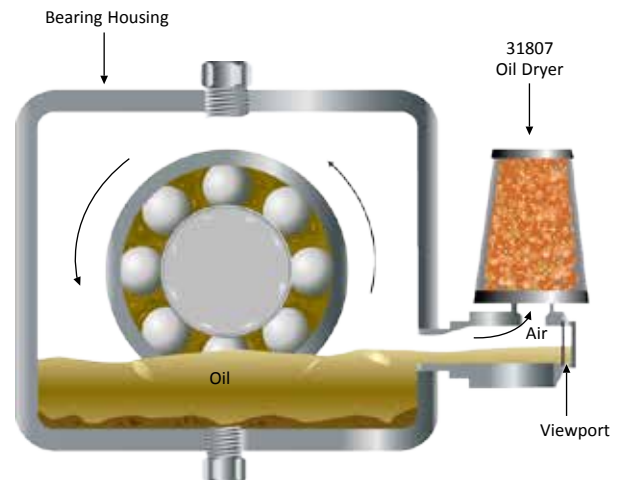
SPECIFICATIONS

Connections	31807	31808	31848 & 31849
Material	Polysulfone	Polysulfone	Glass & Aluminum
Max. Operating Temp.	325°F/160°C	325°F/160°C	325°F/ 160° C

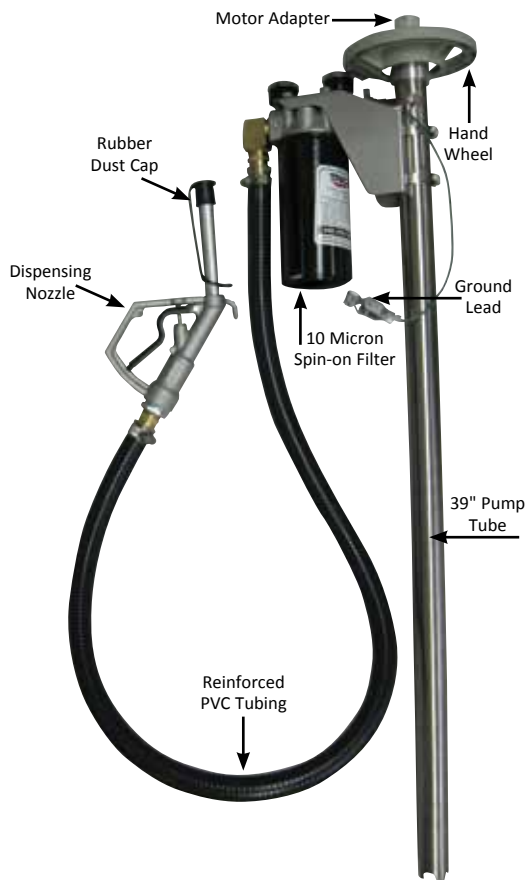


REPLACEMENTS

Model No.	Description
21841R	Replacement cartridge for model number 31807
31854	1 gal refill of desiccant



DRUM PUMP FILTRATION SYSTEM



Drum Pump Filtration System—P/N 30017

Actively filtering lubricants from storage drums can prevent contamination related problems. Trico's Drum Pump Filtration System can prevent contamination or remove it when used in daily operations, including filtering oil directly from the storage drum to fill totes and transfer containers.

The Drum Pump Filtration System provides a dispensing nozzle for continuous flow and metering of lubricants, and a protective rubber nozzle cap to prevent contaminants from entering the nozzle when not in use. This system is capable of delivering a flow up to 6.8 gpm and is rated for use with lubricants up to a viscosity of 7,000 SUS, depending on motor selection. The Drum Pump Filtration System comes standard with a 10 micron absolute Beta>200 spin-on filter element and a sealing bung adapter. Differential pressure gauges help specify the filter element condition and the need for replacement.

The universal design of the Drum Pump Filtration System integrates a quick change hand wheel design, allowing the motor to be transferred from one Drum Pump Filtration System to another without buying additional motors or removing the entire apparatus. This follows industries best handling practices by avoiding cross contamination of different lubricant types, reduces further particle contamination and eliminates messy lubricant spills.

SELECTION CHART

Model No.	Description
30017	Drum Pump Filtration System
30018	Electric Pump Motor - 120V/60 Hz
30019	Pneumatic Pump Motor
30021	Electric Pump Motor - 220V/50 Hz



Electric Pump Motor –
P/N 30018 or 30021



Pneumatic Pump Motor –
P/N 30019

FEATURES

- Hand wheel modular design for easy transfer of motor to other Drum Pump Filtration Systems
- Clear, non-collapsible PVC for visual confirmation of flow
- Differential filter gauges to indicate filter element condition and replacement
- Dispensing nozzle offers a controlled solution for safe lubricant transfer



DRUM PUMP FILTRATION SYSTEM

SPECIFICATIONS—DRUM PUMP FILTRATION SYSTEM (P/N-30017)

Type	Seal-less / Centrifugal
Material	Stainless Steel 316
Tube Length	39"
Max. Temp.	190°F (90°C)
Discharge Nozzle	3/4"
Discharge Line	1" Non-Collapsible PVC
Filter Media	10 Micron Absolute Beta>200
Replace Filter Media @	20 PSI Differential

SPECIFICATIONS—ELECTRIC PUMP MOTOR

	30018	30021
Electric Motor	1.10 HP @ 10,000 RPM	
Max. Viscosity	7,000 SUS	
Electric Motor Rating	110V, 50-60 Hz, 8.5 A	220V/50Hz
Flow Rate	6.8 GPM	

SPECIFICATIONS—PNEUMATIC PUMP MOTOR (P/N-30019)

Pneumatic Motor	3/4 HP @ 8,000 RPM
Maximum Viscosity	3,500 SUS
Inlet Pressure	100 psi max @ 28 CFM
Stall Pressure	50 psi
Flow Rate	4.5 GPM

FILTER MEDIA

	36976	36977	36978
Micron Rating	3	10	10
Filter Type	Particulate	Particulate	Water
Media Type	Synthetic Micro-Glass	Synthetic Micro-Glass	—
Diameter	3.7"	3.7"	3.7"
Length	8"	8"	8"
Thread	3/4-16 UN-2B	3/4-16 UN-2B	3/4-16 UN-2B
Beta Ratio	Beta 3 ≥ 200 Absolute	Beta 10 ≥ 200 Absolute	10 micron nominal
Dirt Holding Capacity	41 grams	48 grams	N/A
Water Holding Capacity	N/A	N/A	8 oz*

*Based on flow rate and viscosity



Pneumatic Pump Motor installed on Drum Pump Filtration System



Electric Pump Motor installed on Drum Pump Filtration System

HIGH-VISCOSITY GEAR & LUBE OIL FILTRATION SYSTEM



In the past choices were very limited when it came to filtering lubricants with viscosities greater than 500 SUS @ 100°F. Now Trico offers a solution with our High-Viscosity Gear and Lube Oil Filtration System. The problem with attempting to filter a high viscosity oil with a lower viscosity system is that the pump and filters are not designed to work with higher pressures required to push high viscosity fluids through the system. As a result these low viscosity units operate primarily in “bypass” mode where little if any of the high-viscosity oil gets filtered.

That is where Trico’s High-Viscosity Gear and Lube Oil Filtration Systems comes in. These systems are specifically designed for high-viscosity fluids associated mainly with gear oils and can filter oils up to 7,500 SUS @ 100°F (1600 cSt @ 40°C).

SELECTION CHART

Model No.	Description
36970	Portable Cart System
36971	Hand-Held System

FEATURES

Hand-Held System

- **Differential Pressure Gauges** - Indicates when elements need to be changed
- **High Viscosity Oil Sampling Ports** - Two sampling ports available to monitor condition of oil
- **Dual Filters** - Two-stage filtration for long element life and pump protection
- **Compact Frame** - Lightweight design provides flexibility to service equipment located in hard to reach areas
- **Hoses** - Heavy steel wire reinforced clear PVC hoses
- **Gear Pump** - Industrial quality for long life

Portable Cart System

- **Manual Bypass Valve** - Allows transfer of oil without filtering
- **High Viscosity Oil Sampling Ports** - Two sampling ports available to monitor condition of oil
- **Quad Filters** - Four filter elements for increased holding capacity
- **Industrial Strength Tires** - Wide tires capable of getting over large grate gaps
- **Differential Pressure Gauges** - Indicates when elements need to be changed
- **Heavy Duty Cart** - Rugged and built to last
- **Hose & Wand Assembly** - Heavy steel wire reinforced clear PVC hoses with 3' long metal wands
- **Drip Pan** - Keeps work area safe and clean



HIGH-VISCOSITY GEAR & LUBE OIL FILTRATION SYSTEM

SPECIFICATIONS

	Hand-Held System	Portable Cart System
Pump Type	Industrial Grade Gear Pump	Industrial Grade Gear Pump
Flow Capacity	1 GPM	4 GPM
Gear Pump Speed	1725 RPM	1725 RPM
Max. Inlet Vacuum	15" of Mercury	8" of Mercury
Hose Sizing @ 2ft/sec	.75" Diameter Inlet @ 6' Long	1.25" Diameter @ 6' Long
Max. Operating Temperature	150°F (65°C)	150°F (65°C)
Pump By-Pass	85 psi	105 psi
Filter By-Pass	43 psi	43 psi
Max. Viscosity	1600 cSt @ 40°C (7,500 SUS @ 100°F)	1600 cSt @ 40°C (7,500 SUS @ 100°F)
Seal and Gasket Material	Viton®	Viton®
Electrical Service Required*	115 Volts, 10 Amps, Single Phase, 60 Hz	120 Volts, 20 Amps, Single Phase, 60 Hz
Weight	50 lbs	140 lbs
Dimensions	27"W x 13"D x 17"H	28"W x 21"D x 48"H

*220 Available

HAND-HELD FILTER MEDIA

	36976	36977	36978
Micron Rating	3	10	10
Filter Type	Particulate	Particulate	Water
Media Type	Synthetic Micro-Glass	Synthetic Micro-Glass	—
Diameter	3.7"	3.7"	3.7"
Length	8"	8"	8"
Thread	3/4-16 UN-2B	3/4-16 UN-2B	3/4-16 UN-2B
Beta Ratio	Beta 3 ≥ 200 Absolute	Beta 10 ≥ 200 Absolute	10 micron nominal
Dirt Holding Capacity	41 grams	48 grams	N/A
Water Holding Capacity	N/A	N/A	8 oz*

*Based on flow rate and viscosity



PORTABLE FILTER CART MEDIA

	36972	36973	36974	36975
Micron Rating	3	10	20	10
Filter Type	Particulate	Particulate	Particulate	Water
Media Type	Synthetic Micro-Glass	Synthetic Micro-Glass	Synthetic Micro-Glass	—
Diameter	5"	5"	5"	5"
Length	11"	11"	11"	11"
Thread	1-1/2-16 UN-2B	1-1/2-16 UN-2B	1-1/2-16 UN-2B	1-1/2-16 UN-2B
Beta Ratio	Beta 3 ≥ 200 Absolute	Beta 10 ≥ 200 Absolute	Beta 20 ≥ 200 Absolute	10 micron nominal
Dirt Holding Capacity	102 grams	120 grams	125 grams	N/A
Water Holding Capacity	N/A	N/A	N/A	16 oz*

*Based on flow rate and viscosity



PNEUMATIC HIGH-VISCOSITY FILTRATION SYSTEM



The Pneumatic High-Viscosity Filtration System is similar to our standard High-Viscosity Gear and Lube Oil Filtration System except it utilizes a positive displacement pneumatic driven motor to transfer fluids. The Pneumatic High-Viscosity Filtration System is ideal for high-viscosity fluids up to 7,500 SUS @100°F (1600 cSt @ 40°C). It can be used for filtering new fluids during transfer and replenishment, as well as conditioning fluids already in use. A variety of filter element options are available to effectively remove water and particulate contamination.

SELECTION CHART

Model No.	Description
36933	Portable Cart System
36934	Hand-Held System



FEATURES

Hand-Held System

- **Differential Pressure Gauges** - Indicates when elements need to be changed
- **High Viscosity Oil Sampling Ports** - Two sampling ports available to monitor condition of oil
- **Dual Filters** - Two-stage filtration for long element life and pump protection
- **Compact Frame** - Lightweight design provides flexibility to service equipment in hard to reach areas
- **Hoses** - Heavy steel wire reinforced clear PVC hoses
- **Pneumatic Motor** - Air operated motor providing a flow rate of 1 GPM
- **FRL Filter** - Removes debris, moisture and lubricates air to prevent premature wear and failure of motor

Portable Cart System

- **Manual Bypass Valve** - Allows transfer of oil without filtering
- **High Viscosity Oil Sampling Ports** - Two sampling ports available to monitor condition of oil level
- **Quad Filters** - Four filter elements for increased holding capacity
- **Industrial Strength Tires** - Wide tires capable of getting over large grate gaps
- **Differential Pressure Gauges** - Indicates when elements need to be changed
- **Heavy Duty Cart** - Rugged and built to last
- **Hose & Wand Assembly** - Heavy steel wire reinforced clear PVC hoses with 3' long metal wands
- **Drip Pan** - Keeps work area safe and clean
- **Pneumatic Motor** - Air operated motor providing a flow rate of 3 GPM
- **FRL Filter** - Removes debris, moisture and lubricates air to prevent premature wear and failure of motor



PNEUMATIC HIGH-VISCOSITY FILTRATION SYSTEM

SPECIFICATIONS

	Hand-Held System	Portable Cart System
Pump Type	Pneumatic Driven	Pneumatic Driven
Flow Capacity	1 GPM	3 GPM
Air Inlet Connection	1/4" NPT Female	1/4" NPT Female
Max. Operating Pressure	100 psi	100 psi
Maximum Inlet Vacuum	15" of Mercury	8" of Mercury
Hose Sizing @ 2ft/sec	.75" Diameter Inlet @ 6' Long	1.25" Diameter @ 6' Long
Max. Operating Tem	150°F (65°C)	150°F (65°C)
Pump By-Pass	85 psi	105 psi
Filter By-Pass	43 psi	43 psi
Max. Viscosity	1600 cSt @ 40°C 7,500 SUS @ 100°F	1600 cSt @ 40°C 7,500 SUS @ 100°F
Weight	49 lbs.	156 lbs.
Dimensions	27"W x 13"D x 17"H	28"W x 21"D x 48"H
Seals and Gasket	Viton®	Viton®

HAND-HELD FILTER MEDIA

	36976	36977	36978
Micron Rating	3	10	10
Filter Type	Particulate	Particulate	Water
Media Type	Synthetic Micro-Glass	Synthetic Micro-Glass	—
Diameter	3.7"	3.7"	3.7"
Length	8"	8"	8"
Thread	3/4-16 UN-2B	3/4-16 UN-2B	3/4-16 UN-2B
Beta Ratio	Beta 3 ≥ 200 Absolute	Beta 10 ≥ 200 Absolute	10 micron nominal
Dirt Holding Capacity	41 grams	48 grams	N/A
Water Holding Capacity	N/A	N/A	8 oz*

*Based on flow rate and viscosity



PORTABLE FILTER CART MEDIA

	36972	36973	36974	36975
Micron Rating	3	10	20	10
Filter Type	Particulate	Particulate	Particulate	Water
Media Type	Synthetic Micro-Glass	Synthetic Micro-Glass	Synthetic Micro-Glass	—
Diameter	5"	5"	5"	5"
Length	11"	11"	11"	11"
Thread	1-1/2-16 UN-2B	1-1/2-16 UN-2B	1-1/2-16 UN-2B	1-1/2-16 UN-2B
Beta Ratio	Beta 3 ≥ 200 Absolute	Beta 10 ≥ 200 Absolute	Beta 20 ≥ 200 Absolute	10 micron nominal
Dirt Holding Capacity	102 grams	120 grams	125 grams	N/A
Water Holding Capacity	N/A	N/A	N/A	16 oz*

*Based on flow rate and viscosity



LOW-VISCOSITY FILTRATION SYSTEM

The Low-Viscosity Filtration System provides convenient off-line filtration, flushing, conditioning, and fluid transfer of industrial oils. The Low-Viscosity Filtration Systems are available in a cart and hand-held version. The systems are rated for use with lubricants up to a viscosity 2,000 SUS @ 100°F. For added utility, the filtration systems feature differential pressure gauges that indicate when each of the filtration elements needs to be changed. Two sampling ports are included as well for safely sampling and monitoring the condition of oil.



FEATURES

Hand-Held System

- **Oil Sampling Ports** - Two sampling ports available to monitor condition of oil
- **Differential Pressure Gauges** - Indicates when elements need to be changed
- **Dual Filters** - Two-stage filtration for long element life and pump protection
- **Bronze Internal Helical Gear Pump** - Industrial quality for long life
- **Compact Frame** - Lightweight design provides flexibility to service equipment located in hard to reach areas
- **Hoses** - Heavy-duty reinforced clear PVC

SELECTION CHART

36994	Hand-Held System
36989	Portable Cart System

Portable Cart System

- **Bypass Valve** - Allows transfer of oil without filtering
- **Oil Sampling Ports** - Two sampling ports available to monitor condition of oil
- **Manifold System** - Encompasses valves and plumbing in one location
- **Dual Filters** - Two-stage filtration for long element life and pump protection
- **Industrial Strength Tires** - Wide tires capable of getting over large grate gaps
- **Heavy Duty Cart** - Rugged and built to last
- **Pressure Relief Valve** - Prevents over pressurizing and damage to pump, hoses, and filter
- **Check Valve** - Prevents fluid back flow when pump vertically
- **Differential Pressure Gauges** - Indicates when elements need to be changed
- **Hose & Wand Assembly** - Heavy steel wire reinforced clear PVC hoses with 3' long metal (not shown in photo)



LOW-VISCOSITY FILTRATION SYSTEM

SPECIFICATIONS

	Hand-Held System	Portable Cart System
Pump Type	Bronze Internal Helical Gear Pump	Steel Internal Gear Pump
Flow Capacity	5.5 GPM	14 GPM
Electric Motor Rating	½ HP @ 1750 RPM	1-1/2 HP @ 1750 RPM
Maximum Inlet Vacuum	15" of Mercury	8" of Mercury
Hose Sizing	.75" Inlet @ 6' Long / 1.0" Outlet @ 6' Long	1" Inlet and Outlet @ 6' Long
Maximum Operating Temperature	150°F (65°C)	150°F (65°C)
Pressure Relief	50 PSI	100 PSI
Maximum Viscosity	430 cSt @ 40°C / 2000 SUS	430 cSt @ 40°C / 2000 SUS
Seal and Gasket Material	Mechanical – Static	Mechanical – Static
Electrical Service Required	115 Volts, 8.8 Amps, Single Phase, 60 Hz	115 Volts, 15.2 Amps, Single Phase, 60 Hz
Weight	47 lbs	130 lbs
Dimensions	11"W x 20"D x 12"H	28"W x 18"D x 48"H

HAND-HELD FILTER MEDIA

	36976	36977	36978
Micron Rating	3	10	10
Filter Type	Particulate	Particulate	Water
Media Type	Synthetic Micro-Glass	Synthetic Micro-Glass	—
Diameter	3.7"	3.7"	3.7"
Length	8"	8"	8"
Thread	¾-16 UN-2B	¾-16 UN-2B	¾-16 UN-2B
Beta Ratio	Beta 3 ≥ 200 Absolute	Beta 10 ≥ 200 Absolute	10 Micron Nominal
Dirt Holding Capacity	41 grams	48 grams	N/A
Water Holding Capacity	N/A	N/A	8 oz*

* Based on flow rate and viscosity



PORTABLE FILTER CART MEDIA

	36973	36974	36995
Micron Rating	10	20	25
Filter Type	Particulate	Particulate	Water
Media Type	Synthetic Micro-Glass	Synthetic Micro-Glass	—
Diameter	5"	5"	5"
Length	11"	11"	11"
Thread	1-1/2-16 UN-2B	1-1/2-16 UN-2B	1-1/2-16 UN-2B
Beta Ratio	Beta 10 ≥ 200 Absolute	Beta 20 ≥ 200 Absolute	Beta 25 ≥ 200 Absolute
Dirt Holding Capacity	120 grams	125 grams	N/A
Water Holding Capacity	N/A	N/A	23 oz*

* Based on flow rate and viscosity



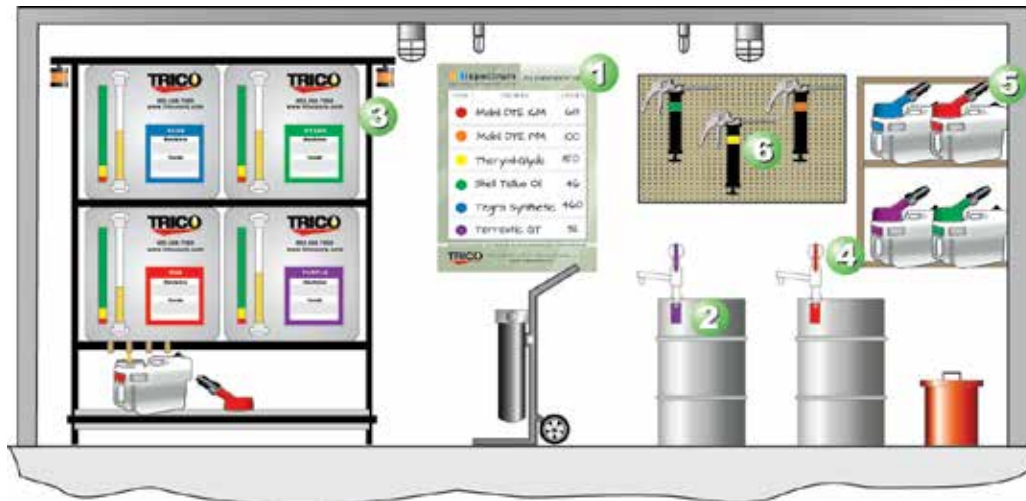
SPECTRUM® VISUAL LUBRICATION MANAGEMENT



A SOLUTION TO MANAGING LUBRICANTS FROM STORAGE TO POINT OF USE

The Spectrum Visual Lubrication Management System uses color coding to ensure the correct lubricant is used in the right piece of equipment, and in the proper location. Colored identifiers can be assigned to designated lubricants. Assigning specific colors allows for a tagging system to be deployed throughout the lubricant chain within the facility. From the point of storage to the point of application, the operator will know which designated lubricant is to go to each specific lubrication point. Color coding lubricants from the time they enter the facility to the point of use will reduce the amount of lubricant cross contamination that occurs in everyday top-ups, re-lubrication, and re-greasing activities. A simple system like this will assist in helping personnel understand the internal supply chain ensuring that the right lubricant gets to the right application.

Spectrum Visual Lubrication Management Products include:



- 1. Spectrum Wall Charts** - Spectrum Wall Charts provide a rewritable surface for designating color to specific lubricants.
- 2. Spectrum Tags and Labels** - A simple and fast solution for identifying lubricants, lubrication points, equipment, and/or anything else you can think of.
- 3. Spectrum Oil Storage System** - These 65 gallon oil storage systems allow for a 55 gallon drum to be transferred into the tanks well before the product is gone.
- 4. EZI-action Drum Pumps** - These pumps provide any easy method of dispensing a wide range of liquids from 5 to 55 gallon containers.

- 5. Spectrum Containers** - These products provide a safe, easy method of transporting, handling, and dispensing lubricants in a wide variety of applications.
- 6. Spectrum Grease Identification Products** - The Grease Identification System uses different color grease fitting caps, washers, and grease gun bands to ensure that the right product is applied to the right locations.
- 7. Opto-Matic Color Bands (not shown above)** - These color collars slide over the upper casting of Trico's Opto-Matic® Oilers and Closed System Oilers for easy identification of lubricant type.



Spectrum Tags and Labels being deployed throughout lube room



Compressor being filled with a Spectrum Container using the hand pump



SPECTRUM® TAGS AND LABELS

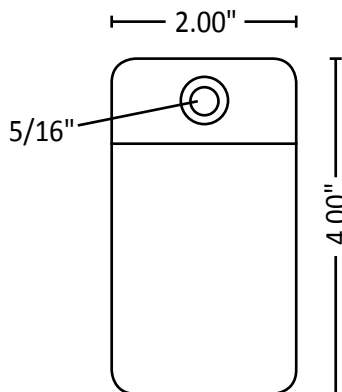
Avoid lubricant cross contamination and misapplication with Spectrum Tags and Labels. The Spectrum Tags and Labels provide a simple and fast solution for indentifying lubricants from storage to point of use. These easy to use, durable color-coded tags and labels can be used for marking everything from storage containers and drums, transport containers, hand pumps, filter carts, transfer carts, dispensing equipment and tools, machinery, lubrication points or anything else you can think of. Use a felt tip marker, crayon, or Spectrum customized label to mark the tag with your information. Then simply seal the information beneath the laminate sheet to keep it clean and legible. The Spectrum labeling system allows you to create customized labels using various colors, text and **barcoding** for your specific requirements.

CUSTOMIZED LABEL

All you need to do is supply the data file for your custom Spectrum label, and we'll do the rest! Let us know if you want the label with or without barcoding.

FEATURES

- Color-coded solution for identifying containers, dispensers, filter carts, equipment, machinery lubrication points, etc
- Durable Spectrum Tags are weather and chemical resistant to withstand the most demanding indoor and outdoor use
- Spectrum Tags are made of durable 1/16" UV inhibited plastic with a tough clear laminate that withstands acids, caustics, oils, and abrasions
- Spectrum Custom Labels can contain up to four lines of information including a barcode



Part of the Spectrum Visual Lubrication Management Products that use color coding to ensure the correct lubricant is used in the right piece of equipment, and in the proper location. Combine Spectrum Tags and Labels with other Spectrum Products for effective lubrication management from storage to point of use. For more Spectrum Products, look for the Spectrum logo.

TAG SPECIFICATIONS

Tag Size	2"W x 4"H
Tag Material	1/16" UV inhibited plastic
Grommet Size	5/16" Diameter
Colors	Available in 10 colors



Spectrum Tags and Labels are used to identify grease lines for Automatic Grease Dispensers.



SPECTRUM® TAGS AND LABELS



1.

Lift the flap portion with backing still affixed to protective laminate seal.



2.

Write your specific wording on tag surface using a marker, crayon, or Spectrum Custom Label.



3.

Remove the backing and affix laminate over your message.



4.

Your newly created tag is ready for installation.

Spectrum Tags and Labels are easy to use—a 4-step process



Part of the Spectrum Visual Lubrication Management Products that use color coding to ensure the correct lubricant is used in the right piece of equipment, and in the proper location. Combine Spectrum Tags and Labels with other Spectrum Products for effective lubrication management from storage to point of use. For more Spectrum Products look for the Spectrum logo.

SELECTION CHART—SPECTRUM CUSTOM LABELS

Model No.	Description
37085	Spectrum Custom Labels – Sheet of 18
37086	Spectrum Custom Labels with barcoding – Sheet of 18



Spectrum Tag on a Watchdog Desiccant Breather

SELECTION CHART—SPECTRUM TAGS

Model No.	Tag Color
37075	Red
37076	Orange
37077	Yellow
37078	Green
37079	Blue
37080	Purple
37081	Dark Green
37082	Tan
37083	Gray
37084	Black

LABEL SPECIFICATIONS

Custom Label Size	1-1/4" W x 2-3/8" H
Labels	Sheet quantity (18 per sheet)
Barcode formats available	Code 39
	Code 39 Extended
	Code 128 A, B, C, and Auto
	UCC/EAN 128
	Interleaved 2 of 5
	Standard 2 of 5
	Code 93
	Code 11
	Codabar
	UPC A
	UPC E
	EAN 13
	EAN 8



Spectrum Tag with customized barcoding label



SPECTRUM® OIL STORAGE SYSTEM

Trico's Spectrum Oil Storage System (SOSS) is your streamlined solution for the identification, transfer, storage and dispensing of your oils and plant lubricants.

The SOSS is an innovative, economical bulk oil storage system that allows you to save space on your plant floor, while keeping your lubricants contaminate free. This system is flexible to constricted space requirements and was designed with allowable expansion off of the base units. It also eliminates the potential for lubricant mess and mishandling – keeping each drum clearly identified using our exclusive Spectrum color-coded tags and labels (refer to pages 26–27).

The Spectrum Oil Storage System is a reliability tool exclusively from Trico – yet another way we've found to keep your people and your machines running lean and productive.



Color-coded labels and tags identify oil type to ensure the right lubricant is delivered to the right equipment.

spectrum

VISUAL LUBRICATION MANAGEMENT SYSTEM

The Spectrum Oil Storage System is part of the Spectrum Visual Lubrication Management of products that use color coding to ensure the correct lubricant is used in the right piece of equipment, and in the proper location. Combine the Spectrum Oil Storage System with other Spectrum products for effective lubrication management from storage to point of use.



FEATURES

- Available in four basic, 65 gallon tank configurations – 4, 6, 8, and 12
- 1-1/2" Polyurethane lines and Polyethylene shutoff valve—standard on all systems
- Dispensing valves - standard self closing bronze valves with quick coupling adapters for tank filling
- Single drip tray - contains spillage from valve assemblies while dispensing
- Motor and pump combination draw less than 14.5 amps allowing the system to be placed on a 15 amp circuit
- Bronze gear pump - positive displacement and self priming
- Desiccant breathers - prevents moisture and particulate contamination from entering tanks
- Optional spill containment - exceeds the requirements set by EPA standards



SPECTRUM® OIL STORAGE SYSTEM

SPECIFICATIONS

Fluid Capacity Per Tank	65 Gallons
Storage tank	Powder coated alumni steel
Frame	Powder coated steel
Sight Gauge	Brass/Stainless
Breather Manifold Assembly	100 cu in
Motor	1-1/2 HP TEFC
Gear Pump Speed	1725 RPM
Amp Draw	14.5 A
Voltage	110/ 220 V
Maximum Viscosity	ISO 680 @ 40°C
Minimum Flashpoint	150°F
Containment Capacity per largest spill container (optional)	>110%
Tank Lines	1-1/2" Polyurethane
Tank Shut-Off Valves	Polyethylene
Valve Assembly	Self Closing 1" Bronze

OPTIONAL ITEMS

SPILL CONTAINMENT

Heavy duty steel constructed spill containment pans are an environmentally-friendly solution to costly spill clean-ups. Spill containment systems are built to exceed EPA regulations.

QUICK DISCONNECT KIT

Quickly and easily disconnect hoses while transferring fluid to system tanks.

STAINLESS STEEL TANK UPGRADE

Provide corrosion resistance for water-based fluids.

FIRE SAFETY COMPLIANCE KIT

To maintain compliance with strict fire safety regulations, we offer the Fire Safety Compliance Kit. The standard PVC hose, underneath the tanks, are replaced with ¾" NPT fittings and flex steel hose that connects to a fusible link valve with spring activated handle. If the temperature reaches 166°F, the handle is automatically triggered and shuts off any possible leakage of fluid from the tank.

SELECTION CHART—SYSTEMS

Model No.	Number of Containers	Tank Arrangement	Depth	Width	Height	Floor Area
36781	4	2 rows of 2 containers	43"	54"	100"	16.1 sq ft
36782	6	2 rows of 3 containers	43"	76"	104"	22.7 sq ft
36783	8	2 rows of 4 containers	43"	101"	104"	30.2 sq ft
36784	12	3 rows of 4 containers	43"	101"	160"	30.2 sq ft

OPTIONAL ITEMS

Model No.	Description
36785	Spill Containment, 4 Tank System
36786	Spill Containment, 6 Tank System
36787	Spill Containment, 8 or 12 System
36791	Fire Safety Compliance Package, Per Tank
36239	Quick Disconnect Kit, 4 Tank System
36240	Quick Disconnect Kit, 6 Tank System
36241	Quick Disconnect Kit, 8 Tank System
36242	Quick Disconnect Kit, 12 Tank System
36792	Stainless Steel Tank Upgrade (316 ss), Per Tank



Sight gauge and graduation level label provides indication of remaining fluid



EZI-ACTION DRUM PUMPS

EZI-action Drum Pumps provide an easy method of dispensing a wide range of liquids including strong acids, alkalis, mild solvents, lubricants, oils, and diesel to name a few from 5 gallon containers to 55 gallon drums. The pumps dispense fluid on both the up and down stroke with only two moving parts. Patented zero-friction design provides effortless flow of viscous fluids up to 8,800 cps. The pumps are ruggedly constructed with polypropylene and polyethylene to perform in hostile conditions. Each EZI-action Drum Pump is supplied with the appropriate adapters for quick and easy installation.

All EZI-action Drum Pumps feature a safety strap, which locks the pump handle in the closed position to prevent accidental discharge of liquids when not in use. Optional color-coding of the Safety Strap, when used in conjunction with fluid transferring and dispensing containers, such as Spectrum® Containers, minimize the risk of fluid cross-contamination and ensures the right lubricant is used in your equipment.

FEATURES

- Easy to install, safe to use, and simple to maintain
- Fits 5 to 55 gallon containers
- Pumps liquid on both the “up” and “down” strokes
- Sits on the base of the container
- Prevents undesired fluid drip
- Pumps high viscosity liquids
- Optional color-coding system available
- No wearing parts
- Not to be used with highly flammable liquids, strong solvents, or gasoline

SPECIFICATIONS

Material	Polypropylene and Polyethylene
Max. Viscosity	8,800 cps
Max. Flow	5-6 Gallon Drum Pump – 6 oz per stroke 15-30 Gallon Drum Pump – 15 oz per stroke 15-55 Gallon Drum Pump – 15 oz per stroke

SELECTION CHART—EZI-ACTION DRUM PUMPS

Model No.	Tank Capacity
36980	15-55 gallon containers
36981	15-30 gallon containers
36982	5-6 gallons containers



EZI-action Drum Pump with optional color coded Safety Strap



Optional color-coding of the Safety Strap, when used in conjunction with fluid transferring and dispensing containers, such as Spectrum Containers, minimize the risk of fluid cross-contamination and ensures the right lubricant is inserted into the right piece of equipment.

SELECTION CHART—COLOR CODED SAFETY STRAPS

Model No.	Color
36983	Yellow
36984	Red
36985	Blue
36986	Green
36987	Orange
36988	Purple



Part of the Spectrum Visual Lubrication Management Products that use color coding to ensure the correct lubricant is used in the right piece of equipment, and in the proper location. Combine EZI-action Drum Pumps with other Spectrum Products for effective lubrication management from storage to point of use. For more Spectrum Products look for the Spectrum logo.



SPECTRUM® OIL CONTAINERS



Spectrum Oil Containers providing a simple, easy-to-use and error-free solution to store, identify, transport and dispense lubricants. They offer users an excellent way to keep lubricants free from dust, dirt, water and other machine-damaging contaminants. They play an important role in the lubrication supply chain, especially between bulk containers and top-off points, which industry experts indicate to be the most common source of contamination.

- Color coded on/off breather vent
- Square design allows for stability when using hand pump
- Ergonomically contoured container to fit forearm
- Up to 100 colors options with combination of lid and vent colors

PRODUCT SELECTION



PUMP STORAGE LID

This multi-purpose lid allows rapid pouring of oils, making it ideal for topping off machinery such as crankcases or large engine blocks. Fitting the Hand Pump to the Pump Storage Lid will allow lubricant to be pumped out of 2, 3, and 4 gallon containers.



1" NOZZLE LID

Ideal for topping-off engines, crankcases, and other areas where higher flow is required.



1/2" NOZZLE LID

Ideal for use with oils having viscosities up to ISO 460 or where precise pouring is required.



1/4" NOZZLE LID

Ideal for controlled pouring into small reservoirs or filler holes.

SPECIFICATIONS

O-ring	Buna-N
Temperature Range	-40°F to 176°F
Material	High Density Polyethylene
Additives	UV stabilizer

NOT SUITABLE FOR USE WITH FUELS OR SOLVENTS



CONTAINERS – 2, 3, 4 GL (8, 11, 15 L)

These robust and durable containers feature a wide opening for rapid no-spill filling and will fit any lid. The containers are semi-transparent with graduated markings along the side making lubricant level easy to see. Each container comes with a writable "CONTENTS" label to provide easy identification of lubricant type.



HAND PUMP

Ideal for awkward or hard to reach oil top-off applications such as gearboxes, lathes, and milling machines. Supplied with outlet hose and anti-drip nozzle. Simply fit the Hand Pump to a Pump Storage Lid and mate with a 2, 3, or 4 gallon container.



BREATHER VENT

The Breather Vent is available in ten colors to coordinate with lid color or to use as a secondary color option (ex. for identifying viscosity grade, lubrication frequency, or base oil type). All 2, 3, 4 gallon containers are supplied with a black Breather Vent as standard.

SELECTION CHART—LIDS

Description	Yellow	Red	Blue	Green	Black	Orange	Purple	Gray	Tan	Dark Green
Pump Storage Lid	34430	34431	34432	34433	34434	34435	34436	34437	34438	34439
1" Nozzle Lid	34420	34421	34422	34423	34424	34425	34426	34427	34428	34429
1/2" Nozzle Lid	34410	34411	34412	34413	34414	34415	34416	34417	34418	34419
1/4" Nozzle Lid	34400	34401	34402	34403	34404	34405	34406	34407	34408	34409
Breather Vent	24011	24012	24013	24014	24010	24015	24016	24017	24018	24019

SELECTION CHART

Model No.	Description
34460	2 gl container (8 l)
34461	3 gl container (11 l)
34462	4 gl container (15 l)
34463	Hand Pump



SPECTRUM® OIL CONTAINERS



CAPACITY

2

gallon
(8 liters)

3

gallon
(11 liters)

4

gallon
(15 liters)



Part of the Spectrum Visual Lubrication Management Products that use color coding to ensure the correct lubricant is used in the right piece of equipment, and in the proper location. Combine Spectrum® Containers with other Spectrum Products for effective lubrication management from storage to point of use. For more Spectrum Products look for the Spectrum logo.



SPECTRUM GREASE IDENTIFICATION PRODUCTS

Too often the wrong grease is put into the wrong piece of equipment, which can cause an incompatibility problem that can quickly lead to bearing failure. Avoid cross contamination and misapplication with Trico's Grease Identification System. Trico's Grease Identification System ensures you are receiving the right product at the right location.



Grease Gun Bands
Color grease gun bands slide over standard grease guns and do not slip after being installed. Color code grease guns to match grease fitting caps and/or washers on equipment to avoid cross-contamination and mis-application of grease.



Grease Fitting Washers
Color grease fitting washers are available in two sizes to fit 1/8" NPT or 1/4-28 grease fittings.



Grease Fitting Caps
Grease fitting caps snap securely over grease fittings to seal out dirt and moisture. Integral retaining ring keeps cap in place during servicing.

SELECTION CHART

	Red	Orange	Yellow	Green	Blue	Purple
Buna-N Grease Gun Band	37038	37056	37036	37037	37039	37044
Buna-N Washer for 1/4-28 Grease Fittings (sold in 10 packs)	37030	—	—	37029	37031	—
Buna-N Washer for 1/8 NPT Grease Fittings (sold in 10 packs)	37034	—	37032	37033	37035	—
Grease Fitting Cap for 1/4-28 Grease Fittings (sold in 10 packs)	37022	37057	37020	37021	37023	37040
Grease Fitting Cap for 1/8 NPT Grease Fittings (sold in 10 packs)	37026	37058	37024	37025	37027	37041



RIGHT PRODUCT – Identify grease guns to ensure that the correct type of grease is used at each grease point.

RIGHT LOCATION – Apply color washers and/or caps to all grease points to avoid cross contamination and misapplication.



Part of the Spectrum Visual Lubrication Management Products that use color coding to ensure the correct lubricant is used in the right piece of equipment, and in the proper location. Combine Spectrum Grease Identification Products with other Spectrum Products for effective lubrication management from storage to point of use. For more Spectrum Products look for the Spectrum logo.



SPECTRUM OPTO-MATIC COLLARS

Spectrum Opto-Matic Collars slide over the upper casting of Trico's Opto-Matic Oilers and Closed System Oilers for easy identification of lubricant type. Color-code constant level oiler to match lubricant dispensing containers, such as Spectrum®, to avoid cross-contamination and misapplication of lubricant.

FEATURES

- Made from Buna-N material
- Conveniently sold in packs of ten

SELECTION CHART

Model No.	Color
37050	Yellow
37051	Green
37052	Red
37053	Blue



Part of the Spectrum Visual Lubrication Management Products that use color coding to ensure the correct lubricant is used in the right piece of equipment, and in the proper location. Combine Spectrum Opto-Matic Collars with other Spectrum Products for effective lubrication management from storage to point of use. For more Spectrum Products look for the Spectrum logo.



INDUSTRIAL FAST FUNNEL®

Trico's Industrial Fast Funnels are the simple, convenient and clean way to pour. Intended for one-time use, each funnel remains clean and compact until separated from the header and opened. Made of coated, heavy grade paper stock, they can be used with most lubricants and liquids and are designed to fit a wide variety of orifices as small as 3/4" diameter.

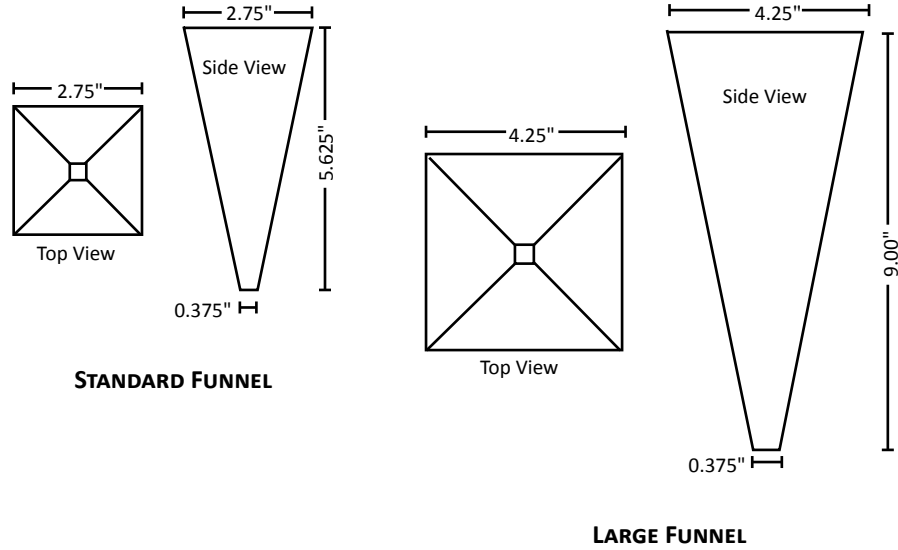
FEATURES

- Improves safety and efficiency by preventing spills on floors and equipment
- Available in two convenient sizes, standard and large
- Easily stores and remains clean in any toolbox, cabinet, pocket, etc.
- Conveniently packaged in handy three-packs
- Fast Funnels are biodegradable
- Simply tear-off, pop open, and pour



SELECTION CHART

Model No.	Description	Quantity of 3-Packs	Total No. of Funnels
36990	Standard Size Fast Funnel—Interpack	12	36
36991	Large Size Fast Funnel—Interpack	12	36
36992	Standard Size Fast Funnel—Case	288	864
36993	Large Size Fast Funnel—Case	144	432



The flow can be increased on the Industrial Fast Funnels by cutting at the preprinted lines.



OIL ABSORBENTS



PERFORATED ROLLS

Perforated rolls are ideal for leaks, drips and overspray while allowing for more surface area coverage than pads. Perforated every 30" for quick and easy tearing. These lint-free rolls will not contaminate your equipment and they are tough enough for foot traffic.

Part Number	Absorbency	Size	Package Size	Absorption Capacity/Package	Package Weight
30178	Universal	30" x 150'	1 roll	38 gal.	27 lbs.
30181	Oil Only	30" x 150'	1 roll	50 gal.	33 lbs.
30183	Camo	30" x 150'	1 roll	52 gal.	35 lbs.

ORGANIC CORN COB SOCK

The corn cob socks are ideal for use around leaking machines or ones that spray fluid. Socks are also used to contain spills before they become hazardous. Organic corn cob provided superior absorbency.



Part Number	Absorbency	Size	Package Size	Absorption Capacity/Package	Package Weight
30185	Universal	3"W x 48"L	40	25 gal.	60 lbs.

ABSORBENT PADS

Absorbent pads are ideal to control everyday leaks and spills. They have a perforation down the middle, allowing you to take what you need.

The dimple pattern speeds wicking of liquid throughout the pad faster and provides durable construction to prevent tearing during clean-up.



Part Number	Absorbency	Size	Package Size	Absorption Capacity/Package	Package Weight
30177	Universal	16" x 20"	100 pads	23 gal.	16 lbs.
30180	Oil Only	16" x 20"	100 pads	30 gal.	20 lbs.
30184	Camo	15" x 19"	200 pads	32 gal.	19 lbs.

HELPFUL TIP:

Universal absorbents will absorb most fluids (oil, coolants, water, etc). Oil only absorbents will only absorb oil. Camo absorbents will absorb most fluids (oil, coolants, water, etc) and are ideal for foot traffic.

DRUM TOP PADS

Eliminate messy drips and overflow when pumping fluids from drums with these drum topper pads. They keep drum tops clean and grime free. The 55-gallon drum topper pads contain two pre-cut bung holes making placement of pad and drum access easy.



Part Number	Absorbency	Size	Package Size	Absorption Capacity/Package	Package Weight
30179	Universal	22" dia.	25 pads	7 gal.	6 lbs.
30182	Oil Only	22" dia.	25 pads	7 gal.	6 lbs.



INTRODUCTION TO GRAVITY FEED OILERS

The purpose of gravity feed lubrication is to provide a reliable and continuous supply of oil to bearings, gears, chains, and other rotating or moving machinery components. As the name applies, these systems operate using gravity feed principle. A supply reservoir is used to feed lubricant through piping, by means of gravity, to the point of lubrication. These systems can also consist of a number of manifolds or distribution centers from which oil is directly piped to the surface to be lubricated. Each point has its own independent piping and set of connections. Gravity feed lubrication is an alternate means of lubricating machinery components rather than using automatic systems such as centralized lubrication. The method of employing gravity feed lubrication consists of drip-feed, chain, and wick feed lubrication.



Chain oiler lubricating a chain on a trommel screen

DRIP-FEED OILERS: A drip-feed oiler consists of a simple reservoir mounted in a convenient position for filling, while allowing the piping to be connected to the point of lubrication. Typically the rate of feed, to each lubrication point, is regulated by a needle valve, which is manually adjustable. In addition, manifolds can be used with drip-feed oilers to supply lubricant to multiple points.

CHAIN OILERS: Chain oilers automatically apply a film of lubricant to chains, gears, slides, irregular surfaces or out-of-the-way oscillating parts. They greatly reduce link wear, stretch, friction, rust, and corrosion. Chain oilers are similar in operation to drip-feed oilers however; they contain an applicator to supply lubricant to the source. Applicators are available in a variety of styles for both lubricating and cleaning purposes of the chain.

WICK FEED OILERS: Wick feed oilers combine gravity feed with capillary action to provide a constant rate of oil to the lubricating point, regardless of fluid level in the reservoir. The capillary action is provided by the use of various wick sizes. The rate of feed is adjusted with the use of different wick sizes or viscosity of oil.

Gravity feed oilers bring the benefits of automatic lubrication without the high cost. They provide a simplistic, yet reliable method, of keeping component parts of industrial machinery lubricated. Trico offers a wide range of gravity feed oilers for lubricating single or multiple points and for use in conjunction with brush applicators.



Gravity feed oiler on drying machine



Gravity feed oilers on a mud washing drum

GRAVITY FEED OILERS

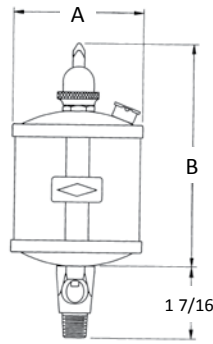
The gravity feed oilers work in a wide range of industrial lubricating applications. The rate of oil feed is adjustable and a lock ring maintains the setting. In bearing or gear lubrication, the gravity feed oilers provide dependable lubrication in the most demanding environments.



37016

FEATURES

- Three position toggle switch provides easy to use on-off control, and a flushing option to avoid dry start-ups
- Vented sight chamber ensures proper operation when used with tight or high speed bearings
- Copper brazing of all steel connections provides long life and leak proof design



KG

KG

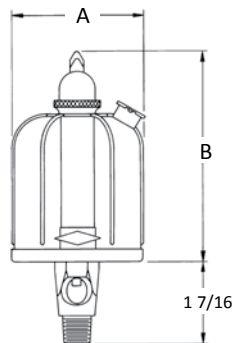
- Heavy wall glass reservoirs and sight chambers operate continuously at 250°F
- Nickel plating offers superior corrosion resistance



30325

KL

- Plastic reservoirs have reinforced ribs for long life and impact resistance
- Zinc plating resists corrosion



KL

SPECIFICATIONS—KG

Max. Operating Temp.	250°F Continuous
Reservoir	Heavy Wall Heat Resistant Glass
Oil Sight	Heavy Wall Heat Resistant Glass
Gaskets	Buna-N
Materials	Heavy Gauge Steel
Finish	Bright Nickel Plate
Needle Valve	Steel

SELECTION CHART—KG

Model No	Capacity	Connection (NPT)	Dimensions (in.)	
			A	B
37011	1 oz.	1/8	1-5/8	3-1/4
37012	1 oz.	1/4	1-5/8	3-1/4
37013	2.5 oz.	1/8	2-1/8	4
37014	2.5 oz.	1/4	2-1/8	4
37015	5 oz.	1/8	2-5/8	4-5/8
37016	5 oz.	1/4	2-5/8	4-5/8
37017	5 oz.	3/8	2-5/8	4-5/8
37018	10 oz.	1/4	3-1/8	5-3/8
37019	10 oz.	3/8	3-1/8	5-3/8

SPECIFICATIONS—KL

Max. Operating Temp.	165°F Continuous
Reservoir	Butyrate Plastic
Oil Sight	Acrylic Plastic
Sight Gaskets	Buna-N
Materials	Steel and Brass
Finish	Bright Zinc Plated
Needle Valve	Steel

SELECTION CHART—KL

Model No	Capacity	Connection (NPT)	Dimensions (in.)	
			A	B
30322	2 oz.	1/8	1-15/16	3-1/16
30323	2 oz.	1/4	1-15/16	3-1/16
30324	4 oz.	1/8	2-5/16	3-7/8
30325	4 oz.	1/4	2-5/16	3-7/8
30326	4 oz.	3/8	2-5/16	3-7/8
30327	8 oz.	1/8	2-5/8	4-15/16
30328	8 oz.	1/4	2-5/8	4-15/16
30329	8 oz.	3/8	2-5/8	4-15/16



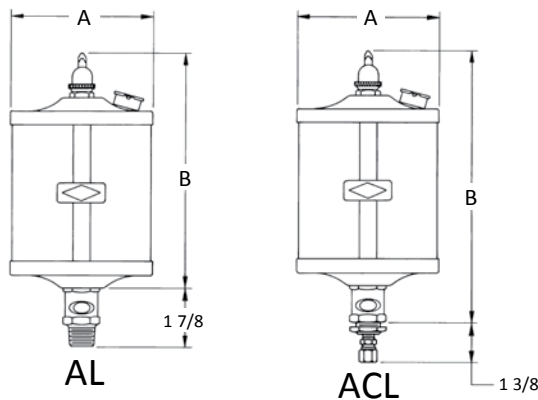
ATLAS GRAVITY FEED OILERS

The Atlas gravity feed oiler is used in heavy-duty applications where a large oil capacity is needed and an adjustable rate of oil is required. Silver brazed construction of the reinforced brass assembly provides long life in high vibration applications.

The Atlas oiler is adjustable for varying rates of oil flow used in bearing or machinery lubrication. The adjustable drip rates are easily set and controlled with a lock ring for maximum versatility.

FEATURES

- Heavy wall heat resistant glass reservoirs and sights providing service in temperatures to 250°F
- Acrylic reservoir versions have heavy walls for long life in applications to 165°F
- Three position toggle switch provides easy to use on-off control, and a flushing option to avoid dry start-ups
- Direct mounting with NPT threads (AL) or remote mounting with 3/4-16 mounting stud and 1/4" tubing connections (ACL) simplifies installation
- Silver brazing of all brass construction provides long life and leak proof design
- Clear lacquer finish resists corrosion



SPECIFICATIONS

Max. Operating Temp.	Glass 250°F Continuous Acrylic 165°F Continuous
Reservoir	Heavy Wall Heat Resistant Glass Heavy Wall Acrylic Plastic
Oil Sight	Heavy Wall Heat Resistant Glass Heavy Wall Acrylic Plastic
Gasket	Buna-N
Material	Brass
Finish	Lacquered Satin Finish
Needle Valve	Brass

SELECTION CHART —AL

Locking Ring Mechanism - Direct Mounting

Model No.		Capacity	Connection (NPT)	Dimensions (in.)	
Glass	Acrylic			A	B
31517	31416	1 pt.	3/8	4-7/16	4-5/16
31518	31417	1 pt.	1/2	4-7/16	4-5/16
31543	31432	1 qt.	1/2	4-7/16	7-5/8
31581	31480	2.5 qt.	1/2	5-11/16	9-3/4
—	31481	1 gal.	1/2	5-11/16	14-13/16

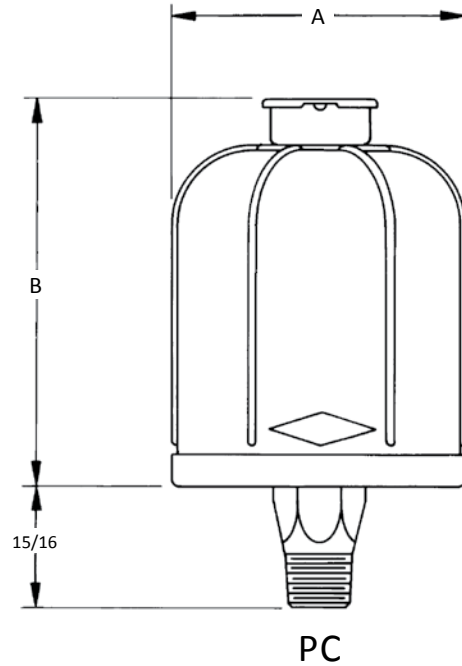
SELECTION CHART—ACL

Locking Ring Mechanism - Remote Mounting - 1/4" tube connector furnished.

Model No.		Capacity	Mounting Stud	Dimensions (in.)	
Glass	Acrylic			A	B
32117	32016	1 pt.	3/4-16	4-7/16	5-5/16
32133	32032	1 qt.	3/4-16	4-7/16	8-11/16
32181	32080	2.5 qt.	3/4-16	5-11/16	10-13/16
—	32081	1 gal.	3/4-16	5-11/16	15-7/8



PC OIL CUP



PC oil cups serve a dual purpose of providing a small oil reservoir or being used as an oil gauge. The PC oil cup is ideal for applications where it can be directly mounted to a bearing housing, gear box or any other industrial equipment that requires lubricant.

FEATURES

- Dust proof, self-closing fill caps supplied with all models
- Plastic reservoirs have reinforcing ribs for long life and impact resistance
- Copper brazing of all steel connections provides long life and leak proof design
- Zinc plating resists corrosion

SPECIFICATIONS

Max. Operating Temp.	165°F Continuous
Reservoir	Butyrate Plastic
Material	Steel
Finish	Bright Zinc Plated

SELECTION CHART

Model No	Capacity	Connection (NPT)	Dimensions (in.)	
			A	B
31121	2 oz.	1/8	1-15/16	3-1/16
31122	2 oz.	1/4	1-15/16	3-1/16
31141	4 oz.	1/8	2-5/16	3
31142	4 oz.	1/4	2-5/16	3
31143	4 oz.	3/8	2-5/16	3
31181	8 oz.	1/8	2-5/8	4
31182	8 oz.	1/4	2-5/8	4
31183	8 oz.	3/8	2-5/8	4



VARI-FEED WICK OILERS



Vari-Feed wick oilers are used to provide a controlled amount of oil to a bearing or other machinery part. The principle of delivery combines gravity feed with capillary action in the wick to provide a constant feed rate of oil regardless of the fill level in the reservoir. Feed rate is determined by the viscosity of the oil and the type of wick being used.

Two styles of operation are available depending on the application. When continuous delivery is required the N or NS models are used.

For on-off control of the oiler, the NA and NAS models have a filler cap with gasket that stops oil delivery when fully closed. By turning the fill cap slightly, the threaded air vent is opened allowing oil to flow.

FEATURES

- Feed rate is constant and adjustable only by changing to a different wick
- 5 wick speeds are available and color coded for easy replacement or installation. A multi-pack of different wick speeds is included with each oiler
- Dust proof caps supplied with N and NS models. NA and NAS models have sealed cap and operate only when cap is in vent position
- Plastic reservoirs have reinforcing ribs for long life
- Oil sights available on NS and NAS models for visual indication of oil flow
- Copper brazing of all steel connections provides long life and leak proof design
- Zinc plating resists corrosion

SPECIFICATIONS

Max. Operating Temp.	165°F Continuous
Reservoir	Butyrate Plastic
Oil Sight	Acrylic
Sight Gaskets	Buna-N
Wicking	Wire Cored Cotton
Material	Steel and Brass
Finish	Bright Zinc Plated

SELECTION CHART—N, NS

Model No.		Capacity	Connection (NPT)	Dimensions (in.)	
Type N	Type NS			A	B
30742	30842	4 oz.	1/4	2-5/16	3
30782	—	8 oz.	1/4	2-5/8	4

SELECTION CHART—NA, NAS

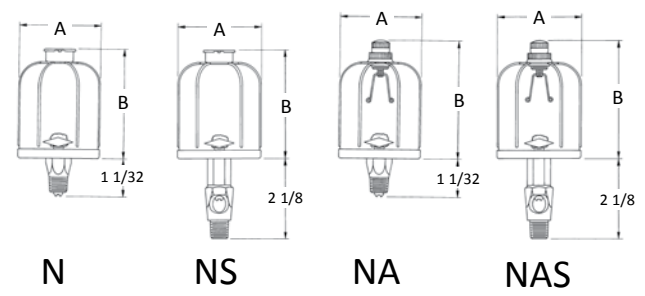
Model No.		Capacity	Connection (NPT)	Dimensions (in.)	
Type NA	Type NAS			A	B
30942	31042	4 oz.	1/4	2-5/16	3-1/4
—	31082	8 oz.	1/4	2-5/8	4-5/16

REPLACEMENT WICKS

Packed 50 of one color per carton. Also sold by the foot.

Model No.	Length	Description	Thickness
30701	1-3/8"	White - Very Fast Feed Wick	3 mm
30702		Green/White - Fast Feed Wick	5 mm
30703		White/Blue - Medium Feed Wick	6 mm
30704		Red/White - Slow Feed Wick	8 mm
30705*		White/Blue - Very Slow Feed Wick	12 mm

*Contains 100 pieces of white/blue wicks

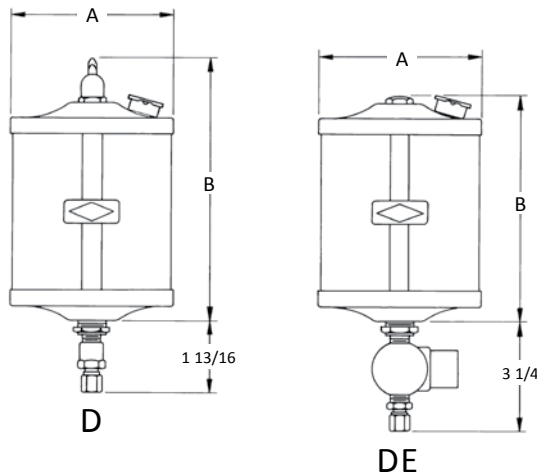


D & DE FULL FLOW DISPENSERS

Trico full flow dispensers are used to lubricate bearings, chains, and other machinery parts when remote valves or manifolds are used. This allows for easy access to the oil reservoir when the valve or manifold is located in a difficult to reach spot. These dispensers are also used in applications where multiple point lubrication is required from one reservoir of oil. With heavy wall acrylic or heat resistant glass reservoirs, and all brass construction, they operate in a wide range of applications. In applications requiring automatic control of the oiler, solenoid versions are available.

FEATURES

- Toggle shut-off (D model) provides easy to use manual control
- Solenoid version (DE model) allows machine interface for maximum versatility
- Mounting stud simplifies installation to customer supplied bracket
- Acrylic reservoirs are heavy wall design for service to 165°F. Heat resistant glass reservoirs operate in temperatures to 250°F.
- Silver brazing of all brass construction provides long life and leak proof design
- Clear lacquer finish of brass components resists corrosion



SELECTION CHART—D

Manual Control - 1/4 Tube Connector Furnished.

Model No.		Capacity	Mounting Stud	Dimensions (in.)	
Glass	Acrylic			A	B
35562	35563	1 pt.	3/4-16	4-7/16	4-5/16
35564	35565	1 qt.	3/4-16	4-7/16	7-3/16
35566	35567	2.5 qt.	3/4-16	5-11/16	9-5/16
—	35569	1 gal.	3/4-16	5-11/16	14-5/16

ACCESSORIES V series valves and VM manifolds are ordered separately, please see V series valves and VM manifolds document. Applicators are ordered separately, please see Applicators document at the end of this section.

SPECIFICATIONS

Max. Operating Temp.	Glass 250°F Continuous Acrylic 165°F Continuous
Reservoir	Heavy Wall Heat Resistant Glass Heavy Wall Acrylic Plastic
Gasket	Buna-N
Material	Brass
Finish	Lacquered Satin Finish
Solenoid	Stainless Steel Plunger and Brass Body UL/CSA Listed
Needle Value	Brass

SELECTION CHART—DE

Electric Control - 1/4 Tube Connector Furnished.—See "How to Order"

Model No.		Capacity	Mounting Stud	Dimensions (in.)	
Glass	Acrylic			A	B
35572	35573	1 pt.	3/4-16	4-7/16	3-5/16
35574	35575	1 qt.	3/4-16	4-7/16	6-3/16
35576	35577	2.5 qt.	3/4-16	5-11/16	8-5/16
—	35579	1 gal.	3/4-16	5-11/16	13-5/16

SOLENOID VOLTAGE

Designator	Voltage
B	120V 60 Hz

HOW TO ORDER

Using the solenoid voltage chart, add a "B" to the model number to specify the correct voltage on solenoid versions.

Other Voltages and Frequencies Available. Consult Factory.



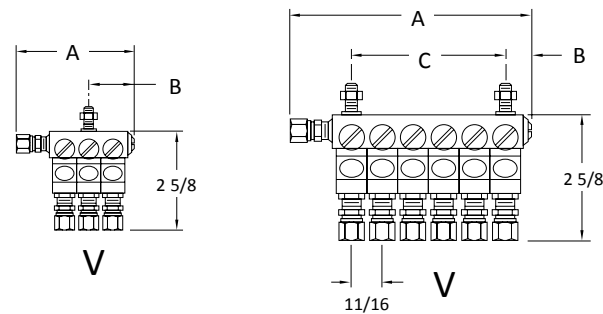
V SERIES VALVES & VM MANIFOLDS

V series valves are used with full flow dispensers where feed rate adjustment is desired at the point of lubrication.

VM series manifolds are used with full flow dispensers and allow Trico applicators to be mounted directly to them. With adjustable adapters and integral needle valves, these manifolds allow easy setting at the point of lubrication.

FEATURES

- Horizontal design of needle valve minimizes contamination at the valve seat
- Clean out plugs provide easy cleaning when required
- Heavy wall acrylic or heat resistant glass sights allow easy setting of the desired drip rate
- Silver brazing of all brass construction provides long life and leak proof design



SPECIFICATIONS

Max. Operating Temp.	Glass 250°F Continuous Acrylic 165°F Continuous
Oil Sight	Heavy Wall Heat Resistant Glass Heavy Wall Acrylic Plastic
Gasket	Buna-N
Packing Gland	Graphite
Material	Brass
Finish	Lacquered Satin Finish
Needle Valve	Brass

SELECTION CHART—V SERIES VALVES

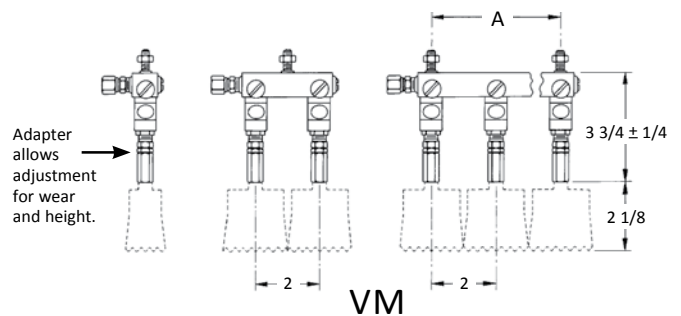
1/4 Tube Connector Furnished

Model No.		No. of Valve Outlets	Mounting Stud	Dimensions (in.)		
Glass	Acrylic			A	B	C
30171	30271	1	1/4-20	2	5/8	—
30172	30272	2	1/4-20	2-11/16	31/32	—
30174	30274	4	1/4-20	4-1/16	1-21/32	—
30176	30276	6	1/4-20	5-7/16	5/8	3-7/16

SELECTION CHART—VM MANIFOLDS

1/4 Tube Connector Furnished

Model No.		No. of Valve Outlets	Mounting Stud	Dimensions (in.)
Glass	Acrylic			A
35582	35592	2	1/4-20	—
35584	35594	4	1/4-20	6
35586	35596	6	1/4-20	10



ST SERIES VALVES & S SERIES APPLICATOR

ST Series valves are used with full flow dispensers where feed rate adjustment is desired at the point of lubrication. When variable operating conditions require frequent adjustment, the large, knurled knob simplifies setting the desired feed rate.

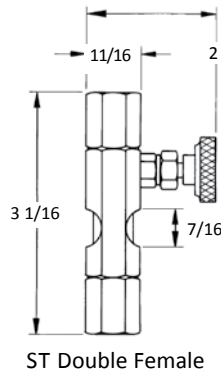


SPECIFICATIONS

Max. Operating Temp.	200°F Continuous
Oil Sight	Heavy Wall Heat Resistant Glass High Impact Strength Polycarbonate Plastic
Gasket	Buna-N
Packing Gland	Self Lubricating Buna-N
Material	Brass
Finish	Lacquered Satin Finish
Needle Value	Brass

FEATURES

- Horizontal design of needle valve minimizes contamination at the valve seat
- Double female threads simplify installation
- Heavy wall polycarbonate or heat resistant glass sights allow easy setting of the desired drip rate
- Silver brazing of all brass construction provides long life and leak proof design
- Clear lacquer finish of brass components resists corrosion



SELECTION CHART

Double Female

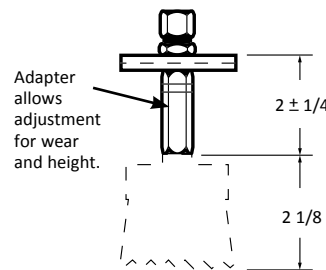
Model No.		Connection (NPT)		Sight Position
Glass	Plastic	In	Out	
32404	32408	1/4	1/4	Right Angle

S SERIES APPLICATOR BRACKETS

S series applicator brackets provide an easy way to mount Trico applicators in remote mounting applications. These brackets are used with full flow dispensers.

FEATURES

- Rigid steel extrusion, nickel plated for durable installation
- Mounting hole and 1/4 in. tubing connector simplifies installation
- Adjustable for brush wear



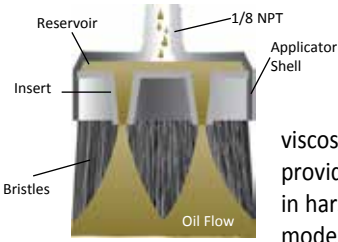
SELECTION CHART

Model No.	Gang	Mounting Hole Diameter (in.)
36024	1	17/64



APPLICATORS

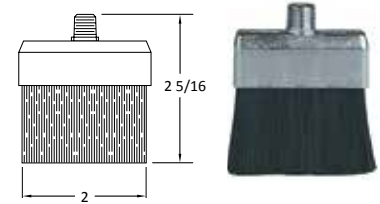
EVEN-FLO® APPLICATORS



The unique internal reservoir design of these applicators allow uniform dispensing of oil for chain lubrication. They are capable of handling a wide viscosity range of oils. Stainless steel models provide long life and excellent cleaning capability in harsh environments. Nylon and stainless steel models rated to 160°F.

SELECTION CHART (1/8 NPT connections)

Model No.	Bristle Type
36051	Nylon
36054	Stainless Steel



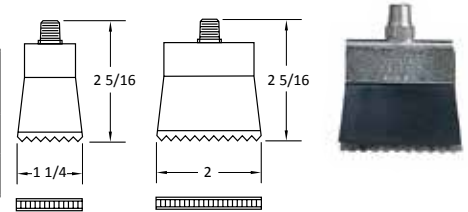
EVER-LAST® APPLICATORS



Patented Ever-Last applicators use four part construction to provide long life in the most demanding applications. Using ordinary shears, they may be trimmed to fit the exact size of chain and eliminate uneven wear of the applicator or side dripping of the lubricant. Using a Buna-N cover and felt plate, the mechanical motion of the chain movement sets up a pumping action in the applicator. Temperature rating of 200°F.

SELECTION CHART (1/8 NPT connections)

Model No.	Width (in.)
36033	1-1/4
36036	2



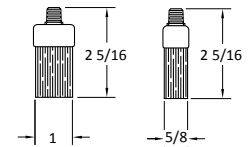
ROUND BRUSH APPLICATORS



Trico round brushes are used in applications requiring broad contact surfaces for lubricating and cleaning. They offer even oil distribution on the wearing points of chain. Stainless steel models provide long life and excellent cleaning capability in harsh environments. Nylon and stainless steel models rated to 160°F.

SELECTION CHART (1/8 NPT connections)

Model No.	Size (in.)	Bristle Type
36039	5/8	Nylon
36042	5/8	Stainless Steel
36045	1	Nylon
36048	1	Stainless Steel



ROTARY APPLICATORS

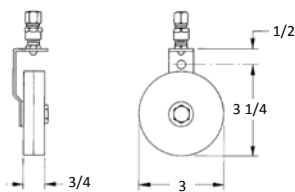


Trico rotary applicators are used to lubricate and clean chains. Available with a 3 inch nylon or stainless steel rotary brush, they provide chain driven cleaning or lubricating at the speed of the chain. They may be mounted in any orientation to the chain, but when located under the chain they are only used for cleaning. Nylon brushes rated for temperatures to 250°F and stainless steel models rated to 400°F.

REPLACEMENTS—BRUSHES

Model No.	Description
36090	3" Nylon Rotary Brush (1 pair)
36093	3" Stainless Steel Rotary Brush (1 pair)

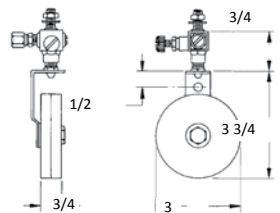
REMOTE ROTARY BRACKET FOR 1/4" TUBE



Model No.	Bristle Type
36072	Nylon
36075	Stainless Steel

ACCEPTS 1/4 O.D. TUBE
5/16 MOUNTING HOLE

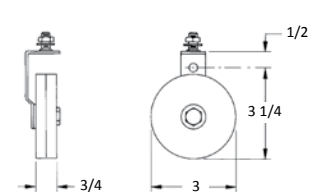
REMOTE ROTARY BRACKET/VALVE ASSEMBLY



Model No.	Bristle Type
36084	Nylon
36087	Stainless Steel

ACCEPTS 1/4 O.D. TUBE
5/16-18 MOUNTING STUD
5/16 MOUNTING HOLE

ROTARY BRACKET ASSEMBLY WITH MOUNTING STUD



Model No.	Bristle Type
36078	Nylon
36081	Stainless Steel

5/16-18 MOUNTING STUD
5/16 MOUNTING HOLE



INTRODUCTION TO GREASE LUBRICATION

GREASE BASICS

Grease is a dispersion of solid or semi solid additives, sometimes called soaps or thickeners. The purpose of grease is to lubricate moving parts while the thickener acts as a sponge, under pressure, to release the base fluid when needed.

Typically, greases are used when oil cannot adequately stay in place due to design considerations. They may also be used when it is desirable to seal out contaminants, prevent lubricant squeeze out, and resist high temperatures.

There are several methods of applying grease to the point of lubrication. The most common forms are manual, single point, and automatic/centralized lubrication. Trico offers single point lubricators.

TYPES OF SINGLE POINT LUBRICATORS (SPL)

Single point lubricators are a storage device designed to slowly dispense grease to the point of lubrication, typically a bearing, over a period of time. These devices are usually mounted in the port that a Zerk fitting occupies. They may be driven mechanically, electrically, pneumatically or by a chemical reaction process. Typically, the user sets the dispense rate to meet the requirements of the bearing based upon its size, type, speed, and orientation.

Trico offers three different types of single point grease lubricators.

- **Mechanical**—Spring loaded that drives a plunger to feed grease.
- **Electro-Chemical**—A battery operated timer activates an electrochemical cell producing expandable gas that generates pressure against a piston.
- **Electro-Mechanical**—A battery operated timer activates a motor attached through a small gearbox to drive a cam that activates a piston pump while ejecting a fixed amount of grease.



Grease lubricator installed on a blower fan

WHY USE SINGLE POINT LUBRICATORS

When selected and used properly, single point grease lubricators can solve maintenance and reliability problems. The following points outline where single point lubricators might be advisable to use:

- To prevent contamination
- An alternative to manual lubrication
- Provides a constant flow of lubricant in small volumes to achieve superior lubrication at low unit cost
- Easy to operate
- Frequent re-lubrication applications
- When there is insufficient staff to ensure proper lubrication
- Cost of automatic lubrication systems can't be justified
- Difficult access or safety hazard for manual system



Grease lubricator installed on pillow block of a dynamometer

STREAMLINER® ELECTRO-MECHANICAL GREASE DISPENSERS

Streamliner M grease dispensers are designed to ensure reliable, precise lubrication and cut lubrication costs with its advanced electro-mechanical drive. It consists of a vertical feed pump, motor and gear set, and microprocessor control system, allowing operating pressures up to 280 psi. The Streamliner M grease dispensers have a variable dispensing rate from half to 12 months. They are ideal for use in remote and multi-point applications. When used with Trico's distribution block a single unit can lubricate up to eight lubrication points (Standard Streamliner M unit only).

The grease is supplied in 125cc or 250cc grease pouches. Grease pouches and battery pack are replaceable as "Service Pack". The service pack consists of one of six standard greases.

Streamliner M-UL is similar to the standard Streamliner M unit, however it is rated to be used in hazardous locations.



- High Pressure
- Multi-point lubrication
- Refillable
- Immediate stop/start

STREAMLINER M

Variable feed rate with electro-mechanical drive

- Easy to read LCD display
- Microprocessor control
- High operating pressure of 280 psi for contamination removal and multi-point lubrication
- Multi-point lubrication capability—up to eight points (Standard Streamliner M unit only)
- Six variable dispensing rates—half, 1, 2, 3, 6, and 12 months
- Anti-vibration, break-free design
- Unit can be deactivated and adjusted as necessary
- CE and UL approved

ADJUSTMENT GUIDELINES

Below are some guidelines for bearing lubrication requirements. Requirements may vary with individual bearing types or operating conditions.

Bearing Shaft Diameter	125cc	Dispensing Equivalents	250cc	Dispensing Equivalents
121–305mm (4-¾" ~ 12")	—	—	½ mo.	16.6cc/day
105–120mm (4-¼" ~ 4-¾")	½ mo.	8.3cc/day	1 mo.	8.3cc/day
88–104mm (3-½" ~ 4-⅛")	1 mo.	4.2cc/day	2 mo.	4.2cc/day
79–87mm (3-⅜" ~ 3-½")	2 mo.	2.1cc/day	3 mo.	2.8cc/day
63–78mm (2-½" ~ 3")	3 mo.	1.4cc/day	6 mo.	1.4cc/day
49–62mm (2" ~ 2-½")	6 mo.	0.7cc/day	12 mo.	0.7cc/day
25–48mm (1" ~ 2")	12 mo.	0.3cc/day	—	—

HAZARDOUS AREA

The Streamliner M-UL is UL approved to meet the following requirements:

UL79, Power-Operated pumps for Petroleum dispensing products, Eighth Edition ANSI/ISA-12.12.01-2000, Nonincendive Electrical equipment for use in Class I and II, Division 2 and Class III, Divisions 1 and 2 Hazardous locations.

Rating	Description
Class 1	Flammable Gases, Vapors or Liquids
Division 2	Where ignitable concentrations of flammable gases, vapors and liquids are not likely to exist under normal operating conditions.
Groups – C & D	C (Ethylene), D (Propane)



STREAMLINER® ELECTRO-MECHANICAL GREASE DISPENSERS

SPECIFICATIONS

Grease Pouch Capacity*	125cc (4 oz.) and 250cc (8 oz.) (replaceable)
Power Supply*	DC 4.5 V (replaceable)
Max. Operating Pressure	800 psi (Streamliner M unit only)
Normal Operating Pressure	280 psi (Streamliner M unit) 200 psi (Streamliner M-UL unit only)
Operating Temp.	-4°F to 140°F (Streamliner M unit) 14°F to 122°F (Streamliner M-UL unit)
Dispensing Rates	1, 2, 3, 6, 12 and half month
Lube Cycle	Approximately 20 seconds/stroke
Dispensing Volume	.347 cc/cycle
Dispensing Accuracy	+/- 3% @ 68°F

*Grease pouch and battery pack sold separately as Service Pack.

HELPFUL TIP:

Trico provides a wide range of adapters, mounting brackets, tubing, and distribution blocks for remote and multi-point installations. Please see Streamliner Electro-Mechanical Accessories document on page K5.

SELECTION CHART—UNITS

125cc Reservoir	250cc Reservoir	Description	Connection
33347	33348	Streamliner M Unit	3/8" NPT
33372	33371	Streamliner M-UL Unit	3/8" NPT

Grease pouch and battery pack sold separately as Service Pack.

Streamliner MS unit also available

The MS unit has all the same features and specifications as the M unit and in addition, is capable of operating only when the equipment is running.

PART NUMBERS—MS SERIES

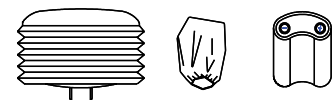
Model No.	Capacity	Units/Case
33366	250cc	Single Unit

SELECTION CHART—SERVICE PACK

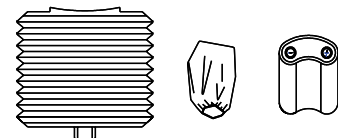
125cc Reservoir	250cc Reservoir	Grease Type	NLGI #	Thickener Type
33349	33356	Mobilgrease XHP 222	2	Lithium Complex
33350	33357	Exxon Unirex EP2	2	Lithium Complex
33351	33358	Mobilith SHC 100	2	Lithium Complex
33352	33359	Mobilgrease FM 222	2	Aluminum Complex
33353	33360	Mobilith SHC 220	2	Lithium Complex
33354	33361	Mobilith SHC PM 460	1.5	Lithium Complex

Custom grease filling is available. For specific terms and conditions please contact a Trico Customer Service Representative.

125 cc Service Pack



250 cc Service Pack



STREAMLINER® M 500CC GREASE DISPENSER

The Streamliner M family now offers a larger reservoir capacity of 500cc to meet the demand for multi-point lubrication and the lubrication of large size bearings. The larger reservoir volume minimizes labor cost associated with the more frequent grease cartridge replacement that occurs with the 125cc and 250cc units.

The grease is supplied in a customized 500cc grease pouch. The grease pouch and battery pack are replaceable as a "Service Pack". The service pack consists of one of six standard greases with either a standard alkaline battery pack or high performance lithium battery pack, depending on the requirements of the application (see battery selection guide).

The Streamliner M 500cc consists of a vertical feed pump, motor/gear set, and microprocessor control system, which delivers an operating pressure of 280 psi. The lithium battery pack allows you to achieve higher pressures which makes the unit ideal for multi-point lubrication. When used with Trico's distribution block a single unit can lubricate up to eight lubrication points.



FEATURES

- Easy to read LCD display
- Electro-mechanical driven with microprocessor control
- Eight variable dispensing rates - half, 1, 2, 4, 6, 12, 18, and 24 months
- Multi-point lubrication capability up to eight points
- Indication of grease pouch and battery replacement
- Indication of motor overloading along with date
- Indication of days remaining until servicing
- Immediate start/stop
- Auto locking mode is provided so the unit operates based on the user setting during a full period of service. It prevents a possible mode change from an accidental press of a keypad during unit operation.

SELECTION CHART—UNITS

Model No.	Description	Connection
33410	Streamliner M 500cc	3/8" NPT

Grease pouch and battery pack sold separately as Service Pack.

SELECTION CHART—SERVICE PACK

Alkaline	Lithium	Grease Type	NLGI #	Thickener Type
33412	33418	Mobilgrease XHP 222	2	Lithium Complex
33413	33419	Exxon Unirex EP2	2	Lithium Complex
33414	33420	Mobilith SHC 100	2	Lithium Complex
33415	33421	Mobilgrease FM 222	2	Aluminum Complex
33416	33422	Mobilith SHC 220	2	Lithium Complex
33417	33423	Mobilith SHC PM 460	1.5	Lithium Complex

Custom grease filling is available. For specific terms and conditions please contact a Trico Customer Service Representative.

SPECIFICATIONS

Grease Pouch Capacity	500cc (replaceable)
Power Supply	DC 4.5 V (replaceable) Alkaline Battery Lithium Battery
Max. Operating Pressure	800 psi
Normal Operating Pressure	280 psi
Operating Temperature	Alkaline Battery: 14°F to 122°F Lithium Battery: -40°F to 140°F
Dispensing Rates	Half, 1, 2, 4, 6, 12, 18, 24 months
Lube Cycle	Approximately 20 seconds/stroke

BATTERY SELECTION GUIDE

	Alkaline	Lithium
Operating Temp.	14°F to 122°F	-40°F to 140°F
Back Pressure	280 psi or less	Greater than 280 psi
Multi-Point Capability	N/A	Up to 8 points
Remote Distance	10 ft or less	Greater than 10 ft

HELPFUL TIP:

The new P/N 33410 grease dispenser utilizes a new style of grease pouch that threads directly into the pump. These part numbers are listed in the chart to the left. The new service packs are not interchangeable with P/N 33306 grease dispenser.



STREAMLINER® ELECTRO-MECHANICAL ACCESSORIES

Trico provides a wide range of adapters, mounting brackets, tubing and distribution blocks for remote and multi-point installations.

ACCESSORY ITEMS

Model No.	Description
33401	Streamliner M Model Installation Kit
33402	Streamliner M Installation Kit (2 Point)
33403	Streamliner M Installation Kit (4 Point)
33404	Streamliner M Installation Kit (6 Point)
33405	Streamliner M Installation Kit (8 Point)



DISTRIBUTION BLOCK

Model No.	Description
33381	4 outlet
33382	6 outlet
33383	8 outlet

The Distribution Block allows a single unit to lubricate up to eight lubrication points (Streamliner M and 500 cc unit only).



Streamliner M unit with a 4-outlet distribution block

STREAMLINER® DC ELECTRO-CHEMICAL GREASE DISPENSERS

The Streamliner DC automatic single point lubricator offers maintenance professionals the ability to keep equipment properly lubricated. The key to the high degree of reliability with the Streamliner DC is the innovative, fully-adjustable gas generating power source. The power source generates gas that creates a consistent pressure on a piston which gradually and continuously dispenses the lubricant contained in the chamber.

Delivery time is easily set with a simple twist of an allen key on top of the unit. The dispensing time of the Streamliner DC is variable between one and twelve months allowing complete control over the amount of lubricant being applied.

The transparent housing provides visual confirmation of the rate of delivery. Unlike opaque lubricators, one quick glance is all that is needed to see just how much lubricant is left in the cartridge.

The light weight, compact design of the Streamliner DC allows for installation in almost any place and any position, even under water.

FEATURES

- Simple to install and activate
- Powered by a patented gas generating dry cell
- Adjustable time setting from 1 to 12 months reduces inventory costs, less units to have available
- Transparent chamber allows easy visual check of lubricant level
- Sealed point of contact prevents contamination with dirt and water - submersible in any direction
- Easy adjustment of dispensing rate during operation
- Environmentally friendly
- Can be temporarily deactivated
- Custom filling with grease or oil is available
- Intrinsically safe - Class I, II, III; Division 1; Groups A, B, C, D, E, F, and G



SPECIFICATIONS

Grease Capacity	30, 60, or 125 cc
Power Generation	Hydrogen Gas Producing Dry Cells
Working Pressure	Maximum 72 PSI (5 bar)
Dispensing Quantity	0.08 – 8.3 cc/day
Operating Temperature	-4°F to 131°F (-20°C to 55°C)
Seven Standard Greases	Mobilgrease XHP 222 Exxon Unirex EP 2 Mobilith SHC 100 Mobilgrease FM 222 Mobilith SHC 220 Mobilith SHC PM 460 Mobil Polyrex EM
Thread Size	¼" NPT

SELECTION CHART

Model 30 cc	Model 60 cc	Model 125 cc	Grease Type	NLGI #	Thickener Type
33902	33922	33942	Mobilgrease XHP 222	2	Lithium Complex
33903	33923	33943	Exxon Unirex EP2	2	Lithium Complex
33904	33924	33944	Mobilith SHC 100	2	Lithium Complex
33905	33925	33945	Mobilgrease FM 222	2	Aluminum Complex
33906	33926	33946	Mobilith SHC 220	2	Lithium Complex
33907	33927	33947	Mobilith SHC PM 460	1.5	Lithium Complex
33908	33928	33948	Mobil Polyrex EM	2	Polyurea



STREAMLINER® ELECTRO-CHEMICAL GREASE DISPENSERS

Streamliner V Grease Dispensers are designed for applications where it is essential to have precise amounts of grease delivered to critical machine parts and are a cost-effective alternative to fully integrated lube systems or manual lubrication. Streamliner V Grease Dispensers have a variable dispensing rate from 1 to 12 months and are controlled by a microprocessor to ensure reliable and predictable lubricant delivery.

STREAMLINER V

Variable feed rate with electro-chemical drive

- Pre-filled with one of six standard grease types
- Microprocessor control
- Large LCD display
- Six variable dispensing rates – 1, 2, 3, 6, 12 months, and purge
- Auto purge cut-out
- Economical 125cc and 250cc reservoir capacities for fewer replacements and less disposal
- Indication of operation with green LED
- Transparent reservoir for easy viewing of grease level
- Unit can be deactivated and adjusted as necessary

SPECIFICATIONS—V SERIES

Operating Temp.	-4°F to 140°F
Max. Working Pressure	80 psi
Dispensing Rates	1, 2, 3, 6, 12 months, and purge
Grease Capacity	250cc
Thread Size	3/8" NPT
Anti-Explosive Certi Grade	Ex ia I/II B T6

SELECTION CHART

Model 125cc	Model 250cc	Grease Type	NLGI #	Thickener Type
33333	33340	Mobilgrease XHP 222	2	Lithium Complex
33334	33341	Exxon Unirex EP2	2	Lithium Complex
33335	33342	Mobilith SHC 100	2	Lithium Complex
33336	33343	Mobilgrease FM 222	2	Aluminum Complex
33337	33344	Mobilith SHC 220	2	Lithium Complex
33338	33345	Mobilith SHC PM 460	1.5	Lithium Complex

Custom grease filling is available. For specific terms and conditions please contact a Trico Customer Service Representative.



- Inert gas generation
- Economical reservoir capacity
- Immediate stop/start
- Disposable



Streamliner V installed on a blower fan

ACCESSORY ITEMS

Model No.	Description
33400	Streamliner V Installation Kit



STREAMLINER® S GREASE DISPENSER

The Streamliner S is a self-contained unit that offers worry free operation. It contains 5 different control settings, delivering the proper amount of grease to the lubrication point. The unit has a double spring design at the bottom of the grease dispenser, which pushes the grease upward into a grease intake orifice, then down a guide tube and into the lubrication point. This design provides a more uniform dispensing pressure, prevents hardening of the grease, and allows the grease dispenser to completely empty its contents.

FEATURES

- Five different control settings by simply turning the valve position indicator located on top of the grease dispenser
- Double spring design for more uniform dispensing pressure
- Clear reservoir for easy viewing of grease levels



SPECIFICATIONS

Grease Capacity	100 cc (90 grams)
Operating Temperatures	-10°F – 250°F (-23°C – 121°C)
Thread Connection	1/4" NPT
Suitable Greases	NLGI 1 - NLGI 2
Spring Force	15 psi

SELECTION CHART—UNIT

Model No.	Description
33392	Streamliner S Grease Dispenser

RECOMMENDED CONTROL SETTINGS

Bearing Shaft Diameter	Up to 2 in or 50 mm			
	Intermittent		Continuous	
Bearing Type	Shielded	Open	Shielded	Open
Regardless of RPM	1	2	3	4

Bearing Shaft Diameter	Over 2 in or 50 mm			
	Intermittent		Continuous	
Bearing Type	Shielded	Open	Shielded	Open
Under 1,000 RPM	1	2	3	4
1,000–3,000 RPM	3	3	4	4
Over 3,000 RPM	4	4	5	5

Control setting: 5 highest–1 lowest



STREAMLINER® MECHANICAL GREASE DISPENSERS



- Refillable
- Versatile

Streamliner grease dispensers apply a precise flow of grease to critical machine parts. They are a cost-effective alternative to fully integrated lube systems or manual lubrication. The grease dispensers are ideal for industries where high volumes of moisture, accelerated temperatures and contamination are present. Their simplicity in operation insures dependability and ease of service.

STREAMLINER GL-P

Mechanical – spring loaded

- Anodized aluminum base resists corrosion and works well in high vibration applications
- Clear reservoir for easy viewing of grease levels
- Each unit supplied with three different spring sizes for maximum versatility

SPECIFICATIONS—GL-P SERIES

Max. Operating Temp.	212°F
Spring Force	Light (5 psi), medium (10 psi), and heavy (15 psi) included with each model
Grease Capacity	2-1/2 ounces
Thread Size	1/8", 1/4", 3/8", and 1/2" NPT
Suitable Greases	NLGI 0–NLGI 3

PART NUMBERS—GL-P SERIES

Model No.	NPT	Spring Force
33301	1/8	Light, medium, and heavy spring included with each model
33302	1/4	
33303	3/8	
33304	1/2	



GREASE METER

It is difficult to grease a bearing with the right amount of grease with a grease gun. Most bearings are often given either too much or too little grease causing a shortening of bearing life and often results in costly breakdowns and stoppages. Trico's Grease Meter measures the amount of grease dispensed from the grease gun to the equipment bearing. A simple push of a button will set the meter to zero and the metering can be started. The amount of grease dispensed is displayed on a digital screen and can be expressed in cubic centimeters, grams, ounces, or fluid ounces. With Trico's Grease Meter it is possible to grease exactly to bearing manufacturer's recommendations. This will increase the life of the bearing and reduce the number of stoppages.

FEATURES

- Digital screen displays grease dispensed in cubic centimeters, grams, ounces, or fluid ounces
- Backlit LCD displays large easy-to-read digits, including low battery indication
- Handles up to 10,000 psi working pressure
- Unit can be calibrated for different greases
- Precise measurement and control of grease delivery
- Small, compact and lightweight design (.66 lb)
- Corrosion free aluminum housing

SPECIFICATIONS

Housing Material	Anodized Aluminum
Seals	Buna-N
Working Pressure	Max 10,000 psi (700 bar)
Flow	Max 1000 cm ³ /min
Accuracy	+/- 3% up to 4,300 psi (300 bar)
Display	Lit LCD (4 digits / 9 mm)
Battery Type	1.5 V LR1 Alkaline (2x)
Suitable Greases	Up to NLGI 2
Auto Shut Off	1 min
Weight	.66 lb (.3 kg)
Connections	1/8" NPT

SELECTION CHART

Model No.	Description
39350	Grease Meter



Grease meter being used with Spectrum Grease Identification Products to ensure the right grease goes into the right piece of equipment.



Grease meter is easily installed onto a grease gun.

SELECTION CHART—GREASE GUNS

Model No.	Description
36680	Lever Grease Gun—Heavy Duty
36681	Pistol Grip Grease Gun—Heavy Duty
36682	Air Operated Pistol Grip Grease Gun
36683	12" Flexible Grease Gun Hose



INTRODUCTION TO CENTRAL LUBRICATION



SINGLE LINE RESISTANCE SYSTEMS

Trico central lubrication products are commonly known as Single Line Resistance Systems. They are used throughout industry where reliable oil lubrication is required. The basic principles of these systems are:

- Oil lubrication
- Pump operation to deliver the oil to the system
- Individual control of oil lubrication amounts at each lubrication point
- Meter and control units create resistance to flow to apportion oil delivery
- Total loss or re-circulating systems

POSITIVE DISPLACEMENT INJECTION SYSTEMS

Trico offers a line of products that complement the single line resistance systems. Instead of using meter or control units, a piston dispenses a pre-set amount of oil at each cycle of the pump. These systems do require that different pumps be used than with single line resistance systems. All fittings and tubings are interchangeable between the two systems.

Common applications are shown below. These are found on punch presses, milling machines, printing presses, injection molding machines, textile machinery, and all types of machine tools.



Ball Bearings



Plain Bearings



Flat Slides



Cylindrical Slides



Ball Bearing Slides



Cams



Gears



Chains

BASIC TYPES OF SYSTEMS

MANUAL PUMPS

These single-shot systems use a manually actuated pump for applications where infrequent lubrication is required.

FEATURES

- Low cost, simplified installation and operation
- Manual and spring discharge pumps
- Reservoir capacities to 450 cc
- Applications with less than 50 points
- Used with meter units
- Total loss systems



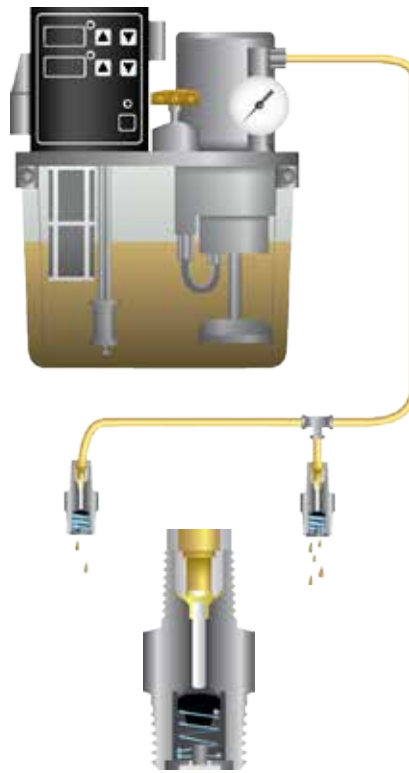
Manual or single-shot pumps use **meter units** to apportion the amount of oil at each lubrication point.

AUTOMATIC CYCLIC PUMPS

For those who need automatic lubrication on an intermittent basis, a cyclic system is required. Cost for these systems are economical and vary based on the type of control used to regulate the lube interval and capacity of the reservoir.

FEATURES

- Spring discharge and gear pumps
- Adjustable interval times between lubrication
- Adjustable oil volume outputs
- Reservoir capacities up to 20 liters
- Applications with up to 50 lubrication points
- Used with meter units
- Total loss systems



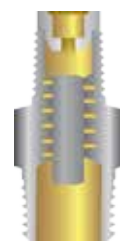
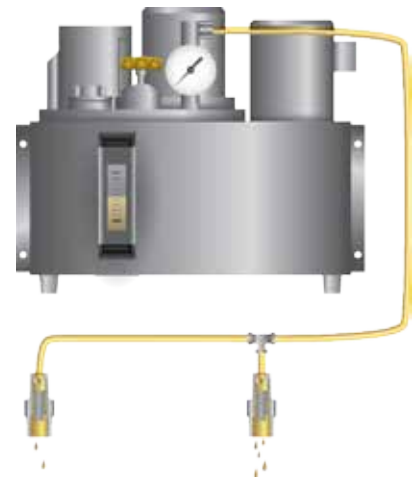
Automatic Cyclic pumps use **meter units** to apportion the amount of oil at each lubrication point.

CONTINUOUS PUMPS

For large lubrication requirements a continuous system should be used. These systems are commonly used on equipment with a high number of lubrication points.

FEATURES

- Gear pump design
- Constant oil volume outputs
- Reservoir capacities up to 20 liters
- Applications with up to 200 lubrication points
- Used with control units
- Total loss systems or re-circulating systems



Continuous pumps use **control units** to apportion the amount of oil at each lubrication point.

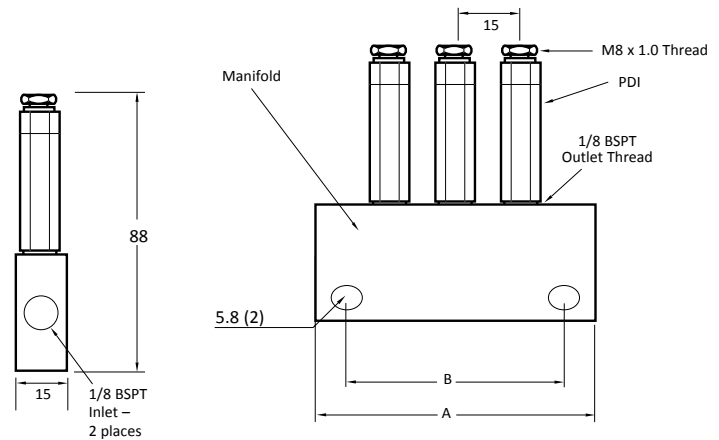
POSITIVE DISPLACEMENT INJECTORS

Positive Displacement Injectors (PDI's) are an excellent means of providing oil lubrication to machinery. Using a piston principle, the PDI will lubricate individual points with specific amounts of oil. There are 6 output sizes to choose from: 0.06, 0.10, 0.16, 0.20, 0.30, and 0.50 cc's per cycle. A typical system will include a pump, any number of PDI's, and the necessary tubing and fittings.

At the start of the lubrication cycle, the PE-34 or PE-44 Series pump builds pressure. Upon pressure build-up, the PDI's deliver the pre-set amount of oil. At the end of the lubrication cycle, a pressure unloading valve opens to return line pressure to 0 PSI. This allows the PDI's to reset for the next cycle.

HOW TO ORDER

1. For each lubrication point, select the appropriate Positive Displacement Injector (PDI) based on the oil output per cycle.
2. Select the manifolds required for mounting that simplify installation.
3. Select either a PE-34 Series Automatic Cyclic pump with built-in cycle controls, or a PE-44 Series standard pump that uses external controls for the lubrication cycle. A choice of reservoir capacities is available for both pumps.



(Note: All dimensions are mm.)

PDI SELECTION CHART

Model No.	Output Volume (cc/cycle)
PDI-06	0.06
PDI-10	0.10
PDI-16	0.16
PDI-20	0.20
PDI-30	0.30
PDI-50	0.50

MANIFOLDS SELECTION CHART

Model No.	No. of Outlets	Dimensions (mm)	
		A	B
PDM-42	2	47	37
PDM-43	3	62	52
PDM-44	4	77	67
PDM-45	5	92	82
PDM-46	6	107	97

PDI SPECIFICATIONS

Inlet Thread Size	1/8 BSPT
Outlet Thread Size	M8 x 1.0
Operating Pressure	200 PSI
Pump Required	PE-34 or PE-44
Oil Viscosity	30-250 CST (150-1250 SUS)

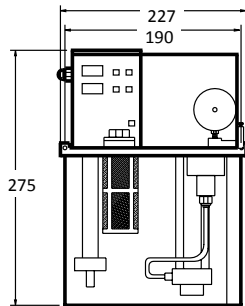
MANIFOLD SPECIFICATIONS

Connection Port	Thread Size	No. of Ports
Inlet	1/8 BSPT	2
Outlet	1/8 BSPT	2 to 6

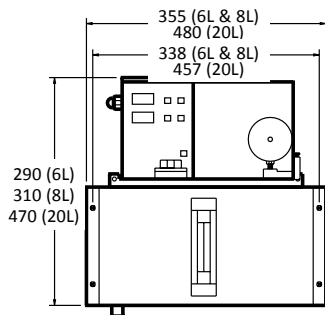
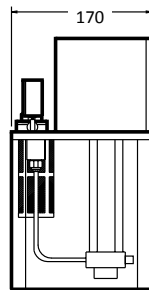


PUMP SELECTION CHART

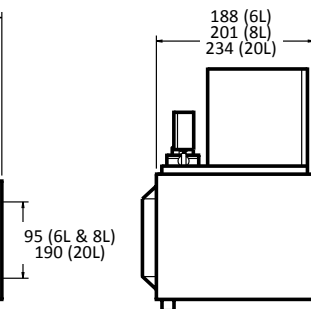
Model No.	Pump Type	Reservoir Capacity (liters)	Oil Delivery Time	Interval Time Between Cycles
PE-3403	Auto-Cyclic with Integral Digital Controls	3	1-999 sec	1-999 minutes
PE-3406		6		
PE-3408		8		
PE-3420		20		
PE-4403	Standard Pump for User Installed Controls	3	User Installed	User Installed
PE-4406		6		
PE-4408		8		
PE-4420		20		



3 Liter Reservoir



(Note: All dimensions are mm.)
6, 8 and 20 Liter Reservoirs



PUMP SPECIFICATIONS

PE-34 and PE-44 Series	
Motor Voltage	110-1-50/60 Standard 220-1-50/60 Optional
Pump Type	Gear Pump
Maximum Pressure	200 PSI
Maximum Flow	100 cc/min
Output Connection	5/16-24 (f)
Seals	Buna-N
Oil Viscosity	30-250 CST (150-1250 SUS)

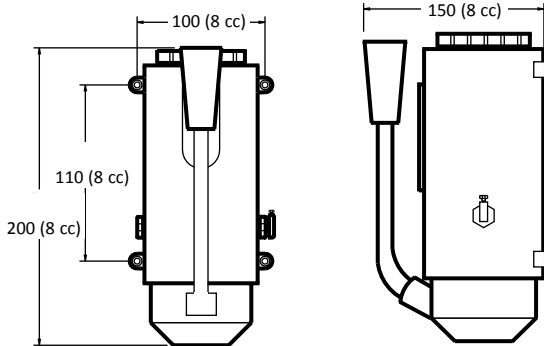


PM-10 & 20 SERIES MANUAL CYCLIC PUMPS

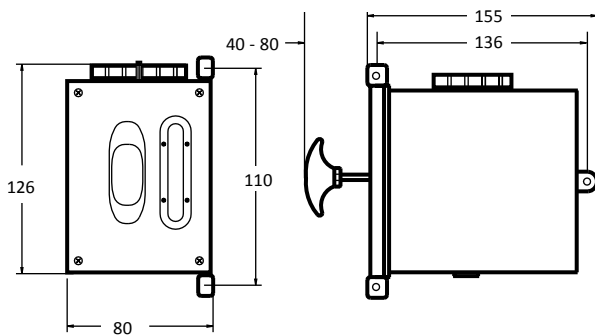
PM series pumps are used in applications where a fixed output of lubricant is desired. With the PM-10 series, the leverage of the pump handle enables the unit to deliver a higher pressure than most models, providing the ability to lubricate points having some back pressure. With the PM-20 series, lubricant output takes place upon release of the handle using spring discharge to assure the correct amount of lubricant is applied. These pumps are commonly used with meter units in single or multiple point applications. Common applications include punch presses and milling machines where infrequent but reliable lubrication is required.

FEATURES

- Aluminum die cast reservoir provides long life
- Outputs cc/stroke
- Sight gauge provides liquid level observation
- Large fill port for easy adding of lubricant
- Convenient drop-in filter in fill port keeps oil clean



PM-10 Series



PM-20 Series

(Note: All dimensions are mm.)



SPECIFICATIONS

Reservoir Material	Cast Aluminum
Pump Type	PM-10 Series, Manual Piston Pump PM-20 Series, Spring Discharge Piston
Output Connection	5/16-24
Seals	Buna-N
Operating Temp.	32–120° F

SELECTION CHART

Model No.	Pump Type	Output cc/stroke	Pressure (PSI)	Capacity (cc)
PM-1000-08	Vertical Mount	8	200	450
PM-2000-L	Horizontal Mount	8	70 (average)	550
PM-2000-R	Horizontal Mount	8	70 (average)	550

ACCESSORIES

Meter units, and fittings and accessories are available.



PE-10 & 12 SERIES AUTOMATIC CYCLIC PUMPS

In heavy duty applications requiring a timed delivery of lubricant, the PE 10 and 12 series automatic cyclic pumps are used. These durable pumps provide long life and trouble-free service. With variable lubricant outputs and a choice of cycle times, they offer excellent versatility in many applications. An adjustment screw with a calibrated rod simplifies setting the lubricant delivery output. These pumps are used with meter units in multiple point applications. Common applications include punch presses, milling machines, and other machine tools.

FEATURES

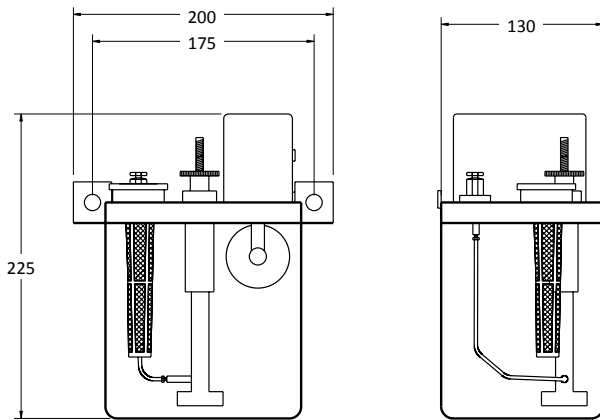
- Transparent 2 liter reservoir simplifies viewing oil level
- PE 12 series provided with low level switch to signal when lubricant level is low
- Adjustable output range of 3 to 6 cc/cycle, or 3 to 120 cc/hour
- Large fill plug simplifies adding or changing lubricant
- Convenient drop-in filter in fill port keeps oil clean



PE-1002-05

HELPFUL TIP:

For assistance on designing a central lubrication system, visit our website at www.tricocorp.com/technical/central-lub-worksheet.aspx.



(Note: All dimensions are mm.)

SPECIFICATIONS

Reservoir Capacity	2 Liters
Motor Voltage	110-1-50/60
Pump Type	Spring Discharge Piston Pump
Maximum Pressure	40 PSI
Output Connection	5/16-24 (f)
Seals	Buna-N
Operating Temp.	32-120° F

SELECTION CHART

Model No.	Output (cc/cycle)	Interval Time Between Cycles (min.)	Minimum Output (cc/hour)	Maximum Output (cc/hour)	Low Level Switch
PE-1002-03	Adjustable 3-6	3	60	120	No
PE-1002-05		5	36	72	
PE-1002-10		10	18	36	
PE-1002-15		15	12	24	
PE-1002-30		30	6	12	
PE-1002-60		60	3	6	
PE-1202-03		Yes	3	60	120
PE-1202-05			5	36	72
PE-1202-10			10	18	36
PE-1202-15			15	12	24
PE-1202-30			30	6	12
PE-1202-60			60	3	6

Add "-220" to model number for 220 volt motor.

ACCESSORIES

Meter units, and fittings and accessories are available.



PE-20, 22, & 24 SERIES AUTOMATIC CYCLIC PUMPS



The PE-20 series pumps are designed for automatic cyclic systems with fewer than 50 points. These pumps are ideal for punch presses and machine tools where small and consistent amounts of lubricant are required. These pumps are used with meter units in multiple point applications.

SPECIFICATIONS

Reservoir Capacity	2 Liters
Motor Voltage	110-1-50/60 Standard 220-1-50/60 Optional
Pump Type	Gear Pump
Maximum Pressure	PE-20, 22 Series: 100 PSI PE-24 Series: 70 PSI
Output Connection	5/16-24 (f)
Seals	Buna-N
Operating Temp.	32-120° F

SELECTION CHART

Model No.	Output	Interval Time Between Cycles	Minimum Output (cc/hour)	Low Level Switch	Low Level Alarm and Pressure Gauge
PE-2002-06	6 cc/cycle	0 min. to 60 min.	6	Yes	No
PE-2002-15	15 cc/cycle		15		
PE-2202-06	6 cc/cycle		6		
PE-2202-15	15 cc/cycle		15		
PE-2402	3.33 cc/sec. Variable delivery time of 1-180 sec.	1 min. to 180 min.	1.1		Yes

Add "-220" to model number for 220 volt motor.

FEATURES

PE-20 Series

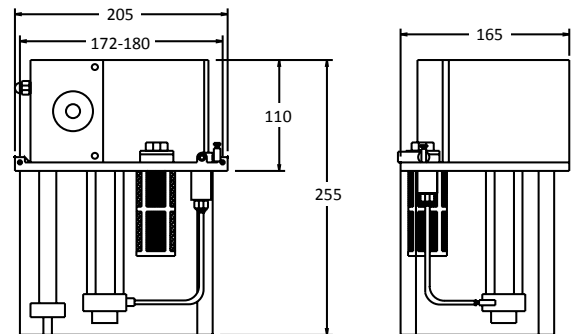
- Adjustable interval time between lubrication cycles of up to 60 minutes
- Heavy duty plastic reservoir simplifies oil level viewing
- Choice of 6 cc or 15 cc output per cycle
- Low level switch with alarm

PE-22 Series

- Adjustable interval time between lubrication cycles of up to 60 minutes
- Heavy duty plastic reservoir simplifies oil level viewing
- Choice of 6 cc or 15 cc output per cycle
- Low level switch with alarm
- Pressure gauge

PE-24 Series

- Adjustable interval time between lubrication cycles of up to 180 minutes
- Heavy duty plastic reservoir simplifies oil level viewing
- Adjustable output cycle time of 1-180 sec., flow rate of 200 cc/min
- Low level switch with alarm
- Pressure gauge



(Note: All dimensions are mm.)

ACCESSORIES Meter units, and fittings and accessories are available.



PE-30 & PE-32 SERIES AUTOMATIC CYCLIC PUMPS

FEATURES

PE-30 & PE-32 Series

- Low level switch with alarm
- Pressure gauge
- Heavy duty plastic reservoir (3 liter) simplifies oil level viewing. Metal reservoirs available in 6, 8, and 20 liters for larger systems.

PE-30 Series

- Adjustable output cycle time of 1-180 seconds, flow rate of 200 cc/min
- Adjustable interval time between lubrication cycles of 3-999 minutes

PE-32 Series

- Adjustable output cycle time of 1-999 seconds, flow rate of 250 cc/min
- Adjustable interval time between lubrication cycles of 3-999 minutes
- Pressure adjustment valve
- Pressure switch, with reset button, shuts down pump if system pressure drops below set level, protecting against line or component failure



PE-3003

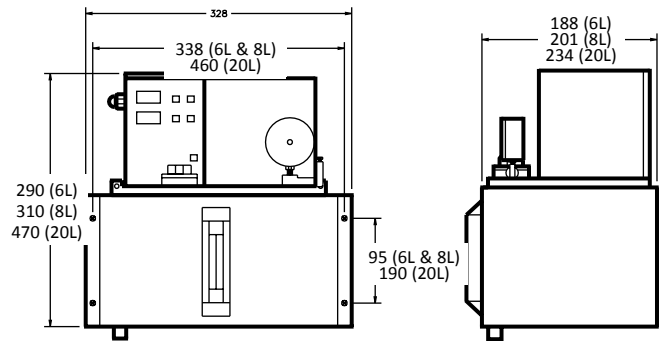


PE-3203

The PE-30 & PE-32 series are the most versatile automatic cyclic pumps available. Both the lubricant dispensing time, and the time interval between cycles is digitally controlled. With reservoir sizes up to 20 liters, these pumps can handle systems with up to 100 lubrication points. Applications include large printing presses and injection molding machines. These pumps are used with meter units in multiple point applications.

SPECIFICATIONS

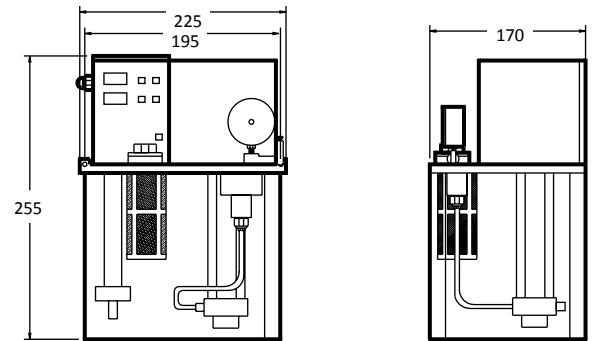
Reservoir Capacity	3 Liter Plastic 6, 8, and 20 Liter Steel
Motor Voltage	110-1-50/60 Standard 220-1-50/60 Optional
Pump Type	Gear Pump
Maximum Pressure	100 PSI - PE 30 140 PSI - PE 32
Output Connection	5/16-24 (f)
Seals	Buna-N
Operating Temp.	32-120° F



6, 8 and 20 Liter Reservoirs

SELECTION CHART

Model No.	Reservoir Capacity (liters)	Reservoir Material	Output	Intrval Time* Between Cycles	Minimum Output (cc/hour)
PE-3003	3	Plastic	3.33 cc/sec. Variable delivery time of 1-180 sec.	3-999 minutes	.2
PE-3006	6	Metal			
PE-3008	8				
PE-3020	20				
PE-3203	3	Plastic	4.17 cc/sec. Variable delivery time of 1-999 sec.		
PE-3206	6	Metal			
PE-3208	8				
PE-3220	20				



3 Liter Reservoir
(Note: All dimensions are mm.)

ACCESSORIES

Meter units, and fittings and accessories are available.

Add "-220" to model number for 220 volt motor.



PE-40 & PE-50 SERIES CONTINUOUS SYSTEM PUMPS



PE-4003



PE-5003

Trico's continuous system pumps are designed for applications where lubrication of critical components is needed on a continual basis, rather than on a timed basis. Using continuous system control units, these pumps provide lubricant at flow rates of 250 cc/min. Common applications include injection molding, printing presses, punch presses, and milling machines.

FEATURES

PE-40 and PE-50 Series

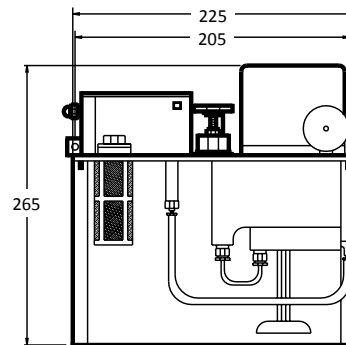
- Standard float switch provides signal when lubricant level is low
- Easy view plastic reservoir on 3 liter models, steel reservoir with sight gauge on 6, 8 and 20 liter reservoirs
- Return to tank port available on 6, 8 and 20 liter models for returning unused oil to reservoir
- Provided with pressure gauge as standard
- Safety relief valve assures reliable performance

PE-40 Series

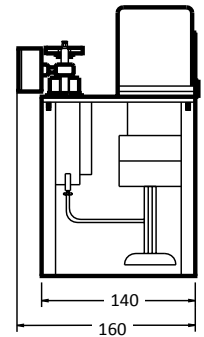
- Pressure switch, with reset button, shuts down pump if system pressure drops below set level, protecting against line or component failure

SPECIFICATIONS

Reservoir Capacity	3 Liter Plastic 6, 8, and 20 Liter Steel
Motor Voltage	110-1-50/60 Standard 220-1-50/60 Optional
Pump Type	Gear Pump
Maximum Pressure	140 PSI
Output Connection	5/16-24 (f)
Seals	Buna-N
Operating Temp.	32-120° F

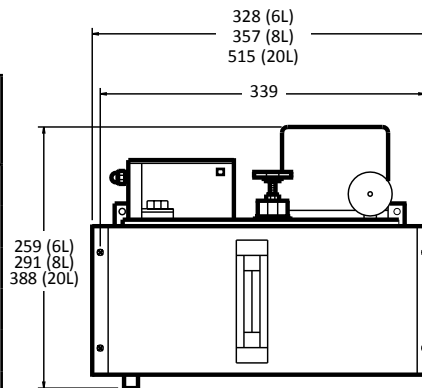


PE-40 and PE-50
3 Liter Reservoirs

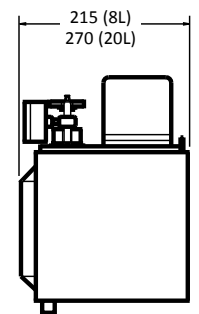


SELECTION CHART

Model No. (standard)	Model No. (with return to tank port)	Pressure Switch	Reservoir Capacity (liters)	Reservoir Material	Output Volume (cc/min)
PE-4003	—	Yes	3	Plastic	250
PE-4006	PE-4206		6	Metal	
PE-4008	PE-4208		8		
PE-4020	PE-4220		20		
PE-5003	—	No	3	Plastic	
PE-5006	PE-5206		6	Metal	
PE-5008	PE-5208		8		
PE-5020	PE-5220		20		



PE-40 and PE-50
6, 8 and 20 Liter Reservoirs
(Note: All dimensions are mm.)

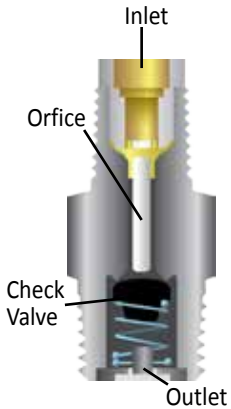


Add "-220" to model number for 220 volt motor.

*Refer to Accessories document for accessories on return to tank port pumps.



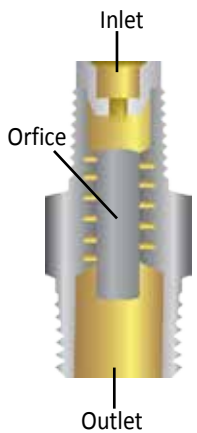
METER & CONTROL UNITS



Meter units are used with all cyclic system electric and manual pumps to provide precise control of the lubricant to each lubrication point. A spring loaded check valve keeps air from entering the system when lubricant is not being supplied to the meter unit.

METER UNITS

Flow Rate	5/16-24 x 5/16-24	5/16-24 x 1/8 NPT	1/8 NPT x 1/8 NPT	M8 x 1.0 x M8 x 1.0	M8 x 1.0 x 1/8 BSPT	1/8 BSPT x 1/8 BSPT
3/0	DSM-3/0	DCM-3/0	DTM-3/0	—	—	—
00	DSM-00	DCM-00	DTM-00	DSM-00M	DCM-00M	DTM-00M
0	DSM-0	DCM-0	DTM-0	DSM-0M	DCM-0M	DTM-0M
1	DSM-1	DCM-1	DTM-1	DSM-1M	DCM-1M	DTM-1M
2	DSM-2	DCM-2	DTM-2	DSM-2M	DCM-2M	DTM-2M
3	DSM-3	DCM-3	DTM-3	DSM-3M	DCM-3M	DTM-3M
4	DSM-4	DCM-4	DTM-4	DSM-4M	DCM-4M	DTM-4M
5	DSM-5	DCM-5	DTM-5	DSM-5M	DCM-5M	DTM-5M



Control units are used with all continuous system electric pumps to provide precise control of the lubricant to each lubrication point. Because pump flow is continuous, an internal check valve is not required.

CONTROL UNITS

Flow Rate	5/16-24 x 5/16-24	5/16-24 x 1/8 NPT	1/8 NPT x 1/8 NPT	M8 x 1.0 x M8 x 1.0	M8 x 1.0 x 1/8 BSPT	1/8 BSPT x 1/8 BSPT
5/0	—	DCC-5/0	DTC-5/0	—	—	—
4/0	DSC-4/0	DCC-4/0	DTC-4/0	—	—	—
3/0	DSC-3/0	DCC-3/0	DTC-3/0	—	—	—
00	DSC-00	DCC-00	—	—	—	—
0	DSC-0	DCC-0	DTC-0	—	—	—
1	DSC-1	DCC-1	DTC-1	DSM-1M	—	DTM-1M
2	DSC-2	DCC-2	DTC-2	DSM-2M	—	DTM-2M
3	—	—	DTC-3	DSM-3M	—	—
4	DSC-4	DCC-4	—	—	—	—
5	DSC-5	—	DTC-5	—	DCM-5M	—

FLOW RATE CHART FOR METER AND CONTROL UNITS

Flow Rate	Relative Flow Delivery	Typical System Type
5/0	1	Continuous loss
4/0	2	Continuous loss
3/0	4	Continuous loss/Cyclic
00	8	Continuous loss/Cyclic
0	16	Continuous loss/Cyclic
1	32	Cyclic/Continuous re-circulating
2	64	Cyclic/Continuous re-circulating
3	128	Cyclic/Continuous re-circulating
4	256	Continuous re-circulating
5	512	Continuous re-circulating

METER AND CONTROL UNITS

Trico offers 8 different flow rates for meter units (3/0–5) and 10 for control units (5/0–5). These units are precisely manufactured to accurately apportion oil at each point. To the left is a chart that displays recommended flow rates for different types of systems.

The relative flow delivery indicates the difference in the flow rates of the meter and control rates. The smallest flow rate is “5/0” and the highest flow rate is “5”. Each meter and control unit will allow approximately twice as much flow as the next smaller size, within a lubrication system.



FITTINGS

FITTINGS

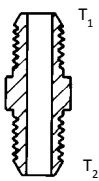
Illustration	New Model No.	T1	T2
 <p>Male Thread Connector</p>	FC-1002	5/16-24	5/16-24
	FC-1008	5/16-24	1/8 NPT
	FC-1000	1/8 NPT	1/8 NPT
	FC-1003	1/8 NPT	3/8-24
	FC-1004	1/8 NPT	7/16-24
	FC-1005	1/4 NPT	1/8 NPT
	FC-1006	1/4 NPT	7/16-24
	FC-1007	1/4-28 Zerk	1/4-28 Zerk
	FC-1002M	M8 x 1.0	M8 x 1.0
	FC-1000M	1/8 BSPT	1/8 BSPT
	FC-1014	1/8 BSPT	1/8 NPT
	FC-1015	M8 x 1.0	1/8 NPT
	FC-1010M	1/4 BSPT	1/4 BSPT
FC-1017	1/8 BSPT	5/16-24	

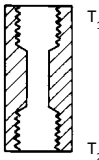
Illustration	New Model No.	T1	T2
 <p>Female Thread Connector</p>	FC-1009	5/16-24	5/16-24
	FC-1012	5/16-24	1/8 NPT
	FC-1018	1/8 NPT	1/8 NPT
	FC-1009M	M8 x 1.0	M8 x 1.0
	FC-1013M	M10 x 1.0	M10 x 1.0
	FC-1012M	M8 x 1.0	1/8 BSPT
	FC-1011M	M10 x 1.0	1/8 BSPT
	FC-1014M	M14 x 1.5	M14 x 1.5

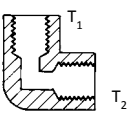
Illustration	Model No.	T1	T2
 <p>90° Elbow</p>	FE-1005	5/16-24	5/16-24
	FE-1000	5/16-24	1/8 NPT
	FE-1012	1/8 NPT	1/8 NPT
	FE-1000M	M8 x 1.0	M8 x 1.0


Illustration	Model No.	T1	T2
 <p>45° Street Elbow</p>	FE-1007	1/8 NPT	1/8 NPT
	FE-1013M	1/8 BSPT	1/8 BSPT

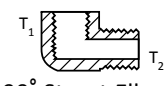
Illustration	Model No.	T1	T2
 <p>90° Street Elbow</p>	FE-1007M	M8 x 1.0	1/8 BSPT
	FE-1011M	M8 x 1.0	M8 x 1.0
	FE-1010M	1/8 NPT	1/8 BSPT

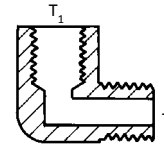
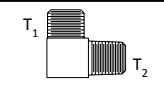
Illustration	Model No.	T1	T2
 <p>90° Street Elbow</p>	FE-1002	5/16-24	1/8 NPT
	FE-1006	1/8 NPT	1/8 NPT
	FE-1009	1/8 NPT	1/4-28 Zerk
	FE-1004M	M8 x 1.0	1/8 BSPT
	FE-1003M	M10 x 1.0	1/8 BSPT
	FE-1014M	1/8 BSPT	1/8 BSPT
	FE-1005M	M8 x 1.0	1/4 BSPT

Illustration	Model No.	T1	T2
 <p>90° Elbow</p>	FE-1015	1/8 NPT	3/8-24
	FE-1016	1/8 NPT	7/16-24
	FE-1017	1/4 NPT	7/16-24

SWIVEL FITTINGS

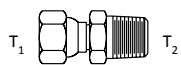
Illustration	Model No.	T1	T2
 <p>Swivel Adapter (male thread)</p>	FM-2004	1/4 NPSM	1/8 NPT
	FM-2005	1/4 NPSM	1/4 NPT


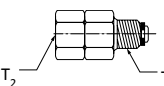
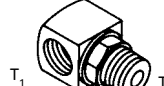
Illustration	Model No.	T1	T2
 <p>Swivel Adapter (Female thread)</p>	FE-2006	1/8 NPSM	1/8 NPT
	FE-2007	1/4 NPSM	1/4 NPT
	FE-2008	3/8 NPSM	3/8 NPT

Illustration	Model No.	T1	T2
	FM-2001M	M8 x 1.0	1/8 BSPT
	FM-2002M	1/8 BSPT	1/8 BSPT
	FM-2000	1/8 NPT	1/8 NPT
	FM-2000M	1/8 BSPT	1/8 BSPT



FITTINGS

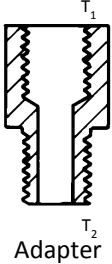
Illustration	New Model No.	T1	T2
	FA-1007	5/16-24	1/8 NPT
	FA-1008	1/8 NPT	1/8 NPT
	FA-1000	1/4 NPT	1/8 NPT
	FA-1001	5/16-24	5/16-24
	FA-1009	5/16-24	1/4-28 Zerk
	FA-1003	3/8-24	1/8 NPT
	FA-1005	1/8 NPT	5/16-24
	FA-1004	1/8 NPT	1/4-28 Zerk
	FA-1023	5/16-24	1/8 BSPT
	FA-1024	1/8 NPT	M6 x 1.0
	FA-1025	1/8 NPT	M8 x 1.25
	FA-1026	1/8 NPT	M10 x 1.5
	FA-1007M	M8 x 1.0	1/8 BSPT
	FA-1006M	M10 x 1.0	1/8 BSPT
	FA-1013M	M8 x 1.0	1/4 BSPT
	FA-1015M	1/8 BSPT	M10 x 1.0
	FA-1014M	1/8 BSPT	M8 x 1.0
	FA-1011M	M10 x 1.0	M8 x 1.0
	FA-1010M	M10 x 1.0	PT 1/4
	FA-1017M	M8 x 1.0	M6 x 1.0
FA-1023M	M8 x 1.0	M10 x 1.0	
FA-1012M	M10 x 1.0	M10 x 1.0	
FA-1017	1/8 BSPT	1/8 NPT	
FA-1018	M8 x 1.0	1/8 NPT	
FA-1020	5/16-24	M8 x 1.0	
FA-1021	M8 x 1.0	5/16-24	
FA-1022	1/8 NPT	1/8 BSPT	

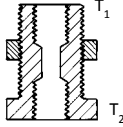
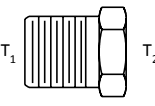
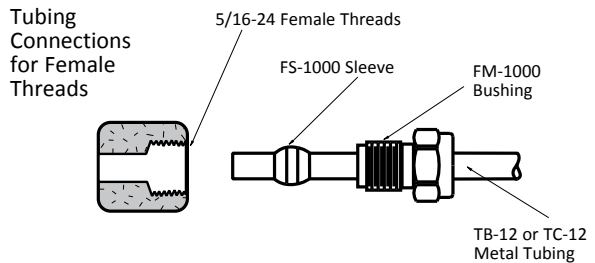
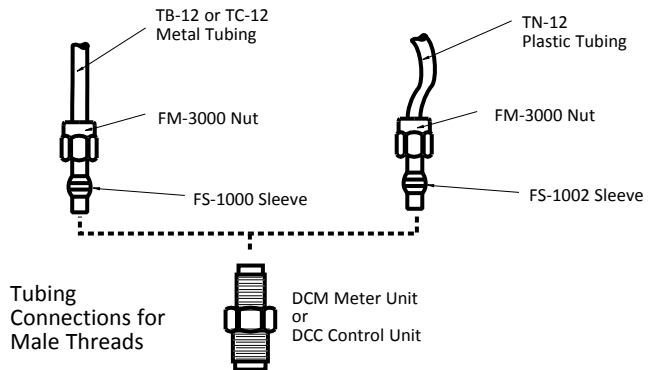




Illustration	Model No.	T1	T1
	FB-1002	5/16-24	5/16-24
	FB-1000	5/16-24	1/8 NPT
	FB-1002M	M8 x 1.0	M8 x 1.0
	FB-1003M	M10 x 1.0	M10 x 1.0
	FB-1000M	M8 x 1.0	1/8 BSPT
	FB-1001M	M10 x 1.0	1/8 BSPT


Illustration	Model No.	T1	T2
	FM-1003	3/8 NPT	1/8 NPT
	FM-1004	3/8 NPT	1/4 NPT
	FM-1005	1/2 NPT	1/8 NPT
	FM-1006	1/2 NPT	1/4 NPT
	FM-1007	1/2 NPT	3/8 NPT
	FM-1008	3/4 NPT	1/4 NPT



COMPRESSION FITTINGS

Illustration	Description	Model No.	Size	Model No.	Size
	5/16 Hex Bushing	FM-1000	5/16-24	FM-1001M	M8 x 1.0
	Nut	FM-3000		FM-3000M	M8 x 1.0
	Metal Sleeve	FS-1000	5/32 (4mm)	FS-1004M	6 mm
	Nylon Half-Sleeve	FS-1002		-	-

TUBING - 12 FOOT LENGTHS

Illustration	Material	Model No.	Tube Size	Model No.	Tube Size
	Copper	TC-12	5/32 (4mm)	TC6-12M	6mm
	Nylon	TN-12		TN6-12M	



FITTINGS & HOSES

JUNCTIONS









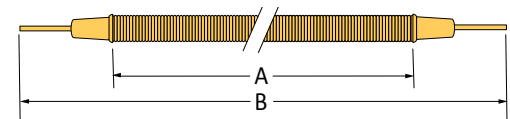
Illustration	No. of Ports	Inch Threads		Metric Threads	
		Model No.	Thread Size	Metric Model No.	Thread Size
	2	J-02	5/16-24	J-02M	MB x 1.0
	3	J-03		J-03M	
	4	J-04		J-04M	
	4	JS-04		JS-04M	
	5	JS-05		JS-05M	
	6	JS-06		JS-06M	
	7	JS-07		JS-07M	
	8	JS-08		JS-08M	
	9	-		JS-09M	
	10	JS-10		JS-10M	
	4	JD-04	-		
	6	JD-06	-		
	8	JD-08	JD-08M		
	10	JD-10	-		
	12	JD-12	JD-12M		
	3	JH-03	1/8 NPT (T ₁) x 5/16-24 (T ₂)	JH-03M	1/8 BSPT (T ₁) x M8 x 1.0 (T ₂)
	4	JH-0402		JH-0402M	




Illustration	Model No.	Thread
	FM-5000	1/8 NPT
	FM-5001	1/4 NPT

HOSES


Model No.	Diameter	Dimensions(in.)	
		A	B
H-406	5/32 (4 mm)	6	8
H-412		12	14
H-424		24	26
H-436		36	38
H-448		48	50
H-460		60	62
H-612	6 mm Diameter Hose	12	14
H-624		24	26
H-636		36	38
H-648		48	50




PLUGS

Illustration	Inch Threads	
	Model No.	Size
	FP-1003	5/16-24
	FP-1002	5/16-24
	FP-1001	1/8 NPT


REPLACEMENT STEEL RESERVOIRS

	6 Liter	8 Liter	20 Liter
	MR-1006	MR-1008	MR-1020
MR-2006 with return to tank port	MR-2008 with return to tank port	MR-2020 with return to tank port	





TUBING CLIPS

Illustration	New Model No.	Tube Size
	FT-1001M	5/32 (4mm)
1	FT-1004M	
2	FT-1006M	
3	FT-1003M	6mm
1	FT-1005M	
2		

PRESSURE GAUGES

Illustration	Model No.	Connection Thread	Pressure Range	Model No.	Connection Thread	Pressure Range
	MG-1000	1/8 BSPT Rear Mount	0-15 Bar	MG-1002	1/8 BSPT Bottom Mount	0-15 Bar
	MG-1001		0-35 Bar	MG-1003		0-35 Bar

CHECK VALVES - 5 PSI

Illustration	Flow Direction Towards	Inch Threads			Metric Threads		
		Model No.	Thread Size (T1)	Thread Size (T2)	Metric Model No.	Thread Size (T1)	Thread Size (T2)
	T2	FV-1001	1/8 NPT	5/16-24	FV-1006M	1/8 BSPT	M8 x 1.0
					FV-1007M	1/8 BSPT	M10 x 1.0
	T1	FV-1000	1/8 NPT	5/16-24	FV-1004M	1/8 BSPT	M8 x 1.0
					FV-1003M	1/8 BSPT	M10 x 1.0
	T1	FV-1002	1/8 NPT	5/16-24	FV-1002M	1/8 BSPT	M8 x 1.0
					FV-1005M	1/8 BSPT	M10 x 1.0
	T2	FV-1008	1/8 NPT	5/16-24	FV-1008M	1/8 BSPT	M8 x 1.0
					FV-1009M	1/8 BSPT	M10 x 1.0

ITEMS FOR PUMPS WITH RETURN TO TANK PORTS


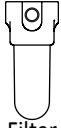

	Model No.	MM-6000
	Horsepower	1/4
	Type	Fully closed
	Output	250W
	Pole	4P
	Time Interval	Continuous
	Revolution	1400/1700 RPM
	Voltage	110V
	Frequency	50/60 Hz

Illustration	Model No.	Thread Size
 Filter	MF-6000	1/4 NPT

	Model No.	Theoretic Discharge Capacity (cc/rev)	l/min Discharge Capacity		Max. Pressure (Kgf/cm ²)	Max. RPM	Thread Size
			1500 RPM	1800 RPM			
	MP-6000	2.5	3.7 l/min.	4.5 l/min.	5	1800	1/4 NPT



TECHNICAL INFORMATION

OIL SELECTION FOR CENTRAL LUBRICATION

Many manufacturers of equipment that use central lubrication systems will recommend the specific lubricating oil to be used. If a particular oil is not recommended, then several factors must be considered. Load and friction elements of surfaces to be lubricated are a primary consideration. The ambient temperature during machine operation, and also the speed of the equipment are significant factors. The viscosity of the oil is a measure of how the oil flows at a given temperature. Both the temperature and the operating pressure will determine the resistance to flow of the oil. As the pressure or temperature increases, the oil delivery rate is increased.

Always use clean oil in central lubrication systems. Contamination in the oil will significantly shorten the life of the surfaces being lubricated. Synthetic lubricants tend to be more stable than mineral based ones. However, some synthetic lubricants can attack standard seal material, and seal compatibility must be checked before using any oil type.

To insure the correct choice of lubricating oil, consult the machinery manufacturer or OEM.

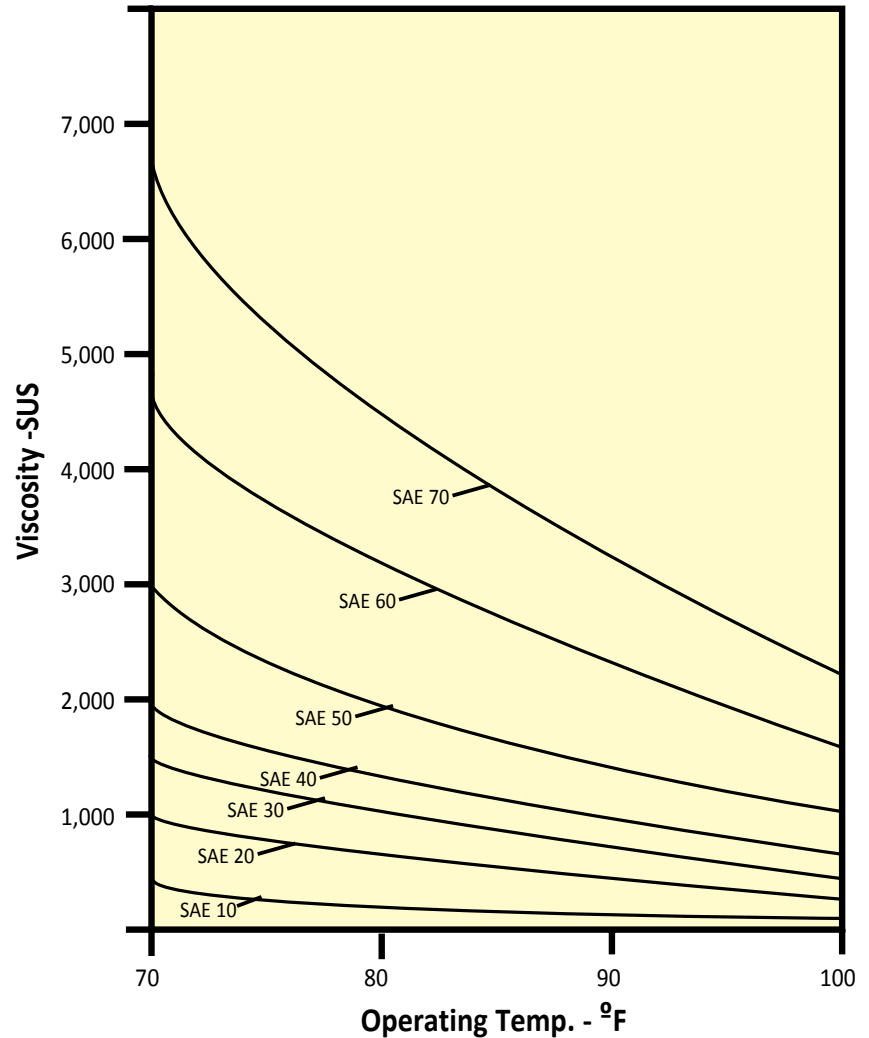
VISCOSITY OF OIL LUBRICANTS

Trico pumps are designed to dispense mineral based lubricants with a viscosity range of 30-250 centistokes or 150 - 1200 SUS. New clean oil is always recommended and users should check with machine manufacturers for the recommended lubricant for their equipment.

METRIC CONVERSION CHART

1 oz.	30 ml./30cc.
1 pt.	.473 liters
1 qt.	.946 liters
1/2 gal.	1.89 liters
1 gal.	3.785 liters

TEMPERATURE VISCOSITY RELATIONSHIP



USING THE SYSTEM DESIGN WORKSHEET

INSTRUCTIONS - Follow the instructions as listed below using the worksheet. The worksheet is designed for cyclic systems. For assistance with continuous systems, contact Trico.

STEP 1 - List the lubrication points in the system.

In column A, list each lubricant point by description.

STEP 2 - Determine the lubrication required at each point.









In column B, write the lubrication delivery required at each point in cc/hr. Enter the total delivery required in the total box. Refer to the specification from the machinery manufacturer whenever possible. The Lubricating Calculations table below can be used as a guide in determining lubrication requirements.

STEP 3 - Determine the flow ratios for each lubrication point.

Find the lubrication point requiring the least amount of oil. Divide each of the "Lube Delivery Req'd" values by that amount. Enter these values in column C. This will determine the ratio of lubrication required between all of the lubrication points.

LUBRICATING CALCULATIONS

If the amount of lubrication needed is not specified by the equipment manufacturer, this table can be used as a guide.

Illustration	Application	Oil Required in cc/hour
	Ball Bearings	.10 x bearing diameter (in.) x number of rows or bearings
		.04 x bearing diameter (cm.) x number of rows or bearings
	Plain Bearings	.15 x bearing shaft diameter (in.) x bearing length (in.)
		.023 x bearing shaft diameter (cm.) x bearing length (cm.)
	Flat Sides	.04 x [slide length (in.) + travel (in.)] x slide width (in.)
		.006 x [slide length (cm.) + travel (cm.)] x slide width (cm.)
	Cylindrical Slides	.15 x [slide length (in.) + travel (in.)] x slide diameter (in.)
		.023 x [slide length (cm.) + travel (cm.)] x slide diameter (cm.)
	Ball Bearing Slides	.03 x slide length (in.) x number of slides or rows
		.012 x slide length (cm.) x number of slides or rows
	Cams	.08 x surface area (sq. in.)
		.013 x surface area (sq. cm.)
	Gears	.30 x gear pitch diameter (in.) x face width (in.)
		.046 x gear pitch diameter (cm.) x face width (cm.)
	Chains	.05 x length of chain (in.) x width (in.)
		.008 x length of chain (cm.) x width (cm.)



USING THE SYSTEM DESIGN WORKSHEET

SIZING CHARTS

C Ratio		D Multip.	E Flow Rate	F "Q" Value
From	To			
1.00	1.50	1	0	5
1.51	3.00	2	1	10
3.01	6.00	4	2	20
6.01	12.00	8	3	40
12.01	24.00	16	4	80
24.01	48.00	32	5	160

CHART 1

C Ratio		D Multip.	E Flow Rate	F "Q" Value
From	To			
1.00	1.50	1	00	2.5
1.51	3.00	2	0	5
3.01	6.00	4	1	10
6.01	12.00	8	2	20
12.01	24.00	16	3	40
24.01	48.00	32	4	80
48.01	96.00	64	5	160

CHART 2

C Ratio		D Multip.	E Flow Rate	F "Q" Value
From	To			
1.00	1.50	1	3/0	1.25
1.51	3.00	2	00	2.50
3.01	6.00	4	0	5
6.01	12.00	8	1	10
12.01	24.00	16	2	20
24.01	48.00	32	3	40
48.01	96.00	64	4	80
96.01	192.00	128	5	160

CHART 3

STEP 4 - DETERMINE WHICH OF THE THREE SIZING CHARTS TO USE.

Find the highest ratio listed in Column C. If the highest value is 48 or less, then use sizing chart 1 in step 5. If it is between 49 and 96, then use chart 2 in step 5. If it is between 97 and 192, then use chart 3 in step 5.

STEP 5 - MULTIPLIER, FLOW RATE, AND Q VALUE AMOUNTS.

Referring to Sizing Chart 1, 2, or 3, fill in the appropriate multiplier, flow rate, and Q value for each lubrication point. Enter the totals for the multipliers and Q values in the total boxes.

STEP 6 - CALCULATE ACTUAL DELIVERY FOR EACH LUBRICATION POINT.

To confirm the actual delivery that each lubrication point will receive, the following calculation is done. For each lubrication point, divide the total oil required in the system by the total of all the multipliers. Multiply that number by the multiplier for that lubrication point. Record the amount in column G.

STEP 7 - CHECK FOR FLOWABILITY.

Divide the viscosity of the oil (SUS at operating temperature), by the total of all the Q values for the system. If the result of that calculation is 61 or less then the system has flowability. If the result is higher than 61, larger meter units are required. Increase each meter unit flow rate value by one size. Add the new Q values that correspond, and repeat the calculation. Continue to do this until the flowability calculation is 61 or less.

STEP 8 - SELECT THE APPROPRIATE PUMP.

Using the pump selection chart, select a pump best suited for the application.

STEP 9 - CHOOSE THE APPROPRIATE METER UNITS.

Column E has the designated flow rate for each of the meter units. Select the meter unit with thread configuration best suited for each application point.

SYSTEM DESIGN WORKSHEET

Please visit our website for assistance on designing a central lubrication system at www.tricocorp.com/technical/central-lub-worksheet.aspx.

Machine: _____

Lubricant: _____ Viscosity: _____ SUS at _____ °F Oper. Temp.

Prepared By: _____ Date: _____

Lube Point No.	(A) Lubricant Point Description	(B) Lube Delivery Req'd cc/hr	(C) Ratio Between Lube Points	(D) Multiplier	(E) Flow Rate	(F) Q Value	(G) Actual Delivery cc/hr
1							
2							
3							
4							
5							
6							
7							
8							
9							
10							
11							
12							
13							
14							
15							
16							
17							
18							
19							
20							
		Delivery Total		Multiplier Total		Q Value Total	

HELPFUL TIP:

The above worksheet is for designing an automatic cyclic system. When designing a continuous system, please contact Trico's customer service for assistance.



PRODUCT SELECTION CHARTS

INSTRUCTIONS

Find the Flow Rate value for each lubrication point. This corresponds to the flow rate values in the Meter Units chart. Select the mounting configuration best suited for the application. Additional information regarding the mounting configuration is found on the opposite page.

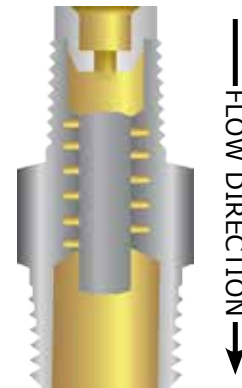


METER UNITS

Flow Rate	5/16-24 x 5/16-24	5/16-24 x 1/8 NPT	1/8 NPT x 1/8 NPT	M8 x 1.0 x M8 x 1.0	M8 x 1.0 x 1/8 BSPT	1/8 BSPT x 1/8 BSPT
3/0	DSM-3/0	DCM-3/0	DTM-3/0	—	—	—
00	DSM-00	DCM-00	DTM-00	DSM-00M	DCM-00M	DTM-00M
0	DSM-0	DCM-0	DTM-0	DSM-0M	DCM-0M	DTM-0M
1	DSM-1	DCM-1	DTM-1	DSM-1M	DCM-1M	DTM-1M
2	DSM-2	DCM-2	DTM-2	DSM-2M	DCM-2M	DTM-2M
3	DSM-3	DCM-3	DTM-3	DSM-3M	DCM-3M	DTM-3M
4	DSM-4	DCM-4	DTM-4	DSM-4M	DCM-4M	DTM-4M
5	DSM-5	DCM-5	DTM-5	DSM-5M	DCM-5M	DTM-5M

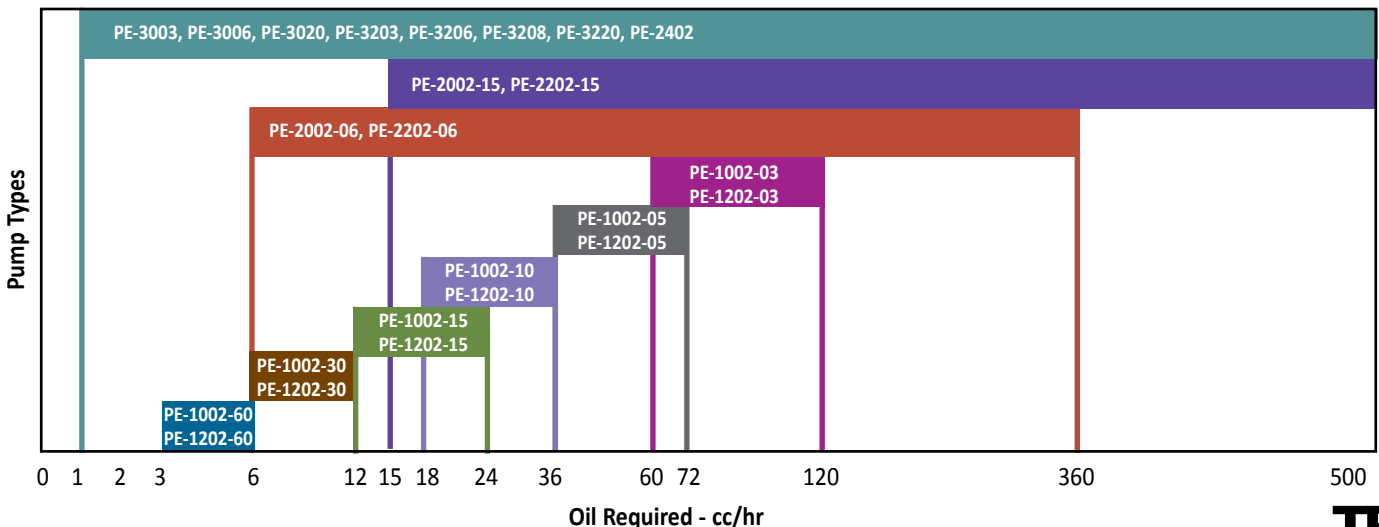
CONTROL UNITS

Flow Rate	5/16-24 x 5/16-24	5/16-24 x 1/8 NPT	1/8 NPT x 1/8 NPT	M8 x 1.0 x M8 x 1.0	M8 x 1.0 x 1/8 BSPT	1/8 BSPT x 1/8 BSPT
5/0	—	DCC-5/0	DTC-5/0	—	—	—
4/0	DSC-4/0	DCC-4/0	DTC-4/0	—	—	—
3/0	DSC-3/0	DCC-3/0	DTC-3/0	—	—	—
00	DSC-00	DCC-00	DTC-00	—	—	—
0	DSC-0	DCC-0	—	—	—	—
1	DSC-1	DCC-1	DTC-1	DSC-1M	DCC-1M	DTC-1M
2	DSC-2	DCC-2	DTC-2	DSC-2M	DCC-2M	DTC-2M
3	—	—	DTC-3	DSC-3M	DCC-3M	—
4	DSC-4	DCC-4	—	DSC-4M	DCC-4M	—
5	DSC-5	—	DTC-5	—	DCC-5M	—



INSTRUCTIONS Find the total oil required for all lubrication points. Select a pump that is in the desired flow range. Refer to the Trico catalog for information on the specific features of the different pumps.

SELECTION CHART FOR AUTOMATIC CYCLIC PUMPS



DISTRIBUTION NETWORK DESIGN

Selecting the distribution network components begins with a sketch or layout of the system. Hardware will be different when the lubrication points are some distance apart or are close together. Many systems will be combinations of distant and close lubrication points. The general sequence is A) Select the pump location B) determine how your meter units or control units will mount at each point and C) develop interconnecting plumbing.

A. Pump Location

Several key considerations are:

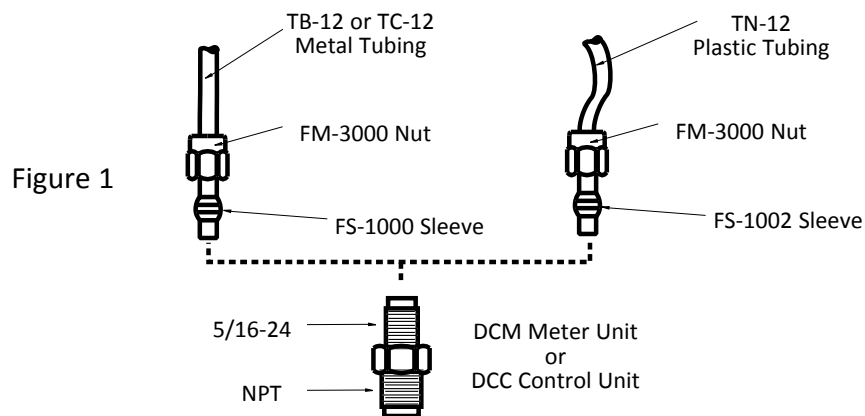
1. Install the pump to be visible to the machine operator or maintenance person. This will simplify checking lubricant levels.
2. Make sure that there is easy access for refilling the reservoir.
3. Access to electricity for automatic pumps should be convenient and safe.
4. Generally, the pump is mounted lower than the majority of the points being lubricated to avoid trapped air.

B. Meter Unit or Control Unit Installation

There are three mounting options to choose from in both meter units and control units.

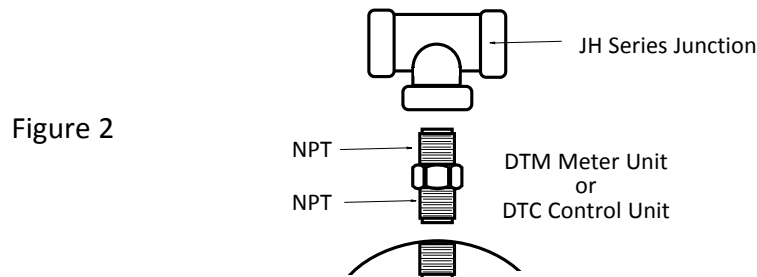
1. Direct Mounting

In these applications, the meter or control unit is connected directly to the lubrication point and a single line is connected to it (fig. 1). One end of the meter or control unit is NPT or BSPT and the other end is a 5/16-24 or metric straight thread.



2. Tee Mounting

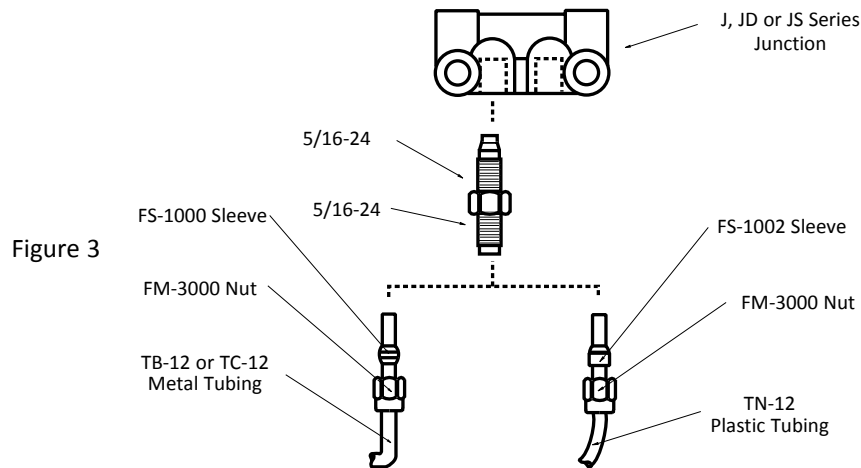
In these applications, the meter or control unit is connected directly to the lubrication point and a junction is connected on the other end (fig. 2). Both ends of the meter or control unit are NPT or BSPT.



DISTRIBUTION NETWORK DESIGN

3. Remote Mounting

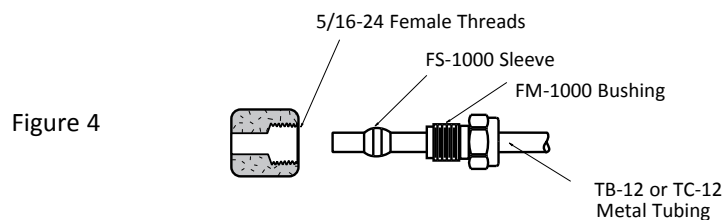
In these applications, the meter or control unit is not connected to the lubrication point. One end of the meter or control unit is connected to a junction, and the other end is connected to tubing that goes to the lubrication point (fig. 3). Both ends of the meter or control unit are 5/16-24 or metric straight threads.



C. Interconnecting Plumbing

There are several considerations to make when connecting a central lubrication system.

1. Tubing Type - Metal or plastic tubing are the 2 choices available. When using metal tubing, copper tubing is the easiest to install. Steel is stronger, but more difficult to install.
2. Hoses - When connecting lubrication points that move, the use of a hose is recommended. Allow adequate hose length to prevent kinking, stretching, or twisting.
3. Tubing Fittings - Refer to figures 1, 2, and 3 for examples of how the tubing fittings connect. When connecting tubing to a female thread, use the FM-1000 series bushings in place of the FM-3000 series nuts (fig. 4).



4. Pressure gauges - Pressure gauges should be installed in central lubrication systems to verify that adequate oil pressure is getting to each lubricant point. Depending on the size of the system, one or more gauges may be installed at different points. A gauge installed at the furthest point from the pump is useful in determining if the entire system is receiving adequate oil pressure.
5. Check valves - Check valves are used to hold pressure in a line and prevent dripping and leaking. Meter units contain internal check valves, and control units do not need check valves because of the constant flow. Separate check valves can be installed when the meter unit is not located at the point of lubrication. Installing the check valve between the meter unit and the lubricant point will maintain an oil supply in the lubrication line.

INTRODUCTION TO MINIMUM QUANTITY LUBRICATION

For over a decade, the concept of minimum quantity lubrication, sometimes referred to as “near dry machining”, has been suggested as a means of addressing environmental concerns and occupational hazards associated with airborne mist. In most instances, when cutting fluids are used, an airborne mist is released into the air that eventually falls to shop floors, causing concern for employee health and safety. By minimizing the use of cutting fluids economical benefits can be achieved; such as reduced costs of lubricant and disposal, as well as machine and workpiece cleaning time.

WHAT IS MINIMUM QUANTITY LUBRICATION?

The basic principal of minimum quantity lubrication is the utilization of precision dispensers to apply the smallest amount of lubricant (typical applications use 1 oz. of lubricant in an 8-hour shift) needed to effectively perform the metal cutting operation. These dispensers help eliminate friction at the tool chip interface by minimizing the heat that can be generated. Special lubricants, such as Tri-Cool MD-1 and MD-7, are used with these dispensers which are virtually consumed during the machining operation, resulting in residue-free machine surfaces and work pieces, and the elimination of airborne mist.

BENEFITS OF MINIMUM QUANTITY LUBRICATION

When using minimum quantity lubrication dispensers, the following benefits will be achieved:

- Increased tool life
- Increased material removal
- Improved tolerances
- Improved surface finish
- No sump maintenance
- Less machine downtime
- No coolant disposal costs
- Higher resale value of chips
- Elimination of airborne mist



Minimum quantity lubrication used on a horizontal saw



Minimum quantity lubrication used during a milling operation



Minimum quantity lubrication used on a tapping workcenter

MD-1200 MICRO-DROP®

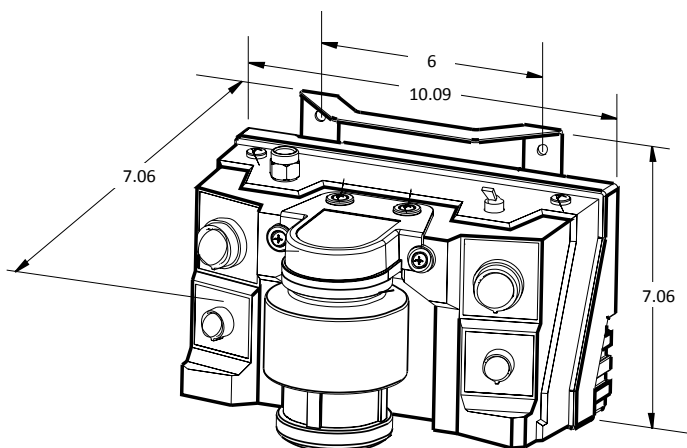


The MD-1200 Micro-Drop® dispenser provides a cost effective solution when flood cooling is impractical or unavailable. When used in milling, tapping, and sawing applications, the MD-1200 dispenses small amounts of Tri-Cool Micro-Drop synthetic or vegetable based lubricant. Compared to flood cooling, there is no coolant sump to maintain or used coolant to dispose of. The MD-1200 offers higher material removal rates, improved part finish, longer tool life, and tighter dimensional tolerances.

Solenoid versions allow these units to be interfaced with CNC controls or other signaling devices. The pressurized delivery system of the MD-1200, provides instant on/off performance when used with the solenoid control.

SPECIFICATIONS

System Type	Pressure Delivery, Non-Cyclic
Delivery Lines	6 ft. Polyurethane
Nozzles	18" Loc-Line or 13" Copper
Liquid Flow Range	2-16 Drops/Minute
Liquid Viscosity	50-200 SUS
Inlet Air Pressure	60-125 PSI
Recommended Air Filter	40 Micron
Air Consumption	1.7 CFM/Line
Air Inlet Fitting	1/4 NPT
Solenoid Voltages	120V 60Hz
Dimensions	7.06" H x 10.09" W x 7.06" D
Reservoir Capacity	16 oz.



SELECTION CHART

Model No. with Lock-Line Nozzles	Model No. with Copoper Nozzles	Description
30801	30813	1 Line, Manual On/Off
30802	30814	2 Line, Manual On/Off
30805	30817	1 Line, Solenoid On/Off
30806	30818	2 Line, Solenoid On/Off

HELPFUL TIP:

The MD-1200 Micro-Drop should not be used with a water-soluble coolant. These types of fluids will damage and clog system components. Trico offers a line of lubricants that is ideal for use with the MD-1200. Please see Tri-Cool Fluids document for Tri-Cool MD-1 and MD-7.



OPTIONS

Copper Nozzles replace the flexible plastic lines in applications where the nozzle position is fixed. Copper nozzles are supplied straight, and are easily bent to the desired nozzle position.



Magnetic Mounting Kit - Model No. 30687

Simplifies mounting when used in portable applications.

Typical applications use 1 oz. of lubricant in an 8-hour shift.

Positive pressure design gives instant fluid delivery for faster cycle times.

The MD-1200's anti-siphon valves permit the nozzles to be mounted in any position.

Relative liquid scale allows repeatable set-ups and saves time in adjusting flow rates for different applications.

Independent controls allow for maximum flexibility in adjusting liquid and air flow for each nozzle.

Simple easy-to-use controls. No confusing timer to set.

High energy nozzle design eliminates fogging for cleaner environment and greater chip clearing power, allowing faster speed and feeds.

REPLACEMENT NOZZLE TIP

Model No.	Description
20024R	Nozzle Tip for Plastic or Copper Nozzle



INTRODUCTION TO SPRAY COOLING

The need for providing coolant to metal removal operations is readily accepted in machining industries. Spray cooling provides the benefits of coolants used in flood applications with the added performance of a high velocity air/coolant mixture. It is used where high speed tools and saw blades require powerful chip clearing, and offers coolant application where flood cooling is inadequate. In addition, spray cooling is also used in processes that generate high amounts of heat at the tool chip interface. Delivering a low volume of coolant at a high velocity, spray cooling is able to remove heat as fast as possible, which is critical in maximizing productivity and quality. Also, it helps keep expendable tooling costs in line. Trico offers three separate types of delivery systems for dispensing a wide range of coolants in many metal removal processes: siphon, pump, and pressure delivery.

SIPHON DELIVERY SYSTEMS

Siphon type units use the flow of air across an orifice to draw or pull fluid from the reservoir to the nozzle tip. There are no moving parts. These siphon type units cover a range of applications from light to moderate with up to six nozzle capability. The use of multiple nozzles allows adequate coverage when tool sizes are large or heat generation is great. Typical locations for use would be machine shops, tool rooms, prototype areas, or small machining work cells. These units are economically priced and can cover secondary machining applications not equipped with coolant capabilities. Drilling, tapping, milling, turning, sawing, etc. are examples of applications that can be improved with the various siphon units that are offered.

PUMP AND PRESSURE DELIVERY SYSTEMS

For more sophisticated and demanding metal removal processes, or where more than six nozzles are necessary, the pump or pressure type delivery systems are recommended. These are also recommended for higher viscosity fluids, up to 1000 SUS. The



Spray cooling during milling operation

pump type uses a mechanical pump to force fluid from the reservoir and the pressure type uses an air pressurized reservoir to force fluid to the nozzles. With the coolant being delivered with positive pressure in either case, a wide range of coolant stream definition can be attained. From air only to mini-flood streams, the wide range available for adjustment, allows the user to set delivery to the specific

application requirements. Applications covered by these systems include dedicated secondary machines, transfer lines, conveyors, large capacity tooling, through the tool and machining cells. The multiple nozzle/valve combinations also allow for customizing systems specific to end user applications.

METAL REMOVAL FACTS

1. **Metal removal methods generate friction. Two types of friction generate heat:**
 - a. External friction, where approximately a third of the heat is generated, metal to metal contact of the work tool to the work piece
 - b. Internal friction, where approximately two-thirds of the heat is generated, resistance of metal atoms to movement when the metal is deformed in the shear zone
2. **There are many variables at the interface of the tool and the work piece that influence the effectiveness of your cut.**
 - a. Tool material, tool design, tool size, speed of tool, depth of cut, feed rate, work piece material, type of operation, type of equipment, and coolant/lubricant method are just some of these variables.
3. **Equipment, operation, tooling, material, part quantity, secondary operations, and safety could dictate the method of cooling/lubricating to use.**
 - a. Equipment: flood system ready, compressed air
 - b. Operation: milling, drilling, tapping, sawing, etc
 - c. Tooling: carbide, diamond, ceramics, special coatings
 - d. Material: brass, aluminum, steel, stainless, plastics
 - e. Part quantity: one to ten, short runs, long runs (cycle time)
 - f. Secondary operations: plating, anodizing, painting, machining
 - g. Safety: work piece handling in fixtures or chucking, work area
4. **There is no single method that works best in all metalworking applications**
 - a. Cutting fluids do one or more of the following functions:
 - i. Cool the tool, work piece and chip
 - ii. Reducing friction by minimizing erosion of the tool by lubricating
 - iii. Remove chips from the work area
 - iv. Protect the work piece, tooling and machine from corrosion
5. **The application method needs to apply the fluid properly to achieve any or all of the above functions economically**
6. **Spindle speed, feed rate and depth of cut can also determine your method**
 - a. Spindle speed, high, intermediate, low - cool or lubricate
 - i. High speed requires more cooling
 - ii. Intermediate speeds require both cooling and lubricating
 - iii. Low speeds require more lubricating
 - b. Feed rate
 - i. Quicker feed rates generate more heat and requires more cooling
 - ii. Slow feed rates require more lubricating
 - c. Depth of cut
 - i. Chip evacuation, cooling and lubricating required



DL & DL MAGNUM

The DL and DL Magnum spray cooling systems provide cooling solutions for light duty machining and tool room applications. These dispensers are easy to install requiring only shop air and dropping the siphon line into a coolant tank.



FEATURES

DL

- Siphon delivery system
- 7 in. flexible segmented nozzle
- Solid brass precision needle valve and body
- 7 ft. coolant pickup line with stainless steel filter
- Sturdy 60 lb. magnetic base with mounting arm
- Assembles in less than five minutes

DL Magnum

- Siphon delivery system
- 15 in. heavy duty metal nozzle conduit
- Advanced nozzle design for increased chip clearing power and reduced overspray
- Independent air and liquid controls
- 6 ft. coolant pickup line with stainless steel filter
- Sturdy 60 lb. mounting magnet
- Check valve minimizes delay of fluid upon start-up
- BSPT threads (green model numbers) are available

SPECIFICATIONS

	DL	DL Magnum
Valve Body	Brass	Plated Brass
Seals	Buna-N	Buna-N
Siphon Line	Polyurethane	Polyurethane
Filter Element	40 x 40 Mesh Stainless Steel	40 x 40 Mesh Stainless Steel
Pressure	50-100 PSI	60-120 PSI
Air Inlet	1/8 NPT	1/4 NPT or 1/4 BSPT
Fluid Type	Water based coolants suitable for spray cooling	Water based coolants suitable for spray cooling

SELECTION CHART

Model No.	Description
30660	DL Dispenser
30655	DL Dispenser w/ 1 qt. Tri-Cool Coolant
30632	DL Magnum Dispenser, 1/4 NPT
30633	DL Magnum Dispenser w/ 1 qt. Tri-Cool Coolant, 1/4 NPT
30634	DL Magnum Dispenser, 1/4 BSPT
30635	DL Magnum Dispenser w/ 1 qt. Tri-Cool Coolant, 1/4 BSPT



LI'L MISTER® SYSTEMS



30541

Li'l Mister® Systems offer spray cooling with features normally available with higher cost units. The compact size with a 1 quart reservoir makes the Li'l Mister ideal for tool room and other light duty machining applications. Typical applications include drilling, milling, turning, grinding, and tapping.

FEATURES

- Siphon delivery system
- Easy reading sight gauge
- 5 ft. plastic or brass armored line
- Easy mounting bracket
- Independent air/coolant adjustability
- One quart reservoir capacity
- 6 in. straight brass nozzle standard
- Size - 8 1/2" H x 5 1/4" W x 4" D

HELPFUL TIP:

The Li'l Mister is designed to be used with a water-soluble coolant. See Tri-Cool Fluids on page O2.

SPECIFICATIONS

Reservoir	High Density Polyethylene
Sight	Acrylic Plastic
Valves	Brass
Seals	Buna-N
Delivery Line	5 ft. Brass or Plastic
Coolant Tube	Polyurethane
Filter Element	40 x 40 Mesh Stainless Steel
Air Inlet	1/4 NPT
Air Inlet Pressure	50-100 PSI

SELECTION CHART

Model No.	Capacity (qts.)	No of Lines	Line Length (ft.)	Line Material
30540	1	1	5	Plastic
30541	1	1	5	Brass

ACCESSORIES

MAGNETIC NOZZLE HOLDERS

Magnetic nozzle holders facilitate the placement and directing of the nozzle.

Model No.	Description
30460	30 lb. Holder
30630	60 lb. Holder
30142	165 lb. Holder

NOZZLES

Model No.	Capacity (qts.)	No of Lines
30490	6"	Straight
30491		45° Angled
30492		90° Angled
30493		Flexible Loc-Line



Spraymaster® systems provide convenient spray cooling in metal cutting. Requiring only compressed air as a power source, these units are easily installed in many machining applications.

The Spraymaster is designed for use with Tri-Cool synthetic coolant. Various mixtures of coolant to water may be used depending upon individual requirements.

Stainless steel reservoir versions are available with the same performance features as the standard Spraymaster.

FEATURES

- Siphon delivery system
- Air and coolant are independently controlled by solid brass precision needle valves
- Brass armored lines are a standard 5 foot length
- 6 in. straight brass nozzle is designed so atomization takes place at nozzle tip for enhanced pattern control
- Mounting brackets included for easy installation
- 1 or 2 outlet line models provide maximum flexibility
- Liquid level gauge easily indicates coolant level at a glance
- Polyethylene dimensions: 12-1/4" H x 10" W x 5-1/4" D
- Stainless steel dimensions: 9-3/8" H x 8-3/8" W x 5-1/4" D



SPECIFICATIONS

Cover	High Density Polyethylene
Reservoir	High Density Polyethylene or 20 Gauge 304 Stainless Steel
Valves	Brass
O-Rings	Buna-N
Delivery Line	Brass Armored
Coolant Tube	Polyurethane
Fittings	Brass
Filter Element	40X40 Mesh Stainless Steel
Air Inlet	1/4 NPT

SELECTION CHART

Model No.	Reservoir Type	Capacity (gal.)	No. of Lines	Line Length (ft.)
30542	High Density Polyethylene	1	1	5
30543			2	
30548	Stainless Steel		1	
30549			2	

HELPFUL TIP:

SprayMaster units are designed to be used with a water-soluble coolant. See Tri-Cool Fluids on page O2.

ACCESSORIES

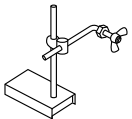
NOZZLES

Spraymasters are supplied with straight nozzles. Other nozzle types are available for customer installation.

Model No.	Length	Type
30490	6"	Straight
30491		45° Angled
30492		90° Angled
30493		Flexible Loc-Line

MAGNETIC NOZZLE HOLDERS

Magnetic nozzle holders facilitate the placement and directing of the nozzle.

	Model No.	Description
	30460	30 lb. Holder
	30630	60 lb. Holder
	30142	165 lb. Holder



SPRAYMASTER® II



FEATURES

- Siphon delivery system
- High performance 7 in. flexible segmented plastic nozzle
- Solenoid control for instantaneous response
- 1 or 2 outlet, 5 ft. brass armored lines
- Easy to read coolant sight gauge
- Easy to mount reservoir bracket for permanent mounting to application
- Independent air and coolant controls for lean to rich spray delivery
- Size: 12-1/4" H x 10" W x 5-1/4" D

HELPFUL TIP:

SprayMaster II units are designed to be used with a water-soluble coolant. See Tri-Cool Fluids on page N2.

The SprayMaster II is designed for applications where the ability to cycle the delivery is required. Solenoid control of spray coolant allows instant on-off operation for use in fixtured secondary machining. Solenoid control also conserves on coolant use during load and unload portion of cycle.

This model is available with two lines for maximum coolant delivery or pattern control. The Spraymaster II can be interfaced with a wide range of signaling devices for automatic delivery applications.

SELECTION CHART

Comes complete with UL and CSA approved 110 volt, 60 Hz power cord. Fused and fully grounded.

Model No.	Capacity (qts.)	No of Lines	Line Length (ft.)
30458	1	1	5
30459	1	2	5

ACCESSORIES

NOZZLES

Model No.	Length	Type
30260	6"	Straight
30622	7"	Flexible Plastic
30623	12"	

SPECIFICATIONS

Reservoir	High Density Polyethylene
Sight	Acrylic Plastic
Valves	Brass
Seals	Buna-N
Delivery Line	5 ft. Brass Armored
Coolant Tube	Polyurethane
Filter Element	40 x 40 Mesh Stainless Steel
Solenoid	Brass Body & S/S Plunger
Air Inlet	1/4 NPT
Air Inlet Pressure	50-100 PSI

MAGNETIC NOZZLE HOLDERS

Magnetic nozzle holders facilitate the placement and directing of the nozzle.

	Model No.	Description
	30460	30 lb. Holder
	30630	60 lb. Holder
	30142	165 lb. Holder



MISTMATIC® COOLANT DELIVERY SYSTEMS

The Mistmatic® allows the user a wide range of coolant delivery. Variable adjustability allows deliveries such as lean, rich, high velocity, or low velocity. Unit can fill “mini-flood” applications with the dual control valving. This unit can cover most machining requirements. Multiple metal removal processes ranging from broaching to grinding can be covered with the Mistmatic. The pressure pumping design of the Mistmatic allows use with a wide range of coolants compatible with Buna-N seals and lower than 1000 SUS viscosity. Auto electric models can be interfaced with machine controls for cyclic capabilities.



FEATURES

- Pump operated system
- HV-3100 control valve with 7 in. segmented plastic nozzle
- One or two outlet, 5 ft. brass armored lines
- Independently adjusted air and coolant allows for balancing coolant delivery
- Platform design capabilities allow for flexible line/nozzle combinations (consult factory)
- Easy reading sight gauge
- 1 gallon reservoir capacity
- Reservoir bracket for easy mounting directly to machining application
- 1 gallon dimension = 10 1/2" H x 8 1/2" W x 6" D

SPECIFICATIONS

Reservoir	High Density Polyethylene
Sight	Acrylic Plastic
Check Valve	Brass w/Buna-N Seals
Seals	Buna-N
Delivery Lines	5 ft. Armored Brass
Coolant Tube	Polyurethane
Valves	Brass
Solenoid	Brass Body & S/S Plunger
Nozzle	Flexible Segmented Plastic Standard
Pump	Acetal Copolymer w/Buna-N
Tubing	Polyurethane
Air Inlet	1/4 NPT
Air Inlet Pressure	50 -100 PSI

NOZZLES

Model No.	Length	Type
30620	7"	Flexible Plastic
30267		Flexible Metal
30621	12"	Flexible Plastic
30268		Flexible Metal

SELECTION CHART

Model No.	No. of Lines	Control Mode	Voltage (VAC)
30600	1	Manual	—
30601	2	Manual	—
30604	1	Auto	120*
30605	2	Auto	120*

*Other voltages on request



COOLANT DELIVERY SYSTEMS

Both the 30034 and 30095 systems cover coolant delivery applications ranging from single point applications to multiple point (up to 100) applications. With the use of a variety of signaling devices, custom machining application cooling and lubricating can be accomplished. With the nozzle/valve designs available, individual machine and tool requirements can be serviced from one platform design tank or pump. The dual control valves allow a delivery range from air only, to mini-flood, and a variety of spray streams. Applications ranging from broaching to grinding are covered using these combinations.

FEATURES

30034 Dispenser

- Pressure delivery system
- 5 gallon stainless steel ASME certified tank
- Cam action fill cover cannot be opened when unit is pressurized
- Large opening for filling
- Air regulator, gauge, coolant filter, pressure relief valve and two way shut off valve included

30095 Pump

- Pump operated system
- Large capacity delivery capability - up to 100 individual nozzles
- Pump works on stall pressure as coolant is delivered saving compressed air
- Pump installs into 2 in. bung in drums or tank allowing quick changeover of coolant supply
- Air only needed for operation
- Air regulator, gauge, coolant filter, quick-disconnects and fittings included

Control Valves

- Solid brass valve construction
- Precision needle valves allow for infinite pattern delivery
- Valve and nozzle design allows for multiple delivery potential
- P-12A has built-through feature for simplified installation with other valves
- HV-2100 has valve controls close to nozzle delivery point



30034

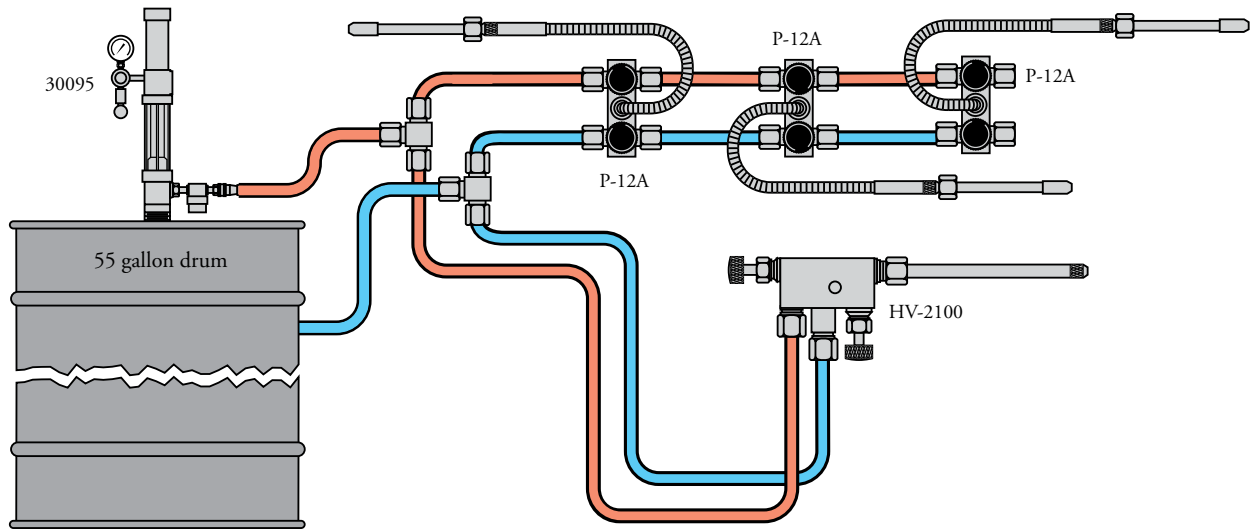
30095

SELECTION CHART

Model No.	Description
30034	5 Gallon Dispenser
30095	1:1 Ratio Pump - 2" Bung Fitting



COOLANT DELIVERY SYSTEMS



SPECIFICATIONS - PUMPS/DISPENSERS

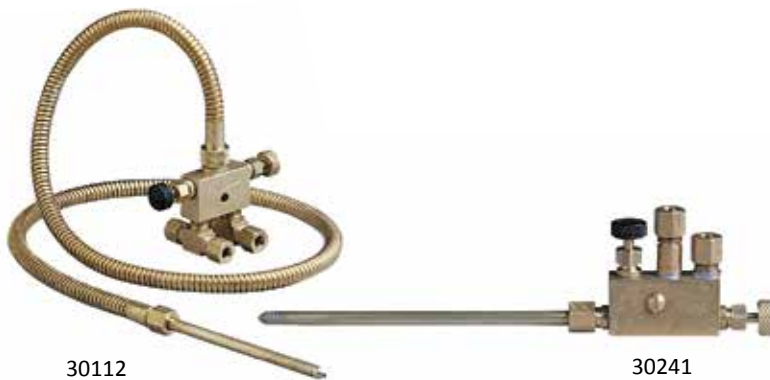
	30034	30095
Material	Type 304 Stainless Steel	Carbon Steel
Capacity	5 gal.	Reservoir Size
Seals	Buna-N	Viton® and Teflon
Packing	—	Polyethylene
Fitting	Brass	
Filter	40 x 40 Mesh Stainless Steel	
Controls	0–100 PSI Regulator and Gauge	
Size	24 1/2" x 9"	51" x 10"
Connections	1/4 NPT Quick Coupling Inlet 1/4" O.D. Tube Outlet	1/4 NPT Quick Coupling Inlet 3/8" Quick Coupling Outlet
Air Pressure	50–100 PSI	

SELECTION CHART—CONTROL VALVES

Model No.	For Use With	Nozzle
30240	HV-2100	3" Straight
30241		6" Straight
30256		7" Flexible Plastic
30112	P-12A	4" Straight

NOZZLES

Model No.	For Use With	Length (in.)	Type
30267	HV-2100	7"	Flexible
30268		12"	Metal



30112

30241

HOW TO ORDER

Most systems require the following minimum components: dispenser, control valve, fittings, and tubing.



INTRODUCTION TO LUBRICANTS & COOLANTS

Cutting fluids play a significant role in machining operations and impact shop productivity, tool life and quality of work. The primary function of a cutting fluid is temperature control through cooling and lubrication. A fluid's cooling and lubrication properties are critical in maximizing productivity and quality, in addition to keeping expendable tooling costs in line. Cooling and lubrication are also important in achieving the desired size, finish and shape of the workpiece. A secondary function of a cutting fluid is to flush away chips and metal fines from the tool/workpiece interface. Ultimately, this prevents a finished surface from becoming marred and reduces the occurrence of a built-up edge.

Typically, cutting fluids are manufactured with the following bases: mineral, vegetable or synthetic. Additives are added to the base oil to achieve specific performance parameters such as corrosion inhibitors, wetting agents, biocides, extreme pressure additives, and emulsifiers. Cutting fluids fall into two categories: water-soluble coolant or lubricant, each containing its own unique properties.

Water-soluble coolants are cutting fluids engineered to carry heat away from the tool chip interface. Water is the best coolant agent, but has no lubricating ability and is susceptible to contamination. Water-soluble coolants include base oil along with additives to enhance waters' ability to disperse heat. They are generally used in high-speed cutting operations such as turning and milling. Lubricants, non-soluble, are used in metal cutting operations to reduce friction. They are used in low-speed cutting operations such as broaching and tapping.

Cutting fluids are widely utilized to optimize the process of machining operations such as turning, drilling, boring, grinding, milling, drawing, stamping, and sawing. The proper selection of a cutting fluid will provide benefits such as extended tool life, increased speeds and feeds, tighter tolerance capability, and improved finish.



Micro-dispenser being filled with Tri-Cool MD-1 lubricant



Tri-Cool fluids are specially formulated to provide superior performance and long service life in various metal cutting operations on ferrous and non-ferrous metals. They have been designed to meet operator safety concerns. Tri-Cool fluids are safe to use, non-toxic, non-allergenic, and contain no harmful chemicals or additives.

- Maximize production rates
- Maximize operating costs
- Extend machine and tool life
- Increase speeds and feeds
- Increase productivity

TC-1 WATER-SOLUBLE COOLANT



TC-1 is a highly concentrated premium synthetic water-soluble coolant formulated to exceed the demands of spray and flood cooling. It contains a non-chlorine extreme pressure additive for improved tool and surface finish. TC-1 prevents rusting on tool and machine surfaces, even at lower concentrations. It contains a broad spectrum biocide/fungicide for protection against biological growth. TC-1 is non-toxic, non-flammable, non-corrosive, and biodegradable.

Model No.	Size
30656	4 gallon / case
30657	5 gallon pail
30658	55 gallon drum

SUGGESTIVE DILUTION RATIOS

Spray Cooling		Flood Application	
Operation	Dilution Ratio	Operation	Dilution Ratio
Grinding	40:1	Light Machining	32:1
General Machining	32:1	General Machining	20:1
Broach, Tap, Heavy Mach.	20:1	Heavy Machining	10:1

MD-1 MICRO-DROP® VEGETABLE LUBRICANT



MD-1 is a pure vegetable based lubricant that can be used in various metal cutting operations to achieve effective machining productivity on ferrous and non-ferrous metals. MD-1 has a heat stable, non-chlorine extreme pressure additive for improved tool life and surface finish. MD-1 is low misting, to prevent fogging in the shop. It will not stain aluminum requiring post-heat treating. MD-1 is environmentally safe and biodegradable.

Model No.	Size
30648	4 gallon / case
30647	5 gallon pail
30646	55 gallon drum

MD-7 MICRO-DROP® SYNTHETIC LUBRICANT



MD-7 is a pure synthetic based lubricant designed for use in various metal cutting operations. With the use of a Micro-Dispensing system, more effective machining productivity and savings in fluid costs can be achieved, while waste and disposal problems are reduced. MD-7 is non-toxic, non-flammable, non-corrosive, and will not become rancid.

Model No.	Size
30659	4 gallon / case
30662	5 gallon pail
30663	55 gallon drum

TRI-COOL® FLUIDS

APPLICATION GUIDE (Micro-Dispensing Lubricants)

All material used for data is 1018 \emptyset = diameter DOC = depth of cut

Process	Parameters	MD-1	MD-7
Milling (using a 1/2" \emptyset 2 flute HSS EM)	Up to 1/16 DOC	•	•
	From 1/16 to 1/4 DOC	•	•
	From 1/4 to 7/16 DOC	•	
Tapping	Up to 1/4 \emptyset	•	•
	From 1/4 \emptyset to 9/16 \emptyset	•	•
	From 9/16 \emptyset to 1 \emptyset	•	
Band Sawing	Up to 1 stock \emptyset	•	•
	From 1 to 3 stock \emptyset	•	•
	From 3 to 4 stock \emptyset	•	

APPLICATION CHART

Process		TC-1	MD-1	MD-7
Machining	Light-Duty	•	•	•
	General	•	•	•
	Heavy-Duty	•	•	
Material	Ferrous	•	•	
	Non-Ferrous	•	•	•
	Plastics		•	•
Application	Spray Cooling	•		
	Flooding	•		
	Micro-Dispensing		•	•
	Manual Application			
Fluid Type	Water Soluble	•		
	Synthetic Based	•		•
	Vegetable Based		•	





DIRECT READING FERROGRAPH

Trico's redesigned DR-7 Ferrograph is even more compact, portable and easy-to-operate. It quantitatively measures the concentration of wear particles in oil, while also providing basic wear trend data to help determine equipment condition within minutes.

The DR-7 Ferrograph utilizes a better, more efficient magnetic gradient to trap and optically measure the amount of ferrous wear particles on a scheduled basis. The instrument also establishes the baseline wear level for any piece of equipment. Any sudden increase in the wear trend level alerts the user to potential problems prompting preventive actions.

The newly redesigned DR-7 features an interactive 7" LCD touch screen, USB and Ethernet ports so you can easily plug in a keyboard, mouse, access useful reports on the web and connect it to other Ferrography instruments like the new FM-6 Ferrogram maker and the FS-6 Ferroscope.

FEATURES

- PC controlled hardware
- 4 USB port interface for external devices
- No limitations in lubricant type being monitored
- Data can be obtained quickly, generally under a few minutes
- Microprocessor incorporates internal diagnostics for reliable functioning
- 7" LCD display with a more modern look and feel
- Internal optics calibration
- New design includes a smaller footprint
- USB and Ethernet connections

SPECIFICATIONS

Length	12 in.
Width	10.75 in.
Height	21.5 in.
Weight	13 lbs.
Power	100–240 V. 50/60 Hz.
Comm-Port	RS 4222 or RS 232C selectable

SELECTION CHART

Model No.	Description
43000	Direct Reading Ferrograph (DR-7)



FERROGRAM MAKER



The newly redesigned Ferrogram Maker FM-6 dual slide maker is used in the first step in Analytical Ferrography. For greater productivity, the Ferrogram Maker FM-6 is designed with two independent stations permitting two samples to be prepared concurrently.

Each station includes a holder which accurately positions a substrate at a slight incline over a newly designed magnet, allowing particles to deposit from largest to smallest on a Ferrogram. This deposition pattern provides good resolution of large and small particles which facilitates a diagnosis of potential wear problems.

Ferrogram preparation can be done automatically, semi-automatically, or manually at the operator's option. In the automatic mode, the sample is deposited on the Ferrogram at a carefully controlled rate. At the end of the sample deposition cycle, the wash cycle is automatically initiated, and an audio and visual signal indicates completion of the Ferrogram. The semi-automatic and manual modes provide flexibility and further operator control to perform unusual samples such as greases and aqueous solutions.

The newly redesigned FM-C features an interactive 7" LCD touch screen, USB and Ethernet ports so you can easily plug in a keyboard, mouse, access useful reports on the web and connect it to our other Ferrography instruments like the new DR-G Direct Reading Ferrograph and the FS-6 Ferroscope.

SPECIFICATIONS

Depth	16 in.
Width	14 in.
Height	15 in.
Weight	27 lbs.
Power	100–240 V. 50/60 Hz.

SELECTION CHART

Model No.	Description
43010	Ferrogram Maker (FM-6)

FEATURES

- Automatic operation releases labor for other tasks
- Simultaneously produces two Ferrograms in less than 20 minutes
- Ferrograms are transparent, allowing differentiation of metallic, organic, and non-metallic particles, for easy diagnosis
- Particles are sorted by magnetic susceptibility and size enabling quick interpretation
- Very little particle stacking occurs ensuring observation of important particles, critical to machine condition
- 7" LCD display with a more modern look and feel
- New design includes a smaller footprint
- USB and Ethernet connections



FERROSCOPE FS-6

The Ferroscope FS-6 analytical ferrography optical microscope is specially assembled by Trico with attachments and options that enhance particle identification and interpretation. The Ferroscope FS-6 comes with three magnification powers -100x, 500x, 1,000x. A technician can scan a Ferrogram quickly at low power looking for obvious abnormal particles, interpret particle origin and wear mechanism at 500x, and gain more insight into stress directions at 1,000x.

The Ferroscope FS-6 is equipped with reflective and transmitted light sources so that a Ferrogram can be illuminated from above and below. A red light source illuminated above the Ferrogram causes the light to be reflected off particles and a green light source below the Ferrogram causes light to be transmitted. Any metallic particles will reflect light and non-metallic particles will transmit light.

FEATURES

- Field of view is 50% greater than previous ferrosopes, optics are infinity corrected eliminating focus problems
- Light source powers are increased in intensity over past models allowing better definition and much better photography (photomicroscopy)
- Tri-nocular system allows the addition of cameras, including video, and digital photography (microscopy)
- Bi-chromatic light (two light sources, reflected and transmitted) for identifying metallic versus non-metallic debris
- Three magnification powers; 100x, 500x, and 1000x enable rapid scanning to minute detailing
- Red and green light filters aid in identification of particle
- Polarizer and analyzers help identify particulate and fibrous contamination
- Ergonomic design enables analyst to rest arms on table while adjusting focus



SPECIFICATIONS

Depth	23.5 in.
Width	12 in.
Height	32 in.
Weight	40 lbs.
Power	100V or 220V AC

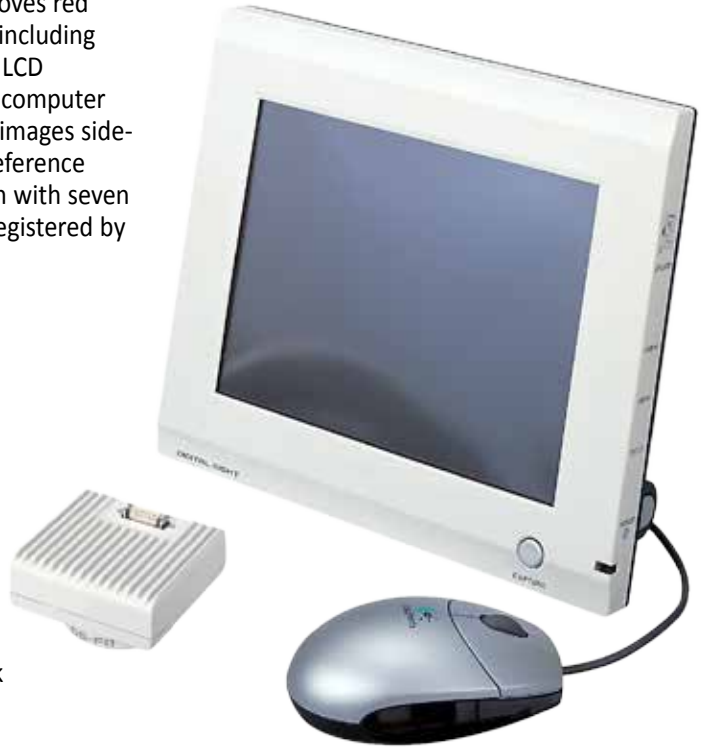


DIGITAL CAMERA

The high-definition digital camera for the Ferroscope FS-6 features a 5-megapixel CCD that can capture wear particles. The camera improves red sensitivity by using a new IR cut filter and enhances image quality, including increased brightness through 4x binning. It features a large built-in LCD monitor which can observe samples and capture images without a computer connection. The monitor can be split in half to display still and live images side-by-side to compare and contrast a sample image that serves as a reference with a live image. The monitor has exceptional color representation with seven default gamma correction presets and another seven that can be registered by the user. It allows the user to create an original reference table.

FEATURES

- Data can be saved to: USB memory stick, Compact Flash card, Mass storage class, Network
- All operations can be performed by clicking on-screen menus
- A wide variety of tools unique to this camera: Crosshairs, Measurement, Scale display
- Built-in LCD monitor—no computer required
- Contains two USB ports
- Scene mode enabling optimal image capture with a single click
- Supports direct printing; just connect the unit's USB port to a printer which supports the PictBridge standard



CAMERA SPECIFICATIONS

CCD	2/3 in high density CCD (total number of pixels 5.24 mil)
Recordable Pixels	2560 x 1920 pixels, 1280 x 960 pixels, 640 x 480 pixels
Dimensions	3" W x 3" D x 1.75" H
Weight	.5 lbs.

CONTROL UNIT SPECIFICATIONS

Digital Zoom	Up to 16x
Storage Format	BMP, JPEG (4 step compression), TIFF
Interface	USB device port x 1 (mass storage class support) USB host port x 2 (USB mouse, USB memory stick, USB keyboard, microscope connection)
Power Supply	AC100-240V 50/60 Hz
Dimensions	70VA
Weight	9" W x 2.5" D x 7.875" H
LCD Monitor	8.4" TFT color LCD XGA (1024 x 768) SXGA/XGA
Storage Media	Compact flash card (type 1, type II), USB memory stick, microdrive
Direct Printing	PictBridge printer (sold separately)

Lubrication related problems are one of the more common issues associated with asset management. Whether it is misapplied lubricants or a lubricant losing its effectiveness, lubrication problems are a source of machinery downtime and lost production. Trico can provide strategies on effective lubrication management through our training seminars, assessments, audits, consulting, and oil analysis programs. We have evolved into a global organization that provides innovative lubrication management services and programs designed to optimize equipment reliability, reduce unscheduled downtime, minimize overall maintenance expenditures, and create process and asset improvements. We provide:



TRAINING

Trico's internationally-recognized courses on Lean Lubrication Management and Effective Oil Analysis can bring your equipment maintenance best practices up to speed. Your personnel will gain valuable insight that will make your day-to-day facility operations more efficient.

ASSESSMENTS

The Lubrication Program Assessment is a critical step in improving the overall lubrication program within the plant. Trico assesses and rates your current program compared to industry best practices. We then provide a detailed report summarizing opportunities for improvement in key areas versus current efforts and conditions. This provides plant personnel with a roadmap to address plant status, and provide direction on where to focus resources to ensure improvements in equipment reliability and reductions in overall maintenance costs.

AUDITS

An Equipment Lubrication Audit is performed to obtain information about the specified equipment including its internal design, the system design, the present operation and environmental conditions. Trico will gather the necessary information and outline recommended equipment lubrication requirements.

CONSULTING

Trico's specialists in lubrication and PdM program implementation, documentation integration, and root cause analysis provide practical solutions in the interest of extending asset reliability and helping your people operate more proactively.



OIL ANALYSIS

We provide predictive condition monitoring technologies, including ferrography, used oil analysis, vibration analysis, and thermography testing. Oil samples are taken and analyzed by our laboratory as a preventative maintenance tool and/or diagnostic means to determine cause of lubricant and/or equipment failure. Oil is tested for a variety of critical factors including water, particulate, and wear material. Oil analysis can help achieve peak performance by providing advance warning of abnormal conditions that could contribute to equipment and oil degradation.

To find out how Trico can improve your lubrication management program. Contact us at 800.558.7008 or 800.543.8786. You can also visit our website: www.tricocorp.com.





TOTAL LUBRICATION MANAGEMENT SOLUTIONS.

Trico is your complete resource for the lubrication management products and services you need. Our vast array of top-grade products apply, condition and monitor the quality of your lubricants—keeping your equipment—and your people—running productively.

