

Шлицевые полумуфты

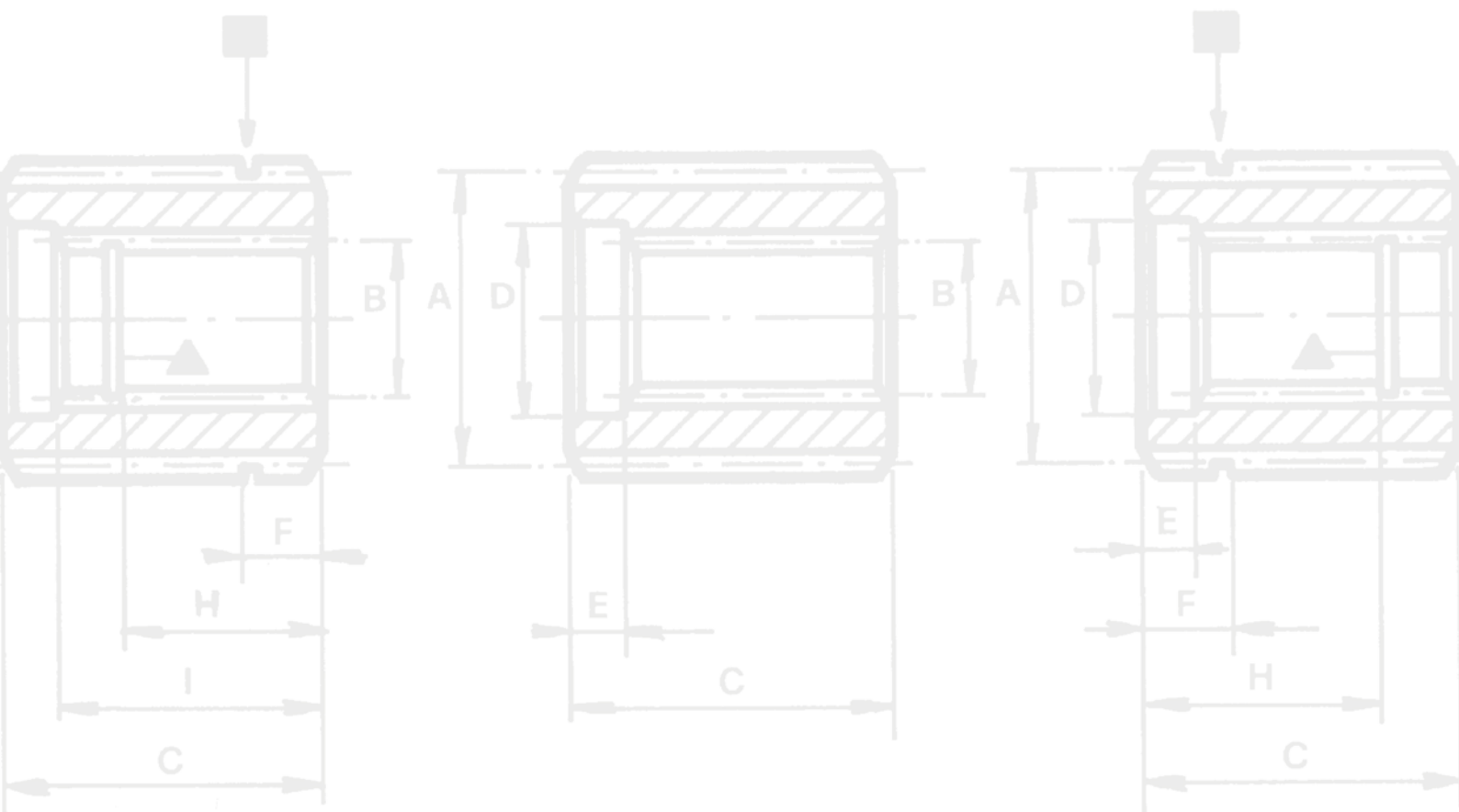

Splined half-couplings, bars, couplings and chain couplings are made of heat-treated steel UNI 16 CrNi4/Pb.

(*) Half-couplings marked with (*) are made of hardened and tempered steel UNI 38 NiCrMo4/Fb and subjected to nitriding with mechanical resistance $R = 95$ to 105 Kg/mm^2



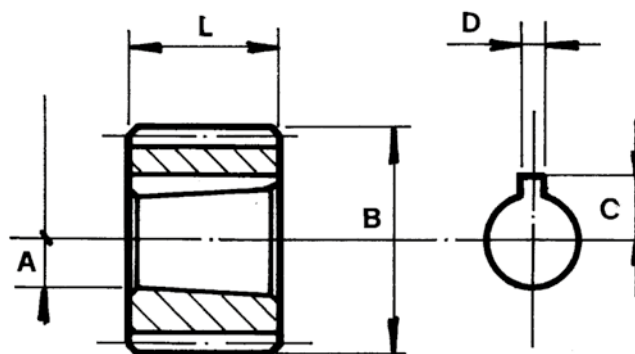

Предназначены для пререхода с конического вала 1:8
на шлицевой профиле DIN 5482

Conicità 1:8 - Conicité 1:8 - Taper ratio 1:8 - Keilneigung 1:8

Codice Code Code No. Codenummer	Tipo pompa Type Pompe Pump type Pumpentype	Gruppo pompa Groupe pompe Pump assembly Pumpenaggregate	Profilo DIN 5482 B Profil DIN 5482 B1 Profile DIN 5482 B Profil nach DIN 5482B	N° Denti Nb. Dents No. of teeth Anzahl Zähne	A	B	C	D	L
10001	1	1	20 × 17	12	8	19,5	5,7	2,4	14,5
10002	0,5	2/0,5	20 × 17	12	6	19,5	4	2	7
10003	1	2/1	25 × 22	14	8	24,5	5,7	2,4	14,5
10004	0,5	2/1	25 × 22	14	6	24,5	4	2	9
10033	1 MARZOCCHI	2/1	25 × 22	14	12	24,5	8,5	3	16
*10005	2	2	25 × 22	14	14,2	24,5	9,3	3,17	22
*10026	2 TUROLLA	2	25 × 22	14	14,5	24,5	9,1	4	22,5
10007	2	2	28 × 25	15	14,2	27,5	9,7	3,17	22
10035	2	2	28 × 25	15	14,5	27,5	9,7	4	22,5
10036	1	2,5/1	32 × 28	17	8	31,5	5,7	2,4	14,5
10039	1 MARZOCCHI	2,5/1	32 × 28	17	12	31,5	8,5	3	16
10008	2	2,5/2	32 × 28	17	14,2	31,5	9,7	3,17	22
10040	2 TUROLLA	2,5/2	32 × 28	17	14,5	31,5	9,7	4	22,5
10009	2,5	2,5	32 × 28	17	18,7	31,5	11,6	4	26
10010	1	3/1	35 × 31	18	8	34,5	5,7	2,4	14,5
10043	1 MARZOCCHI	3/1	35 × 31	18	12	34,5	8,5	3	16
10012	2	3/2	35 × 31	18	14,2	34,5	9,7	3,17	22
10044	2 TUROLLA	3/2	35 × 31	18	14,5	34,5	9,7	4	22,5
*10014	3	3	35 × 31	18	18,7	34,5	12,5	4	26
10046	1	3,5/1	35 × 31	20	8	39,5	5,7	2,4	14,5
10049	1 A RICHIESTA	3,5/1	40 × 36	20	9,7	39,5	6,7	3	16
10050	1 MARZOCCHI	3,5/1	40 × 36	20	12	39,5	8,5	3	16
10015	2	3,5/2	40 × 36	20	14,2	39,5	9,7	3,17	22
10051	2 TUROLLA	3,5/2	40 × 36	20	14,5	39,5	9,7	4	22,5
10016	3	3,5/3	40 × 36	20	18,7	39,5	12,5	4	26
10017	3,5	3,5	40 × 36	20	21,2	39,5	15,1	4,76	32
10052	3,5 TUROLLA	3,5	40 × 36	20	23,7	39,5	15	6	38

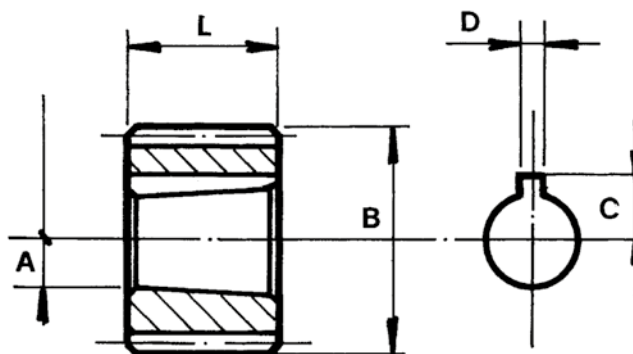

Предназначены для пререхода с конического вала 1:8
на шлицевой профиль DIN 5482

Conicità 1:8 - Conicité 1:8 - Taper ratio 1:8 - Keilneigung 1:8

Codice Code Code No. Codenummer	Tipo pompa Type Pompe Pump type Pumpentype	Gruppo pompa Groupe pompe Pump assembly Pumpenaggregate	Profilo DIN 5482 B Profil DIN 5482 B1 Profile DIN 5482 B Profil nach DIN 5482B	N° Denti Nb. Dents No. of teeth Anzahl Zähne	A	B	C	D	L
10023	1	4/1	48 × 44	23	8	47,5	5,7	2,4	14,5
10055	1 Marzocchi	4/1	48 × 44	23	12	47,5	8,5	3	16
10018	2	4/2	48 × 44	23	14,2	47,5	9,7	3,17	22
10056	2 Turolla	4/2	48 × 44	23	14,5	47,5	9,7	4	22,5
10019	3	4/3	48 × 44	23	18,7	47,5	12,5	4	26
10020	3,5	4/3,5	48 × 44	23	21,2	47,5	15,1	4,76	32
10057	3,5 Marzocchi	4/3,5	48 × 44	23	21,2	47,5	15,1	5	32
10058	3,5 Turolla	4/3,5	48 × 44	23	23,7	47,5	15	6	38
10021	4	4	48 × 44	23	27,7	47,5	18,7	6,35	42
10059	4 Marzocchi	4	48 × 44	23	27,7	47,5	19,4	7	42
10060	2	5/2	58 × 53	27	14,2	57,5	9,7	3,17	22
10061	2 Turolla	5/2	58 × 53	27	14,5	57,5	9,7	4	22,5
10062	3	5/3	58 × 53	27	18,7	57,5	12,5	4	26
10063	3,5	5/3,5	58 × 53	27	21,2	57,5	15,1	4,76	32
10064	3,5 Marzocchi	5/3,5	58 × 53	27	21,2	57,5	15,1	5	32
10065	3,5 Turolla	5/3,5	58 × 53	27	23,7	57,5	15	6	38
10066	4	5/4	58 × 53	27	27,7	57,5	18,7	6,35	42
10067	4 Marzocchi	5/4	58 × 53	27	27,7	57,5	19,4	7	42
10068	2	6/2	72 × 66	33	14,2	71,3	9,7	3,17	22
10069	2 Turolla	6/2	72 × 66	33	14,5	71,3	9,7	4	22,5
10070	3	6/3	72 × 66	33	18,7	71,3	12,5	4	26
10071	3,5	6/3,5	72 × 66	33	21,2	71,3	15,1	4,76	32
10072	4	6/4	72 × 66	33	27,7	71,3	18,7	6,35	42
10073	3	7/3	80 × 74	36	18,7	79,3	12,5	4	26
10074	3,5	7/3,5	80 × 74	36	21,2	79,3	15,1	4,76	32
10075	4	7/4	60 × 74	36	27,7	79,3	18,7	6,35	42
10076	3	8/3	100 × 94	44	18,7	99,3	12,5	4	26
10077	3,5	8/3,5	100 × 94	44	21,2	99,3	15,1	4,76	32
10078	4	8/4	100 × 94	44	27,7	99,3	18,7	6,35	42

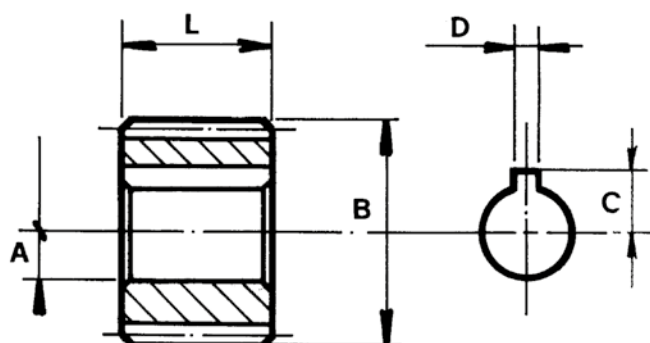

Для пререхода с цилиндрического вала
на шлицевой профиль DIN 5482

Foro cilindrico - Trou cylindrique - Cylindrical bore - Zylinderbohrung

Codice Code Code No. Codenummer	Tipo pompa Type Pompe Pump type Pumpentype	Gruppo pompa Groupe pompe Pump assembly Pumpenaggregate	Profilo DIN 5482 B Profil DIN 5482 B1 Profile DIN 5482 B Profil nach DIN 5482B	N° Denti Nb. Dents No. of teeth Anzahl Zähne	A	B	C	D	L
10027	0,5	1/0,5	20 × 17	12	6	19,5	4	2	9
10028	9,5 Turolla	1/0,6	20 × 17	12	7	19,5	4,6	2	9
10029	1	1	20 × 17	12	12	19,5	7,6	3	13,5
10030	0,5	2/0,5	25 × 22	14	6	24,5	4	2	9
10031	0,5	2/0,6	25 × 22	14	7	24,5	4,6	2	9
10032	1	2/1	25 × 22	14	12	24,5	7,6	3	13,5
10034	2	2	25 × 22	14	15	24,5	8,4	4	31
10037	1	2.5/1	32 × 28	17	12	31,5	7,6	3	13,5
10041	3	2,5/3	32 × 28	17	20	31,5	11,8	5	41
10042	1	3/1	35 × 31	18	12	34,5	7,6	3	13,5
10045	2	3/2	35 × 31	18	15	34,5	9,2	4	31
10047	3	3	35 × 31	18	20	34,5	11,8	5	41
10048	1	3,5/1	40 × 36	20	12	39,5	7,6	3	13,5
10053	1	4/1	48 × 44	23	12	47,5	7,6	3	13,5

Предназначены для пререхода с конического вала 1:5
на шлицевой профиль DIN 5482

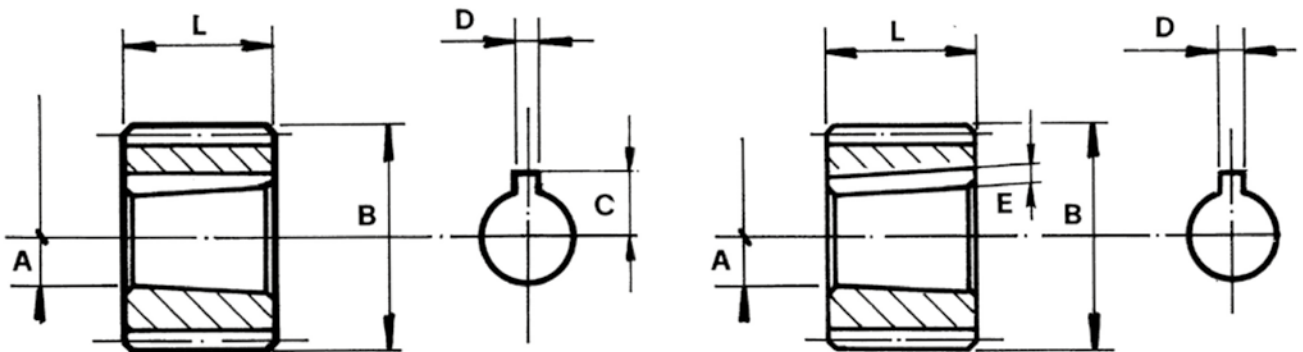

Conicità 1:5 - Conicité 1:5 - Taper ratio 1:5 - Keilneigung 1:5

N° Codice Code Code No. Codenummer	Tipo pompa Type Pompe Pump type Pumptypetype	Gruppo pompa Groupe pompe Pump assembly Pumpenaggregate	Profilo DIN 5482 B Profil DIN 5482 B1 Profilie DIN 5482 B Profil nach DIN 5482B	N° Denti Nb. Dents No. of teeth Anzahl Zähne	A	B	C	D	E	L
10501	A	1	20 × 17	12	7,6	19,5		2	1	12
10502	A	2/1	25 × 22	14	8	24,5		2	1	10
*10503	B	2	25 × 22	14	13	24,5	9,2	3		20
10504	B	2	28 × 25	15	13	27,5		3	1,9	20
10505	A	2,5/1	32 × 28	17	8	31,5		2	1,9	20
10506	B	2,5/2	32 × 28	17	13,2	31,5		3	1,9	20
10518	C	2,5	32 × 28	17	15,2	31,5		4	2,1	24
10507	B	3/2	35 × 31	18	13	34,5		3	1,9	20
*10508	D	3	35 × 31	18	19,6	34,5	13,7	5		25
10509	B	3,5/2	40 × 36	20	13,2	39,5		3	1,9	20
10510	C	3,5/2,5	40 × 36	20	15,2	39,5		4	2,1	24
10519	D	3,5/3	40 × 36	20	19,6	39,5		5	2,5	25
10511	B	4/2	48 × 44	23	13,2	47,5		3	1,9	20
10512	C	4/2,5	48 × 44	23	15,2	47,5		4	2,1	24
10513	D	4/3	48 × 44	23	19,6	47,5		5	2,5	25
10514	Gruppo 4	4	48 × 44	23	24	47,5		6	2,5	32
10520	B	5/2	58 × 53	27	13,2	57,5		3	1,9	20
10515	C	5/2,5	58 × 53	27	15,2	57,5		4	2,1	24
10516	D	5/3	58 × 53	27	19,6	57,5		5	2,5	25
10521	Gruppo 4	5/4	58 × 53	27	23,6	57,5		6	2,5	32
10517	D	6/3	72 × 66	33	19,6	71,3		5	2,5	25
10522	Gruppo 4	6/4	72 × 66	33	23,6	71,3		6	2,5	32
10523	D	7/3	80 × 74	36	19,6	79,3		%	2,5	25
10524	Gruppo 4	7/4	80 × 74	36	23,6	79,3		6	2,5	32

	BOSCH	KRACHT	HPI
A	HY/ZBR/1. HY/ZBS...	KP02/FK	
B	HY/ZFS.... HY/ZFS...204	KP12/FK K12/FL	KP12/GK 2000 CB1
C	HY/KVE.... HY/MZFR....	HY/ZFR/2.... HY/ZFBR/2	
D	HY/ZGFS.... HY/MZGS....	HY/ZGR.... HY/ZGS....	KP22/FL 3000 DB1 3000 CB1

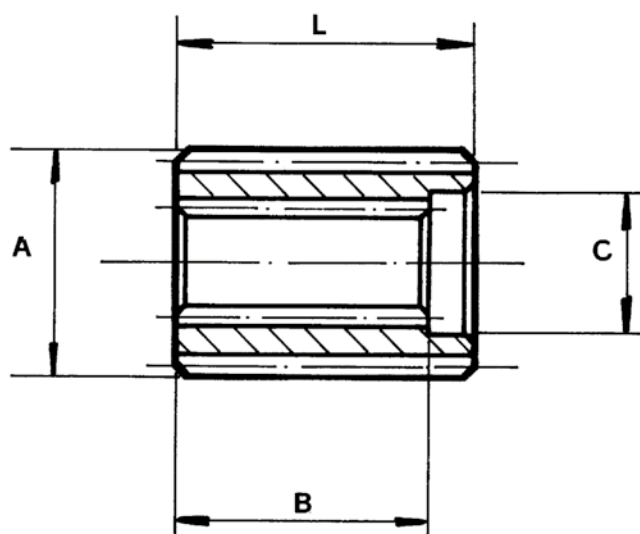

Предназначены для пререхода со шлицевого профиля вала DIN 5482A на шлицевой профиль DIN 5482

N° Codice Code Code No. Codenummer	Tipo pompa Type Pompe Pump type Pumpentype	Profilo esterno DIN 5482A Profil externe DIN 5482A External profile DIN 5482A Innenprofil nach DIN 5482A	N° Denti Nb. Dents No. of teeth Anzahl Zähne	Profilo interno DIN 5482B Profil interne DIN 5482B Internal profile DIN 5482B Aussenprofil nach DIN 5482B	N° Denti Nb. Dents No. of teeth Anzahl Zähne	A	B	C	L
13001	20-35	48 × 44	23	25 × 22	14	47,5	35	25	40
13002	50	48 × 44	23	30 × 27	16	47,5	38	30,5	43
13003	75	48 × 44	23	35 × 31	18	47,5	42	35,5	46
13004	50	58 × 53	27	30 × 27	16	57,5	38	30,5	43
13005	75	58 × 53	27	35 × 31	18	57,5	42	35,5	46
13006	105	58 × 53	27	40 × 36	20	57,5	47	40,5	52
13007	140	58 × 53	27	45 × 41	22	57,5	56	45	62
13008	105	72 × 66	33	40 × 36	20	71,3	47	40,5	52
13009	140	72 × 66	33	45 × 41	22	71,3	56	45	62
13010	186	72 × 66	33	50 × 45	24	71,3	61	50	68

СЕРИЯ 35000 СТАНДАРТ DIN 5482
СЕРИЯ 35500 СТАНДАРТ SAE

СЕРИЯ 35000А СТАНДАРТ DIN 5482
СЕРИЯ 35500А СТАНДАРТ SAE

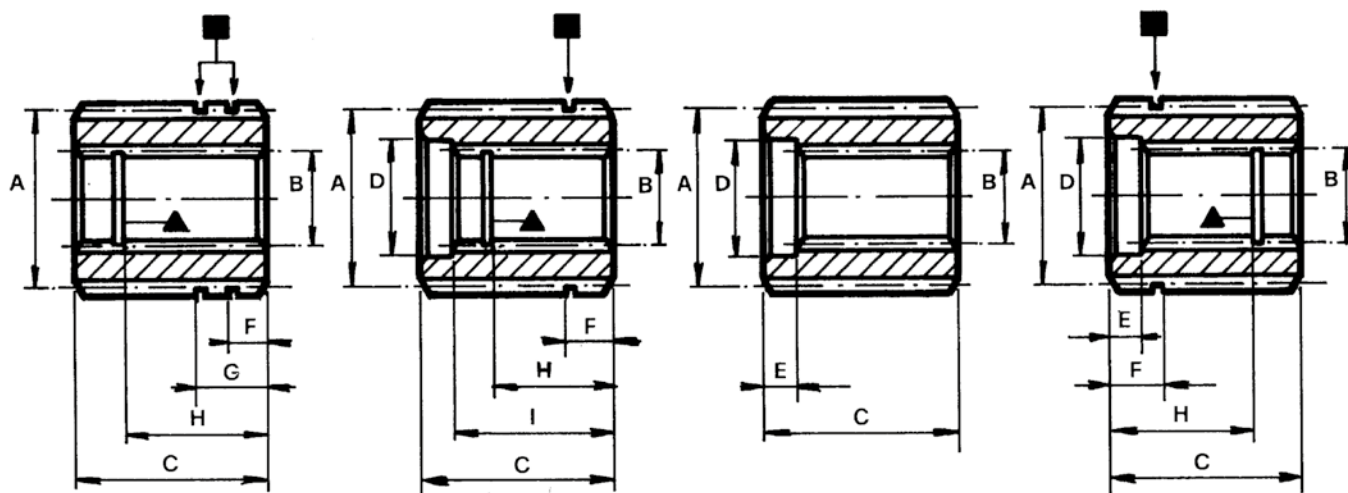

Gruppo Tipo	N° Codice	A		B		B		C	D	E	F	G	H	I	▲	■
		Code	N. denti	N. denti	N. denti	Code	N. denti									
Assembley type	Code No.	DIN 5482	Nb. dents	DIN 5482	Nb. dents	SAE	Nb. dents									
Gruppe, Type	Codenummer		No. of teeth		No. of teeth		No. of teeth									
			Anz. Zähne		Anz. Zähne		Anz. Zähne									
3	C	35001	35 × 31	18	25 × 22	14		26								
3,5	C	35002	40 × 36	20	30 × 27	16		43	30,5	5						
4	C	35003	48 × 44	23	25 × 22	14		40	25	5						
4	C	35004	48 × 44	23	30 × 27	16		43	30,5	5						
4	C	35005	48 × 44	23	35 × 31	18		44	35,5	2						
5	C	35006	58 × 53	27	30 × 27	16		43	30,5	5						
5	C	35007	58 × 53	27	35 × 31	18		46	35,5	4						
5	C	35008	58 × 53	27	40 × 36	20		52	40,5	5						
5	C	35009	58 × 53	27	45 × 41	22		62	34	6						
6	C	35010	72 × 66	33	40 × 36	20		52	40,5	5						
6	C	35011	72 × 66	33	45 × 41	22		62	45	6						
6	C	35012	72 × 66	33	50 × 45	24		68	50	7						

3	A	35501	35 × 31	18			16/32''DP	13	35			5				34	
3	B	35502	35 × 31	18			16/32''DP	15	40	26		7		32	35	22	34
3,5	A	35503	40 × 36	20			16/32''DP	13	35			5					40
3,5	B	35504	40 × 36	20			16/32''DP	15	40	26		7		32	35	22	40
4	D	35505	48 × 44	23			16/32''DP	13	46	23	10	3,5		41,5		19	48
4	B	35506	48 × 44	23			16/32''DP	15	40	26		7		32	35	22	48
4	A	35507	48 × 44	23			16/32''DP	21	50			6	20	40		32	48
4	D	35508	48 × 44	23			12/24''DP	14	49	32,5	8	8	16	45,2		28	48
5	B	35509	58 × 53	27			16/32''DP	21	73	38		30		40	47	32	58
5	B	35510	58 × 53	27			16/32''DP	23	72	40		30		41	46	35	58
5	D	35511	58 × 53	27			12/24''DP	14	49	32,5	8	8		45,2		28	58

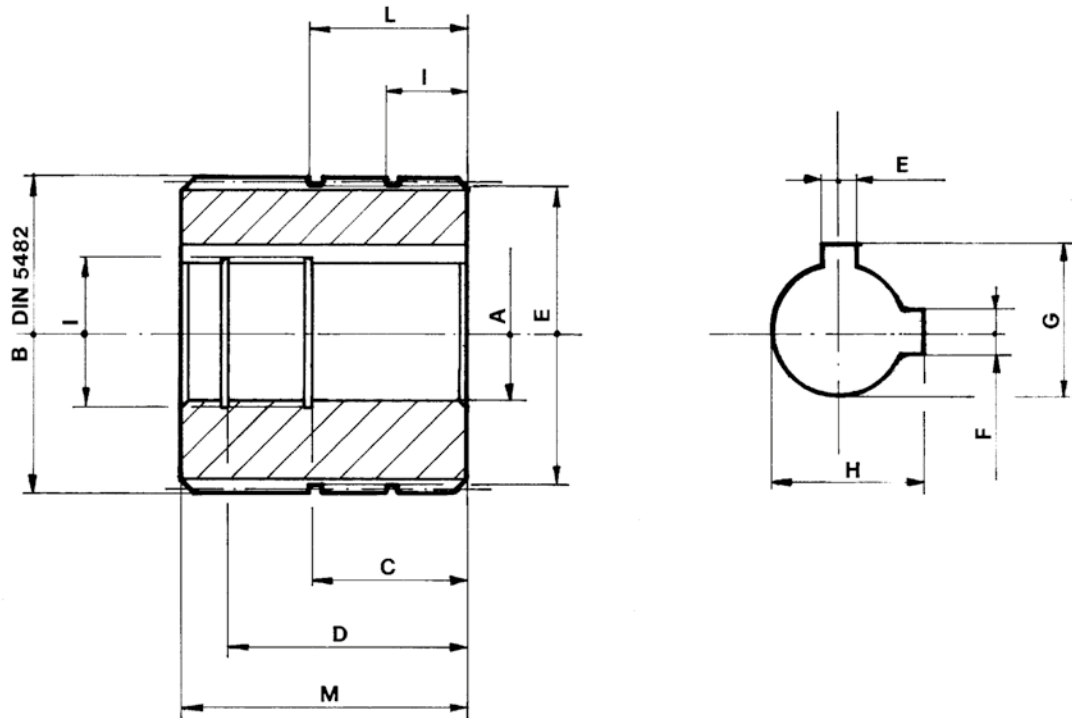

N° Codice Code Code No. Codenummer	Gruppo pompa Groupe Pump Pump assembly Pumpen- aggregate	Profilo Profil Profile Profil	N° Denti N. Dents No. of teeth Anzahl Zähne	I ∅	E ∅	A	B	C	D	E	F	G	H	I	L	M
15001	A	35 × 31	18	19	34	19,05	34,5	26	41	4,8		21,2		13	27	48
15002	B-C	35 × 31	18	22	34	22,22	34,5	26	40	4,8	6,4	24,5	25,2	14	27	48
15003	A	40 × 36	20	19	40	19,05	39,5	23	36	4,8		21,2		9	13	41
15004	B-C	40 × 36	20	22	40	22,22	39,5		32	4,8	6,4	24,5	25,2	4	10	45
15005	A	48 × 44	23	22	48	19,05	47,5	26	40	4,8		21,2		8	25	49
15006	B-C	48 × 44	23	22	48	22,22	47,5	26	42	4,8	6,4	24,5	25,2	8	25	50
15007	D-E	48 × 44	23	32	48	31,75	47,5	41	55	6,4	8	34,6	35,3	8	20,5	60
15008	B-C	58 × 53	27	22	58	22,22	57,5	26	42	4,8	6,4	24,5	25,2	8	25	50
15009	D-E	58 × 53	27	32	58	31,75	57,5	41	55	6,4	8	34,6	35,3	8	20,5	60

Marca pompa Marque pompe Pump make Pumpenhersteller	A	B	C	D	E
VICKERS	V100 V200	25V 30V	PVB 10		35V 45V
VICKERS	V10 V20		PVB 15		PVB 20/29
VICKERS	PFB 5/6		PFB 10		PFB 20/29
VICKERS	PVB 5/6				
DENISON	TMB	T3B	T3CB	T2D TDC	
DENISON		T1C		TDCB	

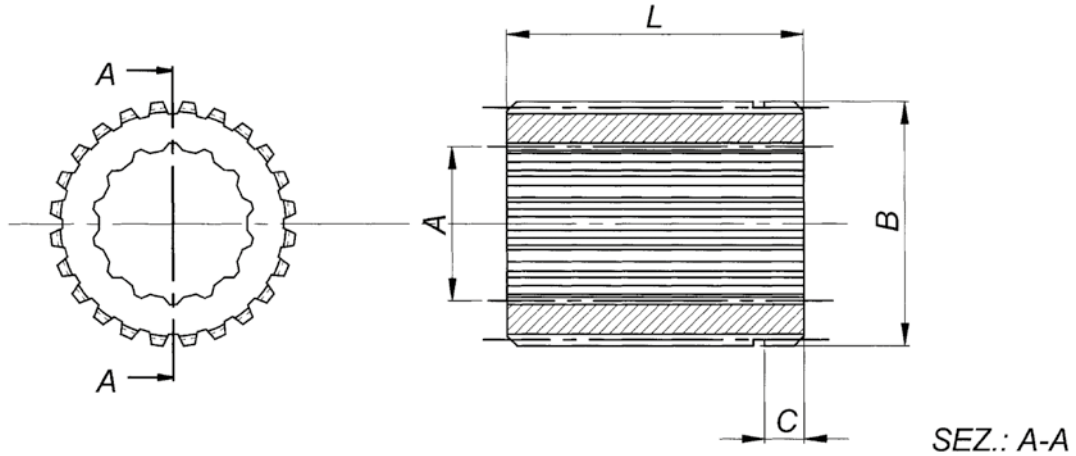

Codice Code Code No. Codenummer	N°denti esterni Nb.Dents externe No.of teeth exterior Anzal Zahne extern	Scanalato esterno : B Cannelè esterieur : B Splined shaft exterior : B Auskehlung innere extern : B	N°denti interni Nb.Dents interiere No.of teeth inside Anzal Zahne innere	Scanalato interno : A Cannelè interieur : A Splined shaft : A Auskehlung innere : A	L	C
34200	20	B 40x36 - DIN 5482	14	12/24" DP	40	5
34201	20	B' 40x36 - DIN 5482	14	W30x2x14x9 H DIN 5480	40	5
34300	24	B 50x45 - DIN 5482	14	W30x2x14x9H DIN 5480	40	8
34301	24	B 50x45 - DIN 5482	16	W35x2x16x9H DIN 5480	40	8
34302	24	B 50x45 - DIN 5482	18	W40x2x18x9H DIN 5480	40	8
34400	24	B 50x45 - DIN 5482	9	16/32" DP	40	8
34401	24	B 50x45 - DIN 5482	11	16/32" DP	40	8
34402	24	B 50x45 - DIN 5482	13	16/32" DP	40	8
34403	24	B 50x45 - DIN 5482	15	16/32" DP	40	8
34404	24	B 50x45 - DIN 5482	21	16/32" DP	48	8
34405	24	B 50x45 - DIN 5482	23	16/32" DP	48	8
34406	24	B 50x45 - DIN 5482	14	12/24" DP	40	8
35512	18	B 35x31 - DIN 5482	11	16/32" DP	40	5
35513	18	B 35x31 - DIN 5482	9	16/32" DP	45	5
35514	14	B 25x22 - DIN 5482	9	16/32" DP	20	5
35516	23	B 48x44 - DIN 5482	23	16/32" DP	50	5
35517	14	B 25x22 - DIN 5482	9	16/32" DP	30	5
35519	18	B 35x31 - DIN 5482	9	16/32" DP	40	5

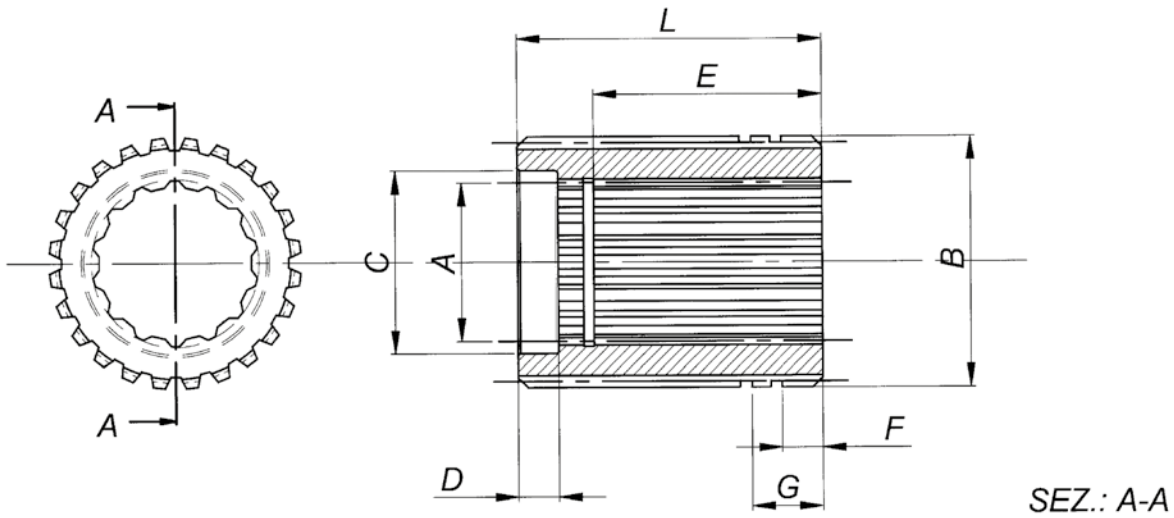

Codice Code Code No. Codenummer	N°denti esterni Nb.Dents externe No.of teeth exterior Anzal Zahne extern	Scanalato esterno : B Cannelè esterieur : B Splined shaft exterior : B Auskehlung innere extern : B	N°denti interni Nb.Dents interiere No.of teeth inside Anzal Zahne innere	Scanalato interno : A Cannelè interieur : A Splined shaft : A Auskehlung innere : A	L	C	D	E	F	G
35550	18	B 35x31 - DIN 5482	18	N 25x1.25x18x11 H DIN 5480	50				5	13
35551	23	B 48x44 - DIN 5482	18	N 25x1.25x18x11 H DIN 5480	48				5	13
35552	23	B 48x44 - DIN 5482	14	N 30x2x14x11 H DIN 5480	48				6	18
35553	23	B 48x44 - DIN 5482	16	N 35x2x16x11 H DIN 5480	50	38	6	40	6	18
35554	27	B 58x53 - DIN 5482	16	N 35x2x16x11 H DIN 5480	49	36	8	43	5	
35555	27	B 58x53 - DIN 5482	18	N 40x2x18x11 H DIN 5480	52	41	8	48	6	
35556	20	B 40x36 - DIN 5482	18	N25x1.25x18x11 H DIN 5480					3	

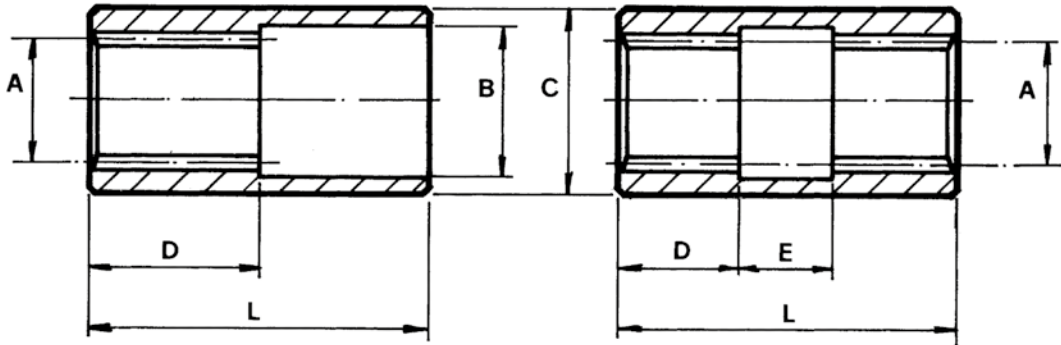

Codice Code Code No. Codenummer	Gruppo pompa Groupe Pompe Pump assembly Pumpenaggregate	Profilo Profil Profil Profil	N° Denti Nb. Dents No. of teeth Anzahl Zähne	A	B	C	D	E	L
10201	1	20 x 17 DIN 5482	12	17	20,5	25	25		50
10202	2	25 x 22 DIN 5482	14	22	25,5	32	30		60
10203	2	28 x 25 DIN 5482	15	25	28,5	34	30		60
10204	2,5	32 x 28 DIN 5482	17	28	33,5	39	30		60
10205	3	35 x 31 DIN 5482	18	31	35,5	42	30		60
10206	3,5	40 x 36 DIN 5482	20	36	40,5	49,5	33		66
10207	4	48 x 44 DIN 5482	23	44	48,5	62	42		90
10208	2 Doppio	25 x 22 DIN 5482	14	22		32	20	20	60
10209	3 Doppio	35 x 31 DIN 5482	18	31		44	29,5	12	71
10300		W25 x 1,25 x 18 x 9H DIN 5480	18		25,5	32	30		60
10301		W30 x 2 x 14 x 9H DIN 5480	14		30,5	38	30		60
10302		W35 x 2 x 16 x 9H DIN 5480	16		35,5	42	30		60
10303		W40 x 2 x 18 x 9H DIN 5480	18		40,5	49,5	33		66
10401		16/32'' DP	13		23	30	25		50
10402		16/32'' DP	15		26	32	30		60
10403		16/32'' DP	21		35,5	42	30		60
10404		16/32'' DP	23		38,5	49	33		66
10405		12/24'' DP	12		28,5	34	30		60
10406		12/24'' DP	14		32,5	39	30		60

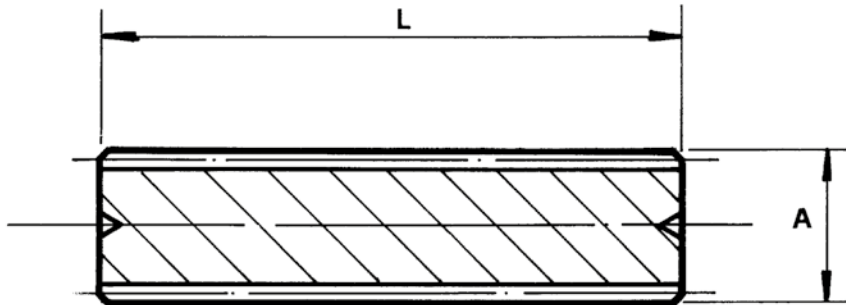

Dentature tipo DIN 5482B - Dentures Type DIN 5482B - Tothing type DIN 5482B - Verzahnungstype nach DIN 5482B

N° Codice Code Code No. Codenummer	Profilo Profil Profil Profil	Numero Denti Nb. Dents No. of teeth Anzahl Zähne	A	L
14001	20 × 17	12	19,5	300
14002	22 × 19	13	21,5	300
14003	25 × 22	14	24,5	300
14004	28 × 25	15	27,5	300
14005	30 × 27	16	29,5	300
14006	32 × 28	17	31,5	300
14007	35 × 31	18	34,5	300
14008	40 × 36	20	39,5	300
14009	45 × 41	22	44,5	300
14010	48 × 44	23	47,5	300
14011	50 × 45	24	49,5	300
14012	58 × 53	27	57,5	300
14013	60 × 55	28	59,5	300
14014	70 × 64	32	69,5	300
14015	72 × 66	33	71,5	300
14016	80 × 74	36	79,5	300
14017	100 × 94	44	99,5	300

N.B.: Si possono costruire anche barre scanalate secondo profili SAE 16/32" 12/24" e DIN 5480.

N.B.: Des barres cannelées suivant profils SAE 16/32" 12/24" et DIN 5480 peuvent être construites.

N.B.: Splined bars can also be supplied as per SAE 16/32" - 12/24" and DIN 5480 profile.

N.B.: Es können auch genutete stangen geliefert werden nach Profil SAE 16/32" - 12/24" und DIN 5480.

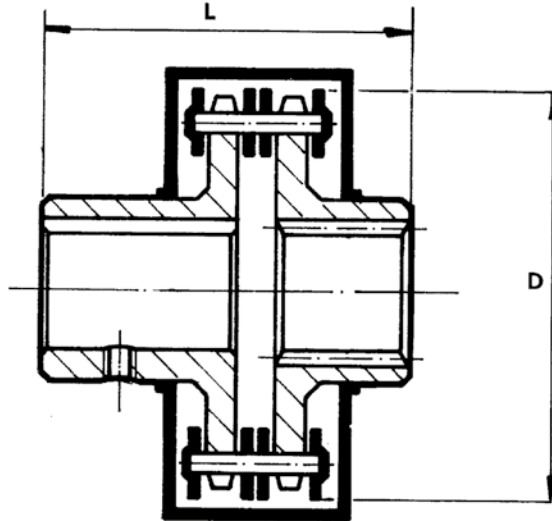

Coppia max trasmissibile a 1500 g/1' Disassamento angolare max. 2°
 Couple maxi. transmissible à 1500 tours/min. Désaxement angulaire 2° maxi.
 Max transmissible torque at 1500 r.p.m. Max angular misalignment 2°
 Max. übertragbares Drehmoment bei 1500/min-1. Achsversetzung max 2°

Giunto completo N° Codice	Semigiunto scanalato N° Codice	Semigiunto motore N° Codice	Catena N° Codice	Maglia di giunzione N° Codice	Protezione N° Codice	HP	D	L
Accouplement complet Code	Demi-accouplement canneles Code	Demi-accouplement moteur Code	Chaîne Code	Mailion de jonction Code	Protection Code			
Complete coupling Code No.	Splined half-coupling Code No.	Engine half-coupling Code No.	Chain Code No.	Link Code No.	Guard Code No.			
Komplette Kupplung Codenummer	Genutete Halbkupplungen Codenummer	Halbkupplungen Motoren Codenummer	Kette Codenummer	Verbindungsglied Codenummer	Schutz Codenummer			
16801 C14	16001	16201	16406	12503	12604	0,37	57	57,2
16802 C19	16001	16202	12406	12503	12604	0,75	57	67,2
16803 C24/L	16001	16203	12406	12503	12604	1,1	57	67,2
16804 C24/P	16002	16204	12407	12501	12605	1,5	69	84,9
16805 C28	16003	16205	12408	12501	12606	4	77	99,9
16806 C32	16003	16206	12408	12501	12606	5	77	122
16807 C38/L	16004	16207	12409	12501	12607	5,5	85	131,9
16808 C38/P	16005	16208	12410	12502	12608	7,5	102	133,5
16809 C42/L	16004	16209	12409	12501	12607	11	85	156,9
16810 C42/P	16005	16210	12410	12502	12608	15	102	158,5
16811 C48/L	16006	16211	12411	12501	12602	18,5	89	156,9
16812 C48/P	16007	16212	12412	12502	12609	22	114	158,5
16813 C48/PI	16008	16212	12412	12502	12609	22	114	158,5
16814 C55	16007	16213	12412	12502	12609	30	114	158,5
16815 C55/I	16008	16213	12412	12502	12609	30	114	158,5
16816 C60	16009	16214	12404	12502	12603	37	138	183,5
16817 C60/1	16010	16214	12404	12502	12603	37	138	183,5
16818 C60/2	16011	16214	12404	12502	12603	45	138	183,5
16819 C65	16009	16215	12404	12502	12603	55	138	203,5
16820 C65/I	16010	16215	12404	12502	12603	55	138	203,5
16821 C65/2	16011	16215	12404	12502	12603	55	138	203,5
16822 C75	16012	16216	12405	12502	12610	75	162	203,5
16823 C75/I	16013	16216	12405	12502	12610	75	162	203,5
16824 C75/2	16014	16216	12405	12502	12610	90	162	203,5
16825 C80	16015	16217	12413	12504	12611	132	167	216,1

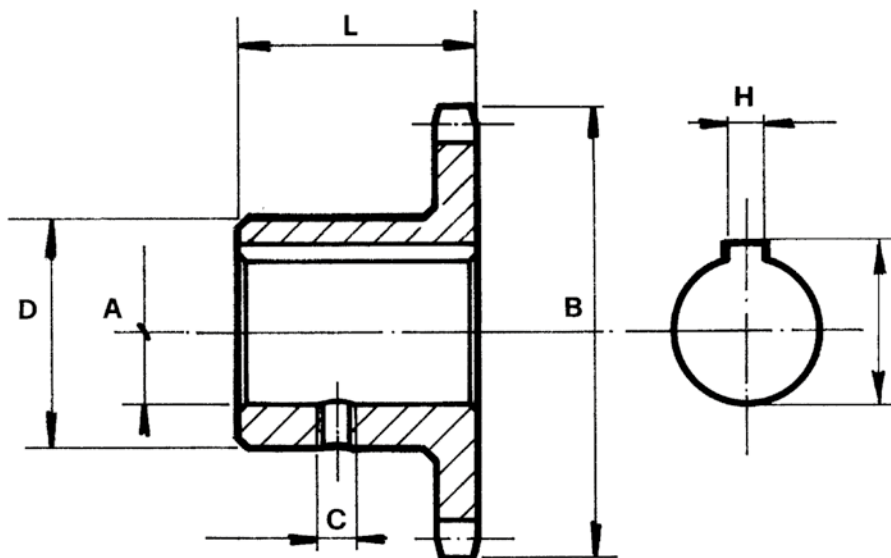

N° Codice Code Code No. Codenummer	Dati dentatura Données denture Type of toothing Verzahnung, Techn. Daten		A	B	C	D	H	I	L
	Passo Pas Pitch Steigung	N. Denti Nb. Dents No. of teeth Anz. Zähne							
16201	3/8"	16	14	53,6	M8	38	5	16,1	30
16202	3/8"	16	19	53,6	M8	38	6	21,6	40
16203	3/8"	16	24	53,6	M8	38	8	27,1	40
16204	1/2"	14	24	63,26	M8	41	8	27,1	50
16205	1/2"	16	28	70	M10	48	8	31,1	65
16206	1/2"	16	32	70	M10	48	10	35,3	87
16207	1/2"	18	38	78,5	M10	60	10	41,6	85
16208	3/4"	14	38	94,8	M10	64	10	41,6	85
16209	1/2"	18	42	78,5	M10	60	12	45,6	110
16210	3/4"	14	42	94,8	M10	64	12	45,6	110
16211	1/2"	19	48	83,7	M12	64	14	52,1	110
16212	3/4"	16	48	107,2	M12	74	14	52,1	110
16213	3/4"	16	55	107,2	M12	74	16	60,1	110
16214	3/4"	20	60	131,7	M14	94	18	65,1	125
16215	3/4"	20	65	131,7	M14	94	18	70,1	145
16216	3/4"	24	75	156,12	M16	120	20	81,3	145
16217	1"	18	80	157,2	M16	117	22	87,2	150

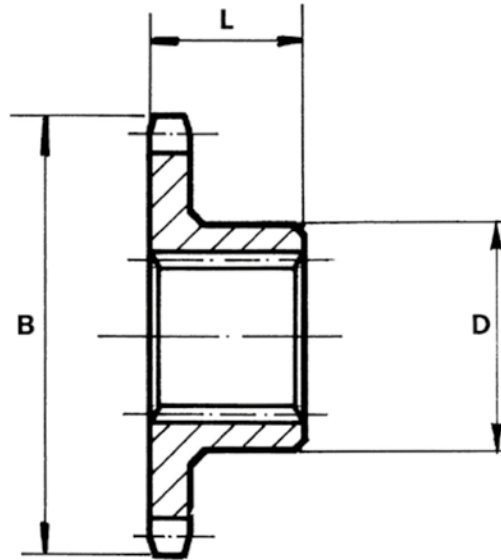

N° Codice Code Code No. Codenummer	Dentatura esterna Denture extérieure External toothing Aussenverzahnung		Dentatura interna Denture intérieure Internal toothing Innenverzahnung		B	D	L
	Profilo Profil Profile Profil	N° Denti Nb. dents No. of teeth Anz. Zähne	Profilo Profil Profile Profil	N° Denti Nb. dents No. of teeth Anz. Zähne			
16001	3/8"	16	25 × 22	14	53,6	38	22
16002	1/2"	14	35 × 31	18	63,26	41	28
16003	1/2"	16	35 × 31	18	70	47	28
16004	1/2"	18	48 × 44	23	78,5	60	40
16005	3/4"	14	48 × 44	23	94,8	64	40
16006	1/2"	19	48 × 44	23	83,7	64	40
16007	3/4"	16	48 × 44	23	107,2	74	40
16008	3/4"	16	58 × 53	27	107,2	74	40
A RICHIESTA	3/4"	16	72 × 66	33	107,2	80,5	40
16009	3/4"	20	48 × 44	23	131,7	94	50
16010	3/4"	20	58 × 53	27	131,7	94	50
16011	3/4"	20	72 × 66	33	131,7	94	50
16012	3/4"	24	48 × 44	23	156,12	120	50
16013	3/4"	24	58 × 53	27	156,12	120	50
16014	3/4"	24	72 × 66	33	156,12	120	50
16015	1"	18	72 × 66	33	157,2	115	50

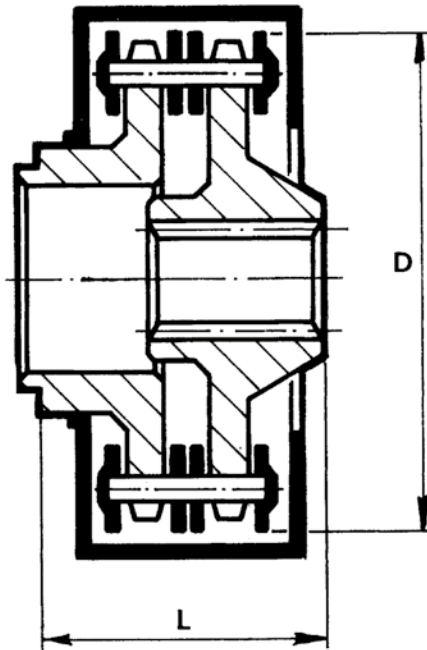

Coppia max. a 2500 g/min. - Couple maxi. à 2500 tours/min. - Max. torque at 2500 r.p.m.
 Max. Drehmoment bei 2500 /min.⁻¹

Giunto completo N° Codice Accouplement complet Code Complete coupling Code No. Komplette Kupplung Codenummer	Semigiunto centralina N° Codice Demi-accouplement distributeur Code Gearbox half-coupling Code No. Halbkupplung Steuereinheit Codenummer	Semigiunto porta-flangia N° Codice Porte-bride Code Flange half-coupling Code No. Halbkupplung Flanschhalter Codenummer	Catena N° Codice Chaîne Code Chain Code No. Kette Codenummer	Maglia di giunzione N° Codice Maillon de jonction Code Link Code No. Verbindungsglied Codenummer	Protezione N° Codice Protection Code Guard Code No. Schutz Codenummer	D	L	Kgm	HP
12801	12005	12201	12401	12501	12600	101	53	15	52
12802	12001	12202	12402	12501	12601	109	48	18,5	64
12803	12002	12202	12402	12501	12601	109	48	18,5	64
12804	12003	12203	12403	12501	12602	134	64	23	80
12805	12004	12204	12404	12502	12603	138	66	30	100
12806	12006	12204	12404	12502	12603	138	66	30	100
12807	12007	12205	12405	12502	12604	162	63	40	135
12808	12008	12205	12405	12502	12604	162	63	40	135

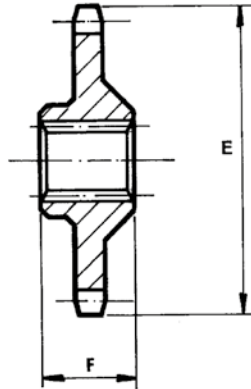

N° Codice Code Code No. Codenummer	Dentatura esterna Denture extérieure External toothing Aussenverzahnung		Dentatura interna Denture Intérieure Internal toothing Innenverzahnung		E	F
	Passo Pas Pitch Steigung	N° Denti Nb. dents No. of teeth Anz. Zähne	Profilo Profil Profile Profil	N° Denti Nb. dents No. of teeth Anz. Zähne		
12005	1/2"	22	35 x 31	18	94,5	27
12001	1/2"	24	32 x 38	17	102,5	27
12002	1/2"	24	35 x 31	18	102,5	27
12003	1/2"	30	48 x 44	23	127	40
12004	3/4"	20	48 x 44	23	130,5	40
12006	3/4"	20	50 x 45	24	130,5	40
12007	3/4"	24	48 x 44	23	156,13	48
12008	3/4"	24	58 x 53	27	156,13	48

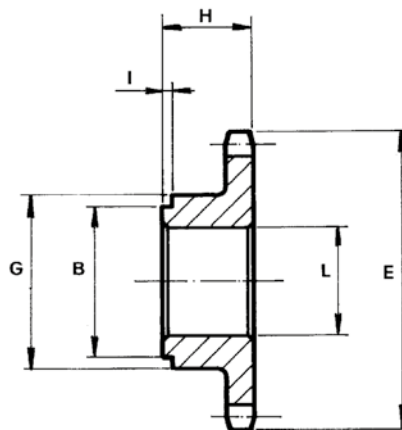

Codice N°. Code Code No. Codenummer	Dentatura esterna Denture extérieure External toothing Aussenverzahnung		G	B	E	H	I	L
	Passo Pas Pitch Steigung	N° denti Nb. dents No. of teeth Anz. Zähne						
12201	1/2"	22	70	68	94,5	23	4	56
12202	1/2"	24	72	68	102,5	27	3	56
12203	1/2"	30	81	74	127	40	3	68
12204	3/4"	20	82	74	130,5	40	3	68
12205	3/4"	24	110	105	156,13	48	5	90

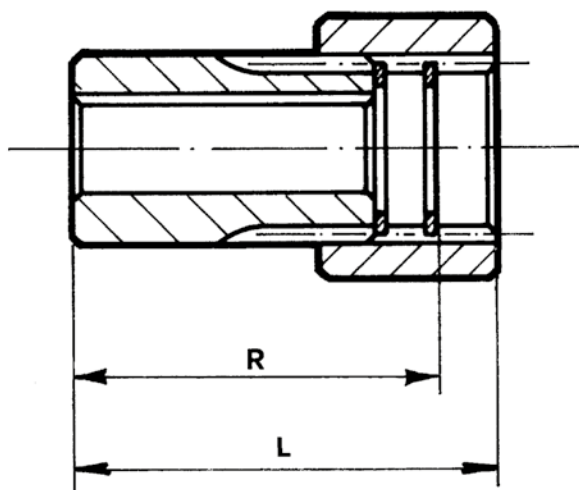

Giunto completo N° Codice Accouplement complet Code Complete coupling Code No. Kopl. Kupplung Codenummer	Semigiunto N° Codice Demi-accouplement Code Half-coupling Code No. Halbkupplung Codenummer	Manicotto N° Codice Manchon Code Sleeve Code No. Muffe Codenummer	Profilo DIN 5482 Profil DIN 5482B Profilo DIN 5482B Profil nach DIN 5482B	N. Denti Nb. dents No. of teeth Anzahl Zähne	L	HP.	Kgm.	R
11401 GN14	11001	11201	32 × 28	17	50	0,5	3	40
11402 GN19	11003				60	1		50
11405 GN24	11005	11205	48 × 44	23	77	2 ÷ 3	11	60
11406 GN28	11006				87	5,5		70
11408 GN38	11008	11208	58 × 53	27	111	7,5 ÷ 12,5	15	93
11409 GN42	11009				141	12,5 ÷ 20		123
11410 GN48	11010	11210	72 × 66	33	146	30	20	123
11411 GN55	11011	11216	80 × 74	36	155	40	25	125
11417 GN60	11017	11217	100 × 94	44	175	45 ÷ 50	30	140
11418 GN65	11018					55 ÷ 60	35	140
11419 GN75	11019					70 ÷ 80	45	140

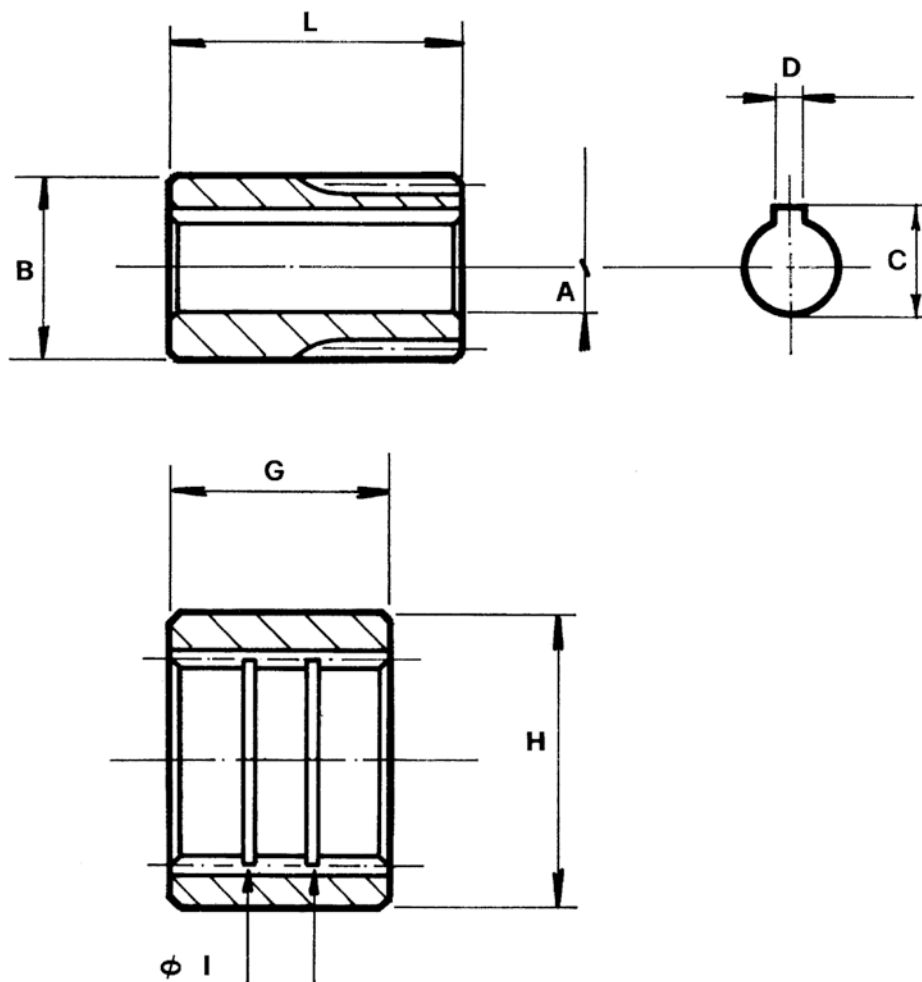

Semigiunto N° Codice	Manicotto N° Codice	Profilo DIN 5482A Profil DIN 5482A Profile DIN 5482A Profil nach DIN 5482A	A	B	C	D	G	H	I	L
Demi-accouplement Code	Manchon Code									
Half-coupling Code No.	Sleeve Code No.									
Halbkupplung Codenummer	Muffe Codenummer									
11001	11201	32 × 28	14	31,5	16,1	5	30	36	28	30
11003			19		21,6	6				40
11005	11205	48 × 44	24	47,5	27	8	44	55	44	50
11006			28		31					60
11008	11208	58 × 53	38	57,5	41,6	10	49	68	53	80
11009			42		64					45,7
11010	11210	72 × 66	48	71,3	52,5	14	59	84	66	110
11011	11216	80 × 74	55	84	59,3	16	90	100	74	
11017	11217	100 × 94	60	99,3	64,4	18	105	125	94	125
11018			65		69,4					
11019			75	120	20					