

AIR-OIL HEAT EXCHANGERS

HY -200 Series with Hydraulic Motor , Fixed Thermostat

HY235

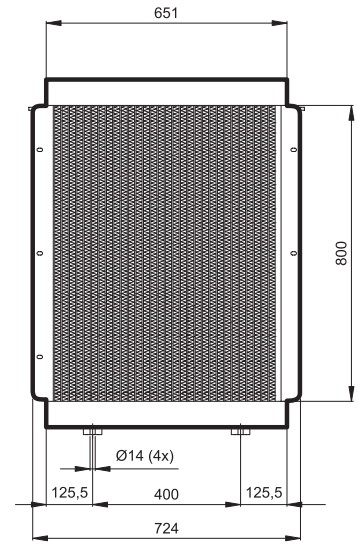
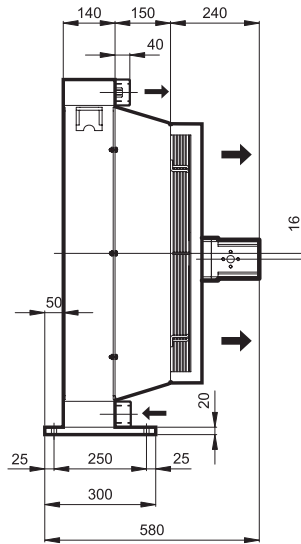
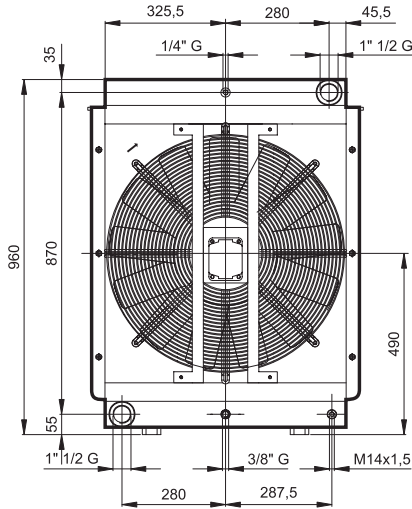

Technical information

Type	Oil flow	Capacity	Weight	Displacement	rpm	Motor flow	Power	Fan Ø	Air flow	Noise Level
	L'	L	Kg	cm ³ /g ³	g/1'	l/1'	W	mm	m ³ /h	dB(A)
HY23505	60 - 300	34	93	17,5	1500	27	1700	630	15000	85
HY23506	60 - 300	34	89	-	-	-	-	630	-	-

