

# AIR-OIL HEAT EXCHANGERS

## HY -200 Series with Hydraulic Motor , Fixed Thermostat

### HY230

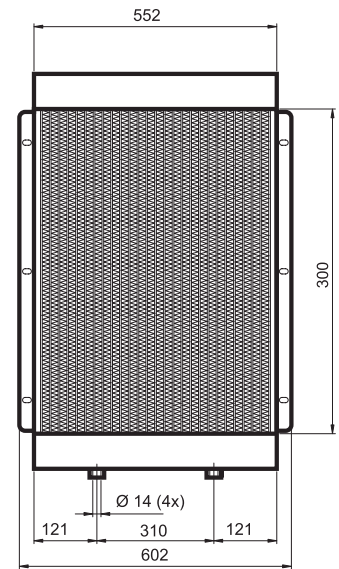
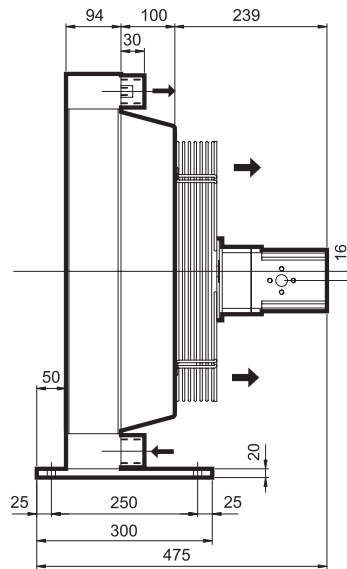
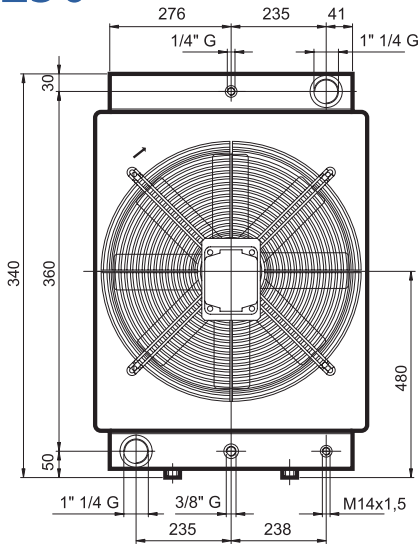

#### Technical information

Type	Oil flow	Capacity	Weight	Displacement	rpm	Motor flow	Power	Fan Ø	Air flow	Noise Level
	L'	L	Kg	cm <sup>3</sup> /g <sup>3</sup>	g/1'	l/1'	W	mm	m <sup>3</sup> /h	dB(A)
HY23005	50 - 200	17	60	17,5	1500	27	1700	560	12000	81
HY23006	50 - 200	17	56	-	-	-	-	560	-	-

