

AIR-OIL HEAT EXCHANGERS

HY -200 Series with Hydraulic Motor , Fixed Thermostat

HY220

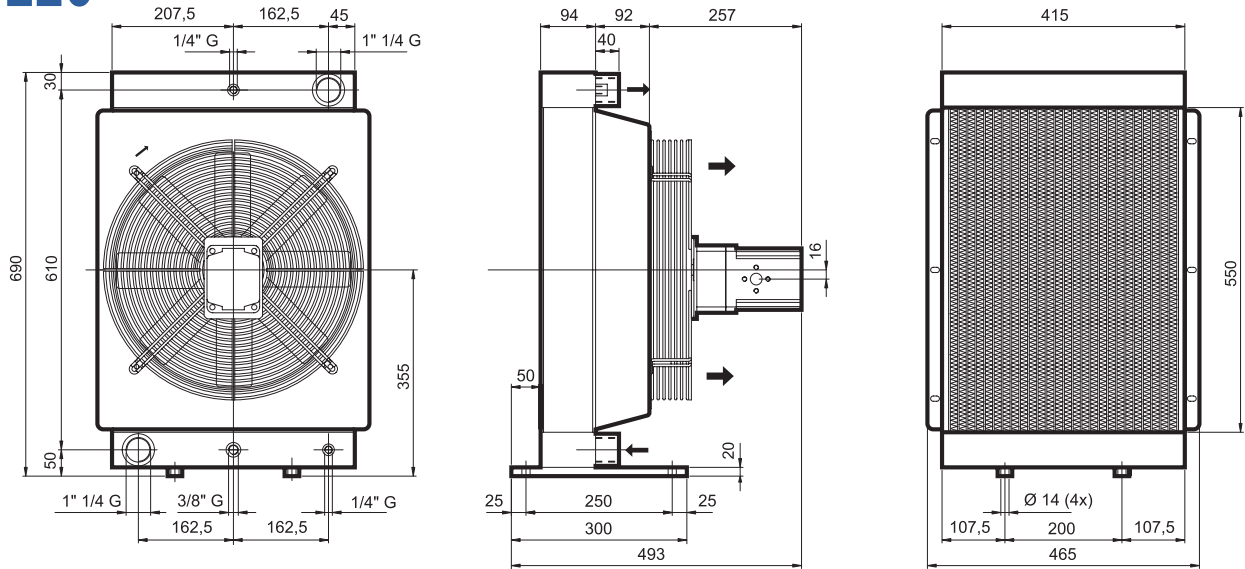

Technical information

Type	Oil flow	Capacity	Weight	Displacement	rpm	Motor flow	Power	Fan Ø	Air flow	Noise Level
	L/1'	L	Kg	cm ³ /g ³	g/1'	l/1'	W	mm	m ³ /h	dB(A)
HY22005	30 - 180	11	39	11	2000	23	850	400	8000	78
HY22006	30 - 180	11	35	-	-	-	-	400	-	-

