

# AIR-OIL HEAT EXCHANGERS

## HY -200 Series with DC motor, Fixed Thermostat

### HY225

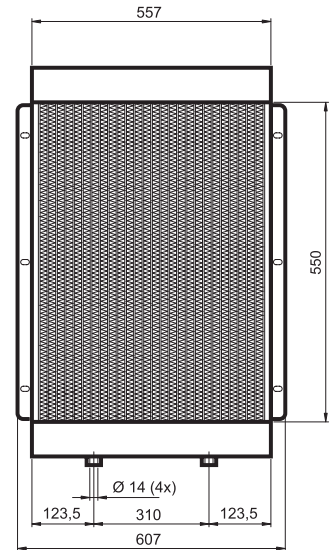
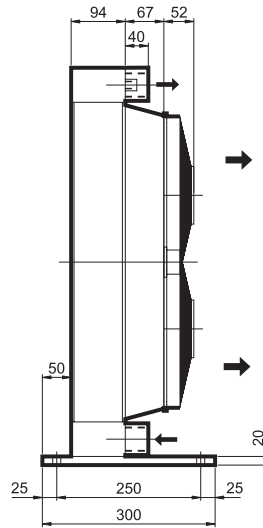
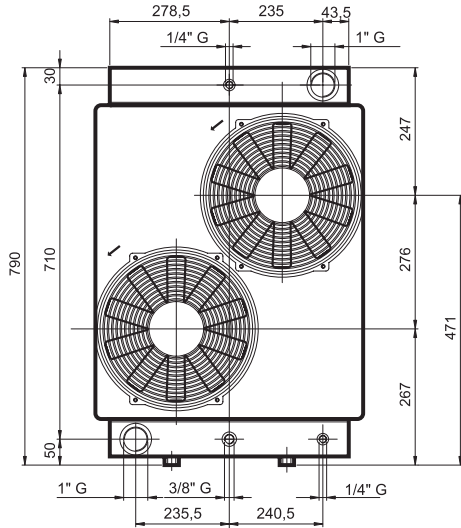

12 Volt
24 Volt

FAN
IP68
UNI-EN 294
60 °C
CE PBD
TEST 35 bar
STATIC 24 bar
DYNAMIC 16 bar

#### Technical information

Type	Oil flow	Capacity	Weight	Voltage	Current	Power	Fan Ø	Air flow	Noise Level
	L'	L	Kg	V	A	W	mm	m <sup>3</sup> /h	dB(A)
HY22502	30 - 180	15	53	12	2 X 17,6	2 X 211	2 X 305	2 X 1830	80
HY22504	30 - 180	15	53	24	2 X 7,6	2 X 182	2 X 305	2 X 1960	80

