

AIR-OIL HEAT EXCHANGERS

HY -200 Series with DC motor, Fixed Thermostat

HY220

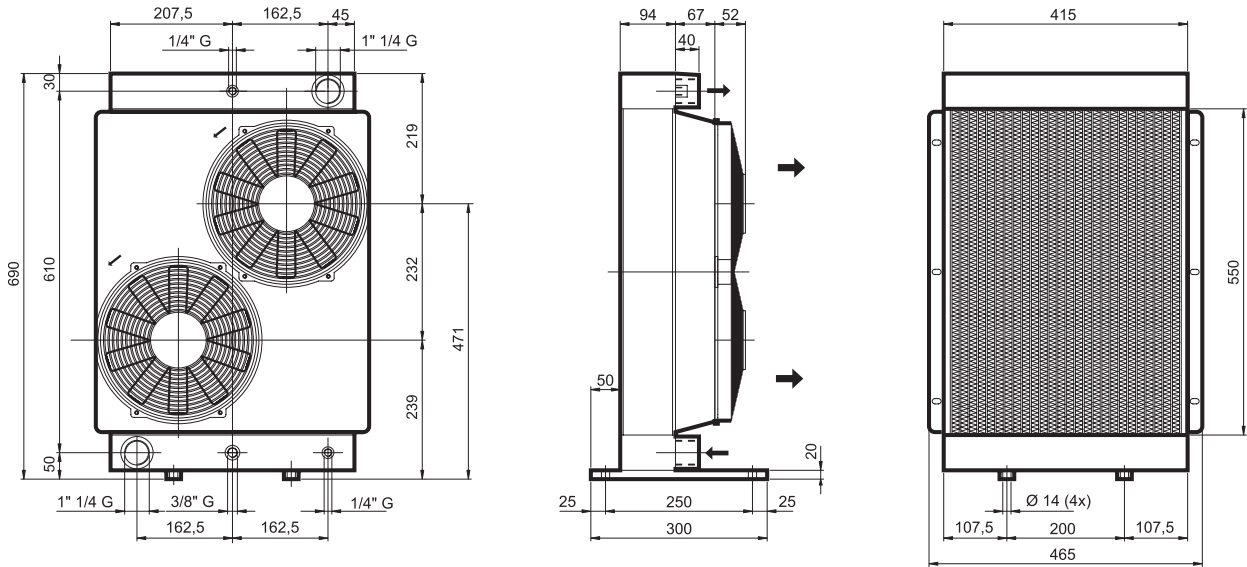

Technical information

Type	Oil flow	Capacity	Weight	Voltage	Current	Power	Fan Ø	Air flow	Noise Level
	L'	L	Kg	V	A	W	mm	m³/h	dB(A)
HY22002	30 - 180	11	33	12	2 X 9,2	2 X 110	2 X 280	2 X 1400	75
HY22004	30 - 180	11	33	24	2 X 4,5	2 X 108	2 X 280	2 X 1400	75

