

# AIR-OIL HEAT EXCHANGERS

## HY -200 Series with DC motor, Fixed Thermostat

### HY215

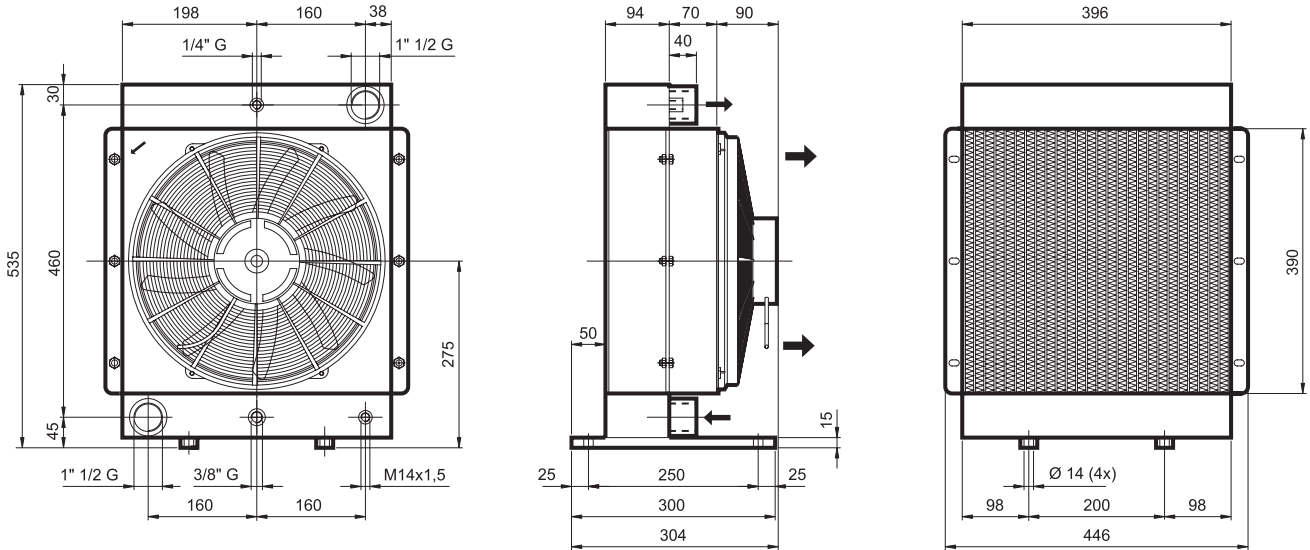

#### Technical information

Type	Oil flow	Capacity	Weight	Voltage	Current	Power	Fan Ø	Air flow	Noise Level
	L'	L	Kg	V	A	W	mm	m³/h	dB(A)
HY21502	30 - 120	8,75	23	12	21	252	385	2390	76
HY21504	30 - 120	8,75	23	24	10	240	385	2390	76

