

AIR-OIL HEAT EXCHANGERS

HY -200 Series with AC motor, Fixed Thermostat

HY230

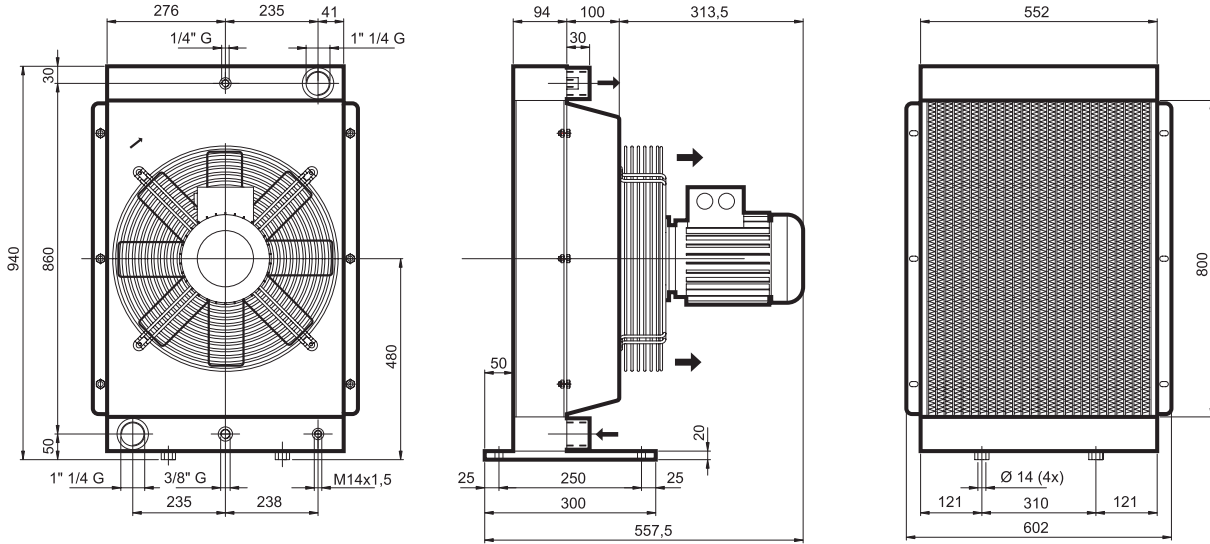

Technical information										
Type	Oil flow	Capacity	Weight	Voltage	Frequency	Current	Power	Fan Ø	Air flow	Noise Level
	L'	L	Kg	V	Hz	A	W	mm	m³/h	dB(A)
HY23003	50-200	18	65	230/400	50	4,8-2,7	1100	560	8000	82
				260/460	60	4,2-2,4				

