

AIR-OIL HEAT EXCHANGERS

HY -200 Series with AC motor, Fixed Thermostat

HY220

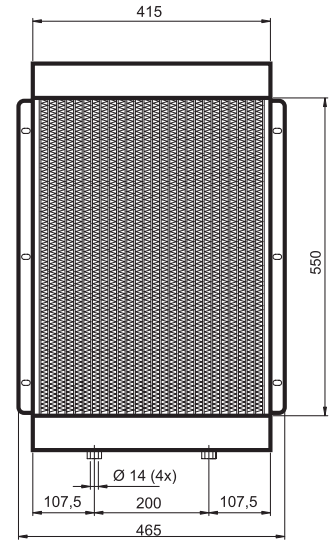
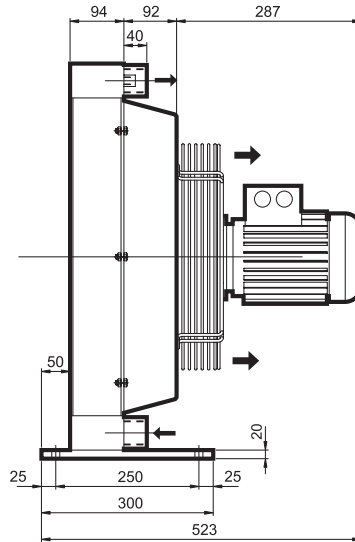
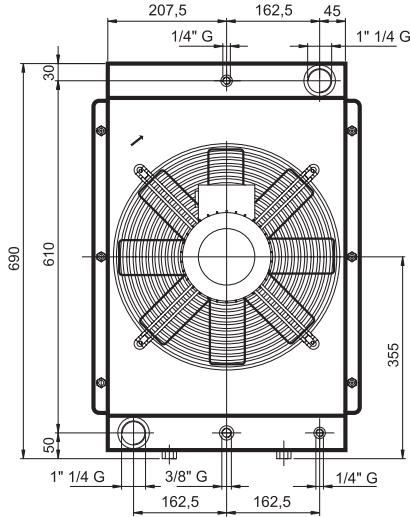

B14
4 poles
230
400
Volt
260
460
Volt

FAN
IP55
UNI-EN 294
60 °C
CE
PBD
TEST 35
bar
STATIC 24
bar
DYNAMIC 16
bar

Technical information										
Type	Oil flow	Capacity	Weight	Voltage	Frequency	Current	Power	Fan Ø	Air flow	Noise Level
	L'	L	Kg	V	Hz	A	W	mm	m ³ /h	dB(A)
HY22003	30-180	11	38	230/400	50	3,2-1,8	750	450	3800	80
				260/460	60	2,8-1,6				

