

AIR-OIL HEAT EXCHANGERS

HY -200 Series with AC motor, Fixed Thermostat

HY215

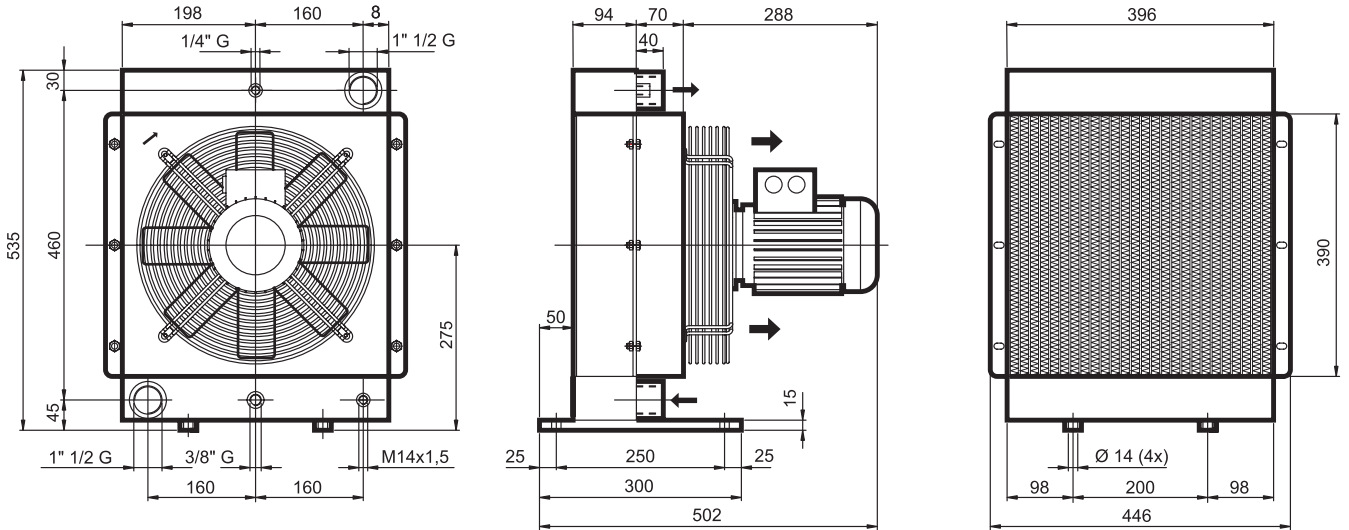

Technical information										
Type	Oil flow	Capacity	Weight	Voltage	Frequency	Current	Power	Fan Ø	Air flow	Noise Level
	L'	L	Kg	V	Hz	A	W	mm	m³/h	dB(A)
HY21503	30-120	8,7	28	230/400	50	2,4/1,4	0,55	400	3500	80
				260/460	60	2,1/1,2				

