

AIR-OIL HEAT EXCHANGERS

HY-100 Series with DC Motor, Adjustable Thermostat

HY055

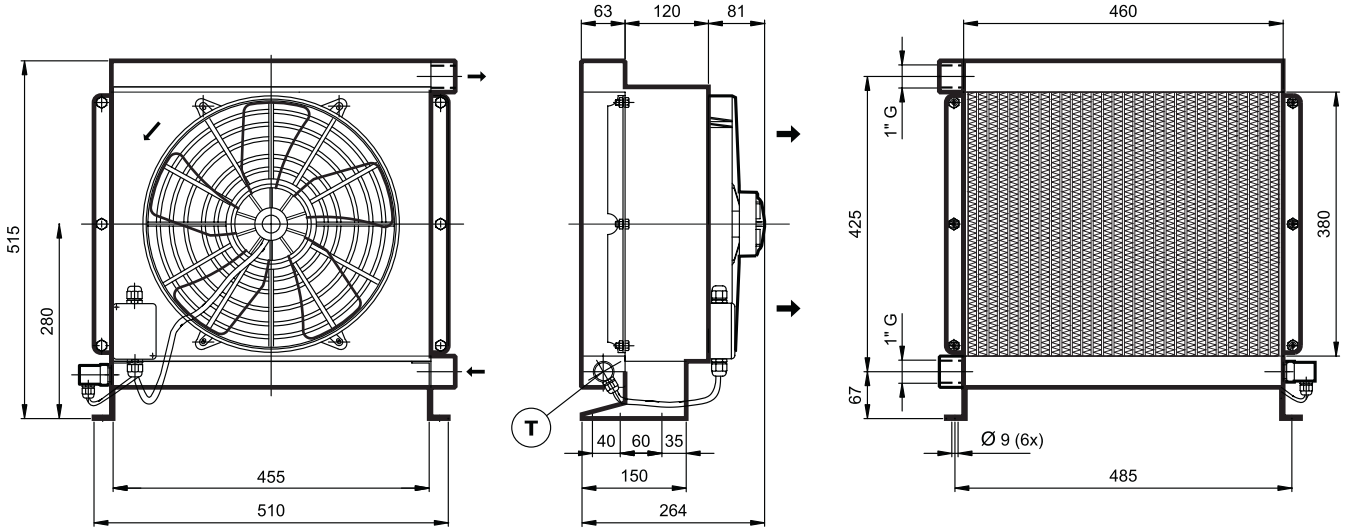

Technical information									
Type	Oil flow	Capacity	Weight	Voltage	Current	Power	Fan \varnothing	Air flow	Noise Level
	L'	L	Kg	V	A	W	mm	m ³ /h	dB(A)
HY05502	50 - 200	6,3	19,5	12	20	246	350	2360	72
HY05504	50 - 200	6,3	19,5	24	10	240	350	2360	72

