

HY037

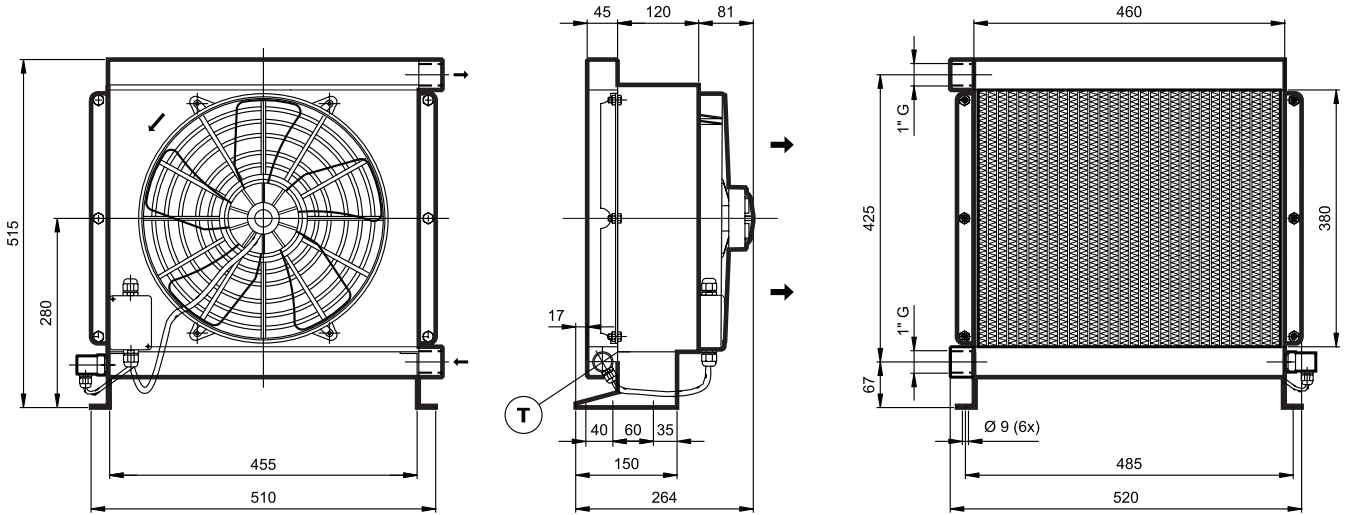

Technical information									
Type	Oil flow	Capacity	Weight	Voltage	Current	Power	Fan Ø	Air flow	Noise Level
	L'	L	Kg	V	A	W	mm	m ³ /h	dB(A)
HY03702	50 - 200	4,2	17,5	12	20	246	350	2360	72
HY03704	50 - 200	4,2	17,5	24	10	240	350	2360	72

