

HY020

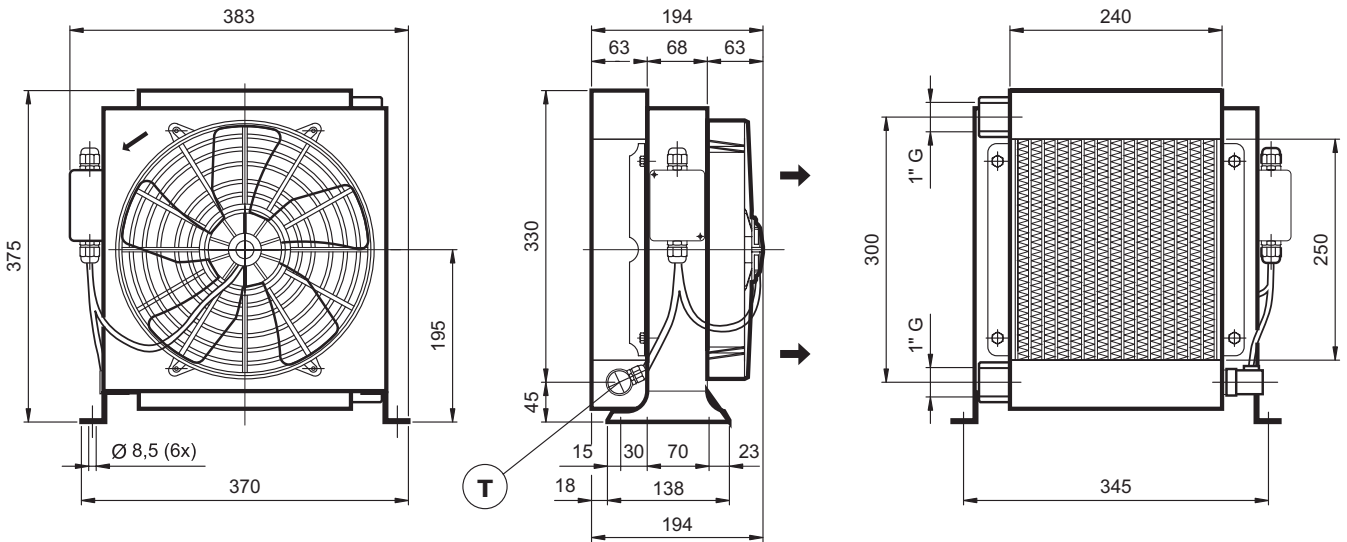

Technical information

Type	Oil flow	Capacity	Weight	Voltage	Current	Power	Fan Ø	Air flow	Noise Level
	L'	L	Kg	V	A	W	mm	m ³ /h	dB(A)
HY02002	30 - 120	2,7	8,5	12	9,2	110	280	1210	70
HY02004	30 - 120	2,7	8,5	24	4,5	108	280	1210	70

