

AIR-OIL HEAT EXCHANGERS

HY-100 Series with DC Motor, Fixed Thermostat

HY018

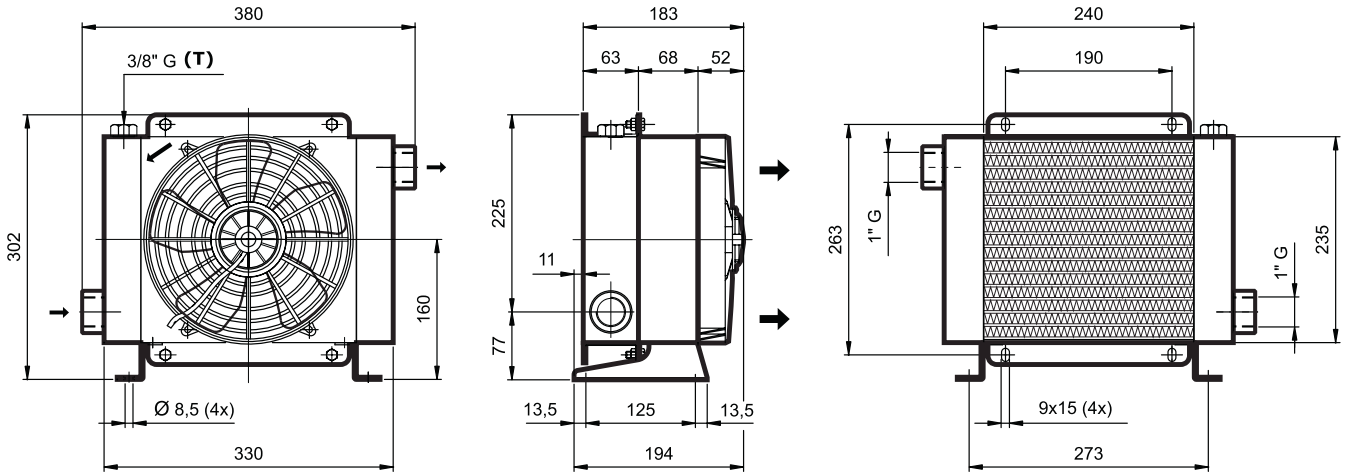

Technical information

| Type | Oil flow | Capacity | Weight | Voltage | Current | Power | Fan Ø | Air flow | Noise Level |
|---------|----------|----------|--------|---------|---------|-------|-------|-------------------|-------------|
| | L' | L | Kg | V | A | W | mm | m ³ /h | dB(A) |
| HY01802 | 20 - 100 | 2,3 | 7 | 12 | 7,6 | 91,2 | 225 | 620 | 70 |
| HY01804 | 20 - 100 | 2,3 | 7 | 24 | 4 | 96 | 225 | 800 | 70 |

