

AIR-OIL HEAT EXCHANGERS

HY-100 Series with DC Motor, Fixed Thermostat

HY016

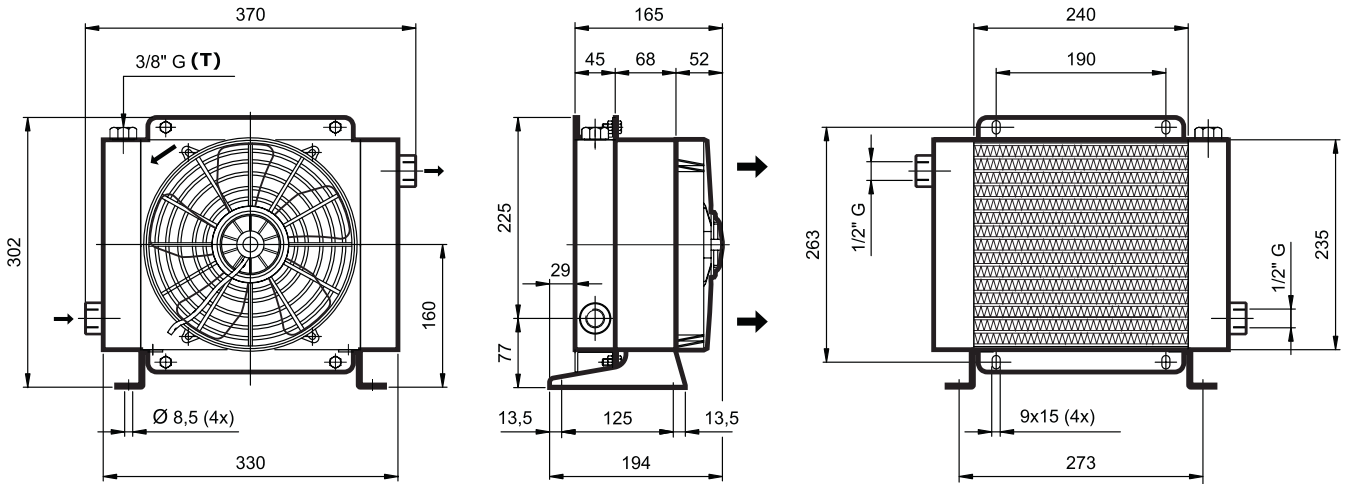

Technical information									
Type	Oil flow	Capacity	Weight	Voltage	Current	Power	Fan Ø	Air flow	Noise Level
	L'	L	Kg	V	A	W	mm	m ³ /h	dB(A)
HY01602	20 - 80	1,6	6	12	7,6	91,2	225	650	68
HY01604	20 - 80	1,6	6	24	4	96	225	830	68

