

# AIR-OIL HEAT EXCHANGERS

## HY-100 Series with DC Motor, Fixed Thermostat

### HY014

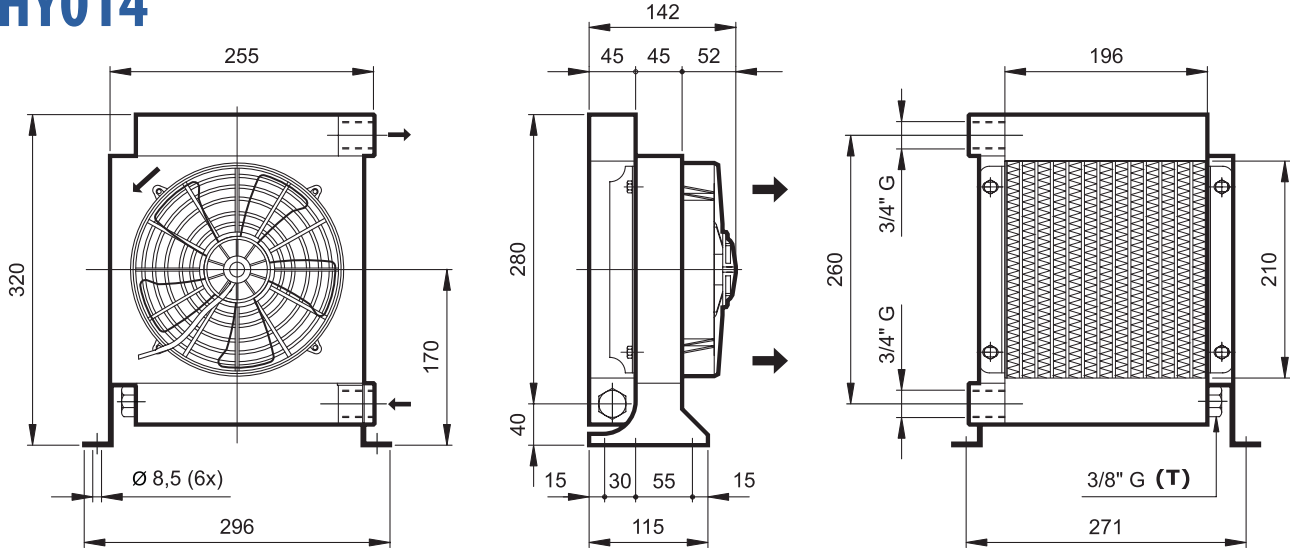

#### Technical information

Type	Oil flow	Capacity	Weight	Voltage	Current	Power	Fan Ø	Air flow	Noise Level
	L'	L	Kg	V	A	W	mm	m³/h	dB(A)
HY01402	10 - 50	1,3	4,7	12	8,2	98,4	190	670	70
HY01404	10 - 50	1,3	4,7	24	2,6	62,4	190	520	70

