

HY098

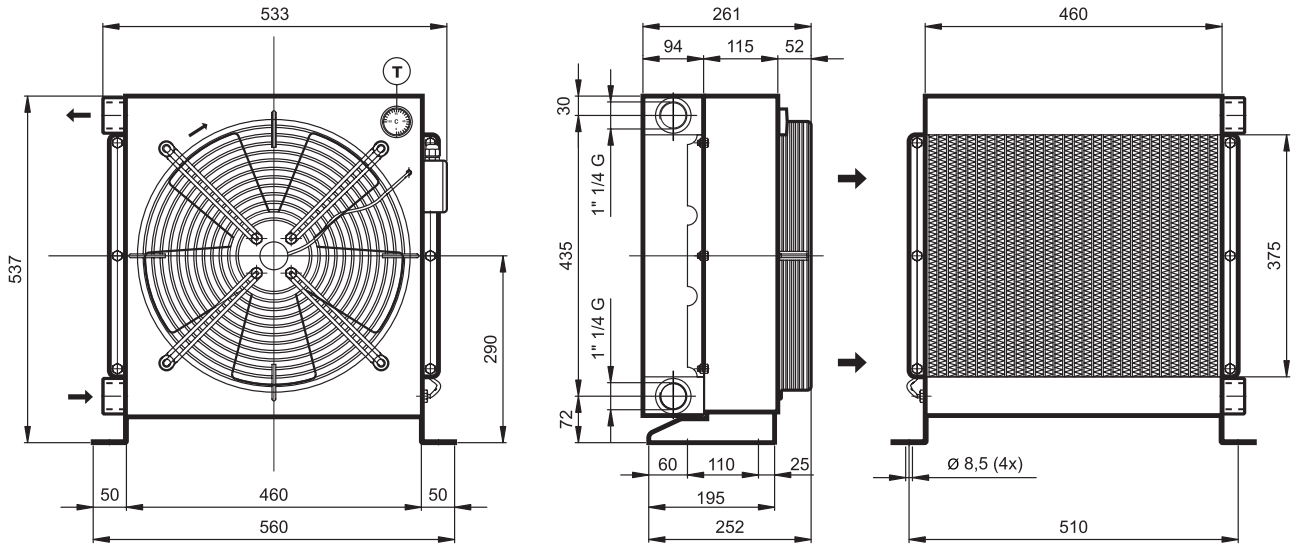

Technical information

Type	Oil flow	Capacity	Weight	Voltage	Frequency	Current	Power	Fan Ø	Air flow	Noise Level
	L/h	L	Kg	V	Hz	A	W	mm	m³/h	dB(A)
HY09803	60 - 240	9,8	28	230/400	50/60	0,56/0,78	130/180	400	2400	70

