

# AIR-OIL HEAT EXCHANGERS

## HY-100 Series with AC motor, Adjustable Thermostat

### HY037

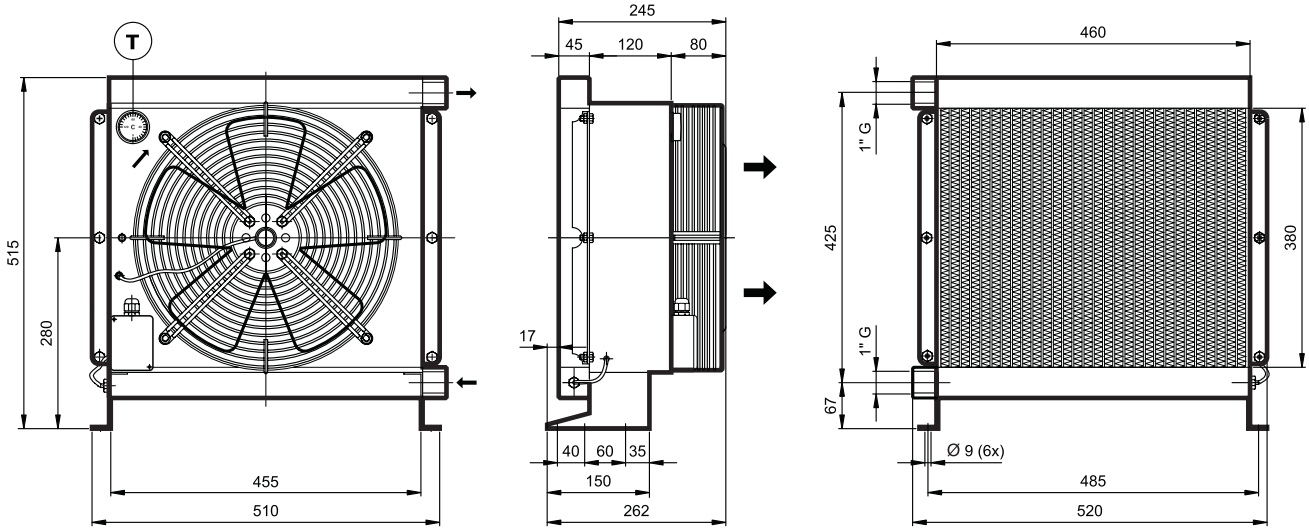

#### Technical information

Type	Oil flow	Capacity	Weight	Voltage	Frequency	Current	Power	Fan Ø	Air flow	Noise Level
	L/h	L	Kg	V	Hz	A	W	mm	m³/h	dB(A)
HY03701	50 - 200	4,2	18,4	230	50/60	0,52/0,74	120/170	350	2700	72
HY03703	50 - 200	4,2	18,4	230/400	50/60	0,56/0,78	130/180	350	2700	72

