

### HY018

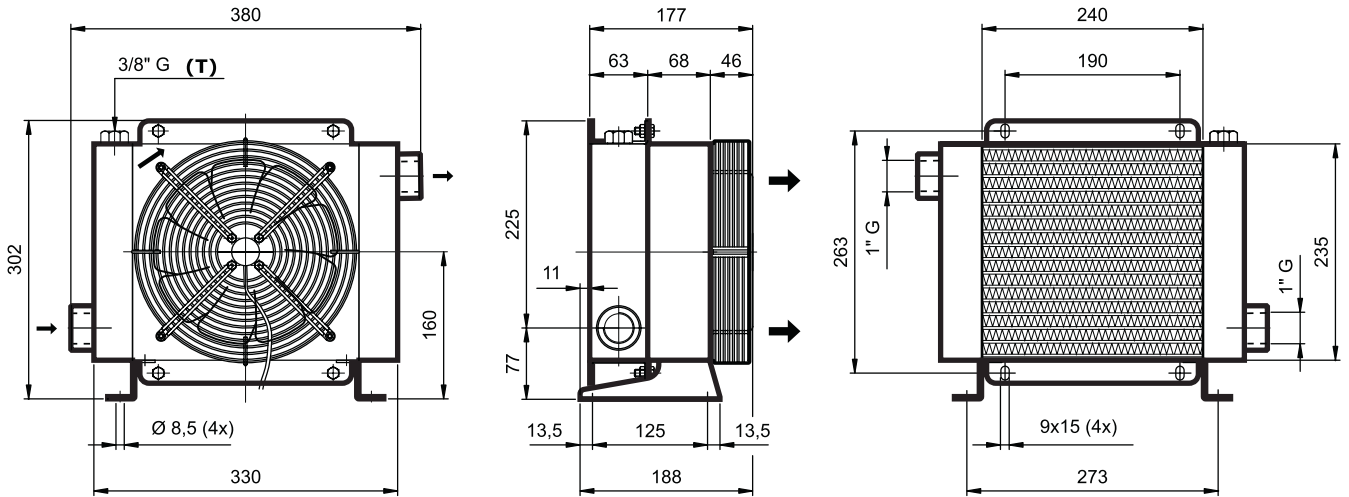

Technical information										
Type	Oil flow	Capacity	Weight	Voltage	Frequency	Current	Power	Fan Ø	Air flow	Noise Level
	L'	L	Kg	V	Hz	A	W	mm	m³/h	dB(A)
HY01801	20 - 100	2,3	7,7	230	50/60	0,27/0,33	62/76	200	650	67
HY01803	20 - 100	2,3	7,7	230/400	50/60	1,28/1,1	66/68	200	650	67

