

AIR-OIL HEAT EXCHANGERS

HY-100 Series with AC motor, Fixed Thermostat

HY005

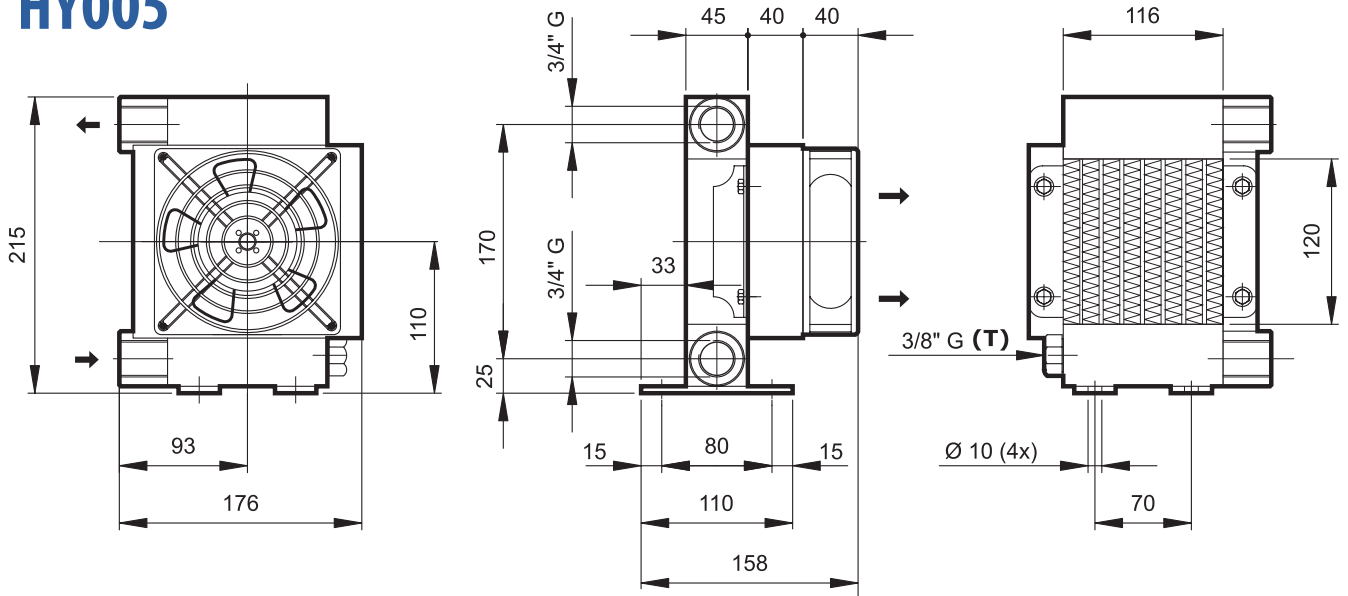

Technical information

Type	Oil flow	Capacity	Weight	Voltage	Frequency	Current	Power	Fan Ø	Air flow	Noise Level
	L'	L	Kg	V	Hz	A	W	mm	m ³ /h	dB(A)
HY00501	5 - 25	0,6	5	230	50/60	0,13/0,11	30/26	120	150	46

