

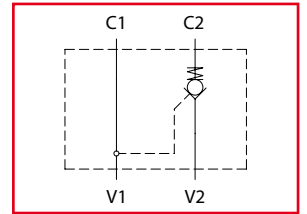

VRSE

Valvole di blocco a semplice effetto
Single acting pilot check valves



Dati tecnici Technical data	
Viscosità fluido Fluid viscosity	10-500 mm ² /s 45 to 2000 ssu (6 to 420 cSt)
Classe di contaminazione Filtration	ISO code 16/13 SAE class 4 or better
Temperatura fluido Fluid temperature	-20°C +80°C -4°F +176°F
Temperatura ambiente Ambient temperature	-20°C +50°C -4°F +122°F

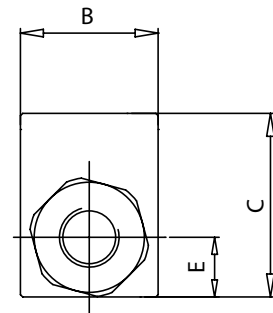
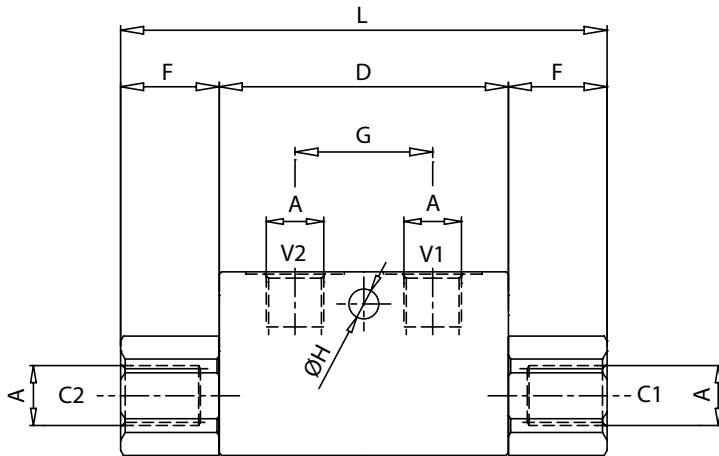
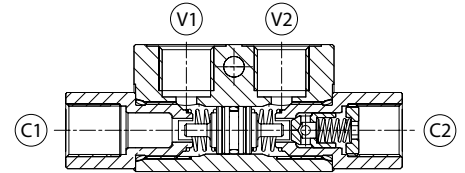

[mm
(Inches)]

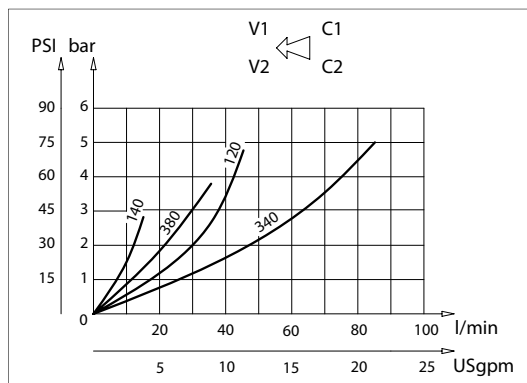
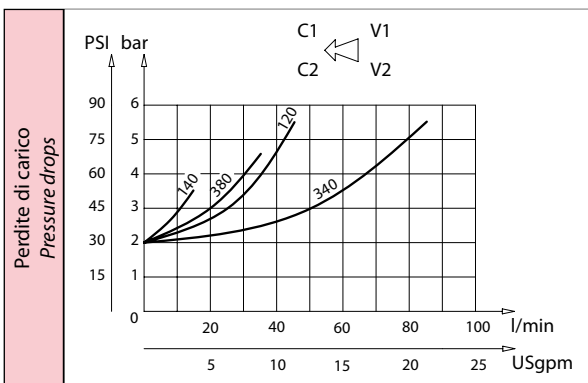

Codice ordinazione Ordering code	
VRSE - X	
X	Dimensione / Size
140	BSPP 1/4
380	BSPP 3/8
120	BSPP 1/2
340	BSPP 3/4

Caratteristiche tecniche Technical performances

Code Codice	A	Portata Max Max flow l/min - USgpm	Pressione Max Max pressure bar/PSI	B	C	D	E	F	G	H	L	Peso approssimativo Approx weight Kg / lb	Rapporto di pilotaggio Pilot ratio
VRSE140	BSPP 1/4	15 (4)	320 (4500)	30 (1.18)	40 (1.57)	63 (2.48)	13 (0.51)	21,5 (0.85)	30 (1.18)	6,5 (0.26)	106 (4.17)	0,63 (1.4)	1:4
VRSE380	BSPP 3/8	35 (9.3)										0,60 (1.32)	
VRSE120	BSPP 1/2	45 (12)	300 (4350)	35 (1.38)	50 (1.97)	82 (3.23)	16,5 (0.65)	31,5 (1.24)	36 (1.42)	8,5 (0.34)	145 (5.71)	1,10 (2.42)	
VRSE340	BSPP 3/4	70 (18.5)										40 (1.57)	



VRSD

Valvole di blocco a semplice effetto DIN2353
Din2353 single acting pilot check valves

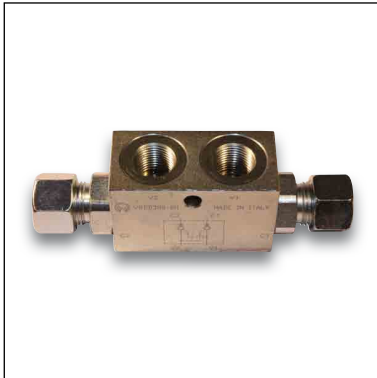
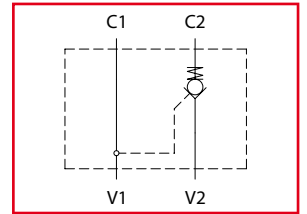

Dati tecnici Technical data	
Viscosità fluido Fluid viscosity	10-500 mm ² /s 45 to 2000 ssu (6 to 420 cSt)
Classe di contaminazione Filtration	ISO code 16/13 SAE class 4 or better
Temperatura fluido Fluid temperature	-20°C +80°C -4°F + 176°F
Temperatura ambiente Ambient temperature	-20°C +50°C -4°F + 122°F

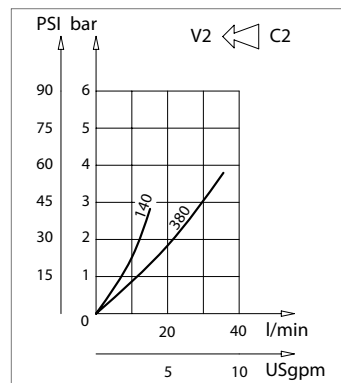
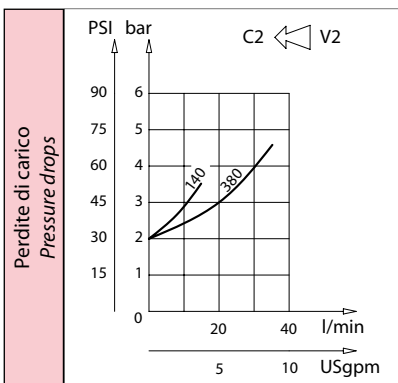
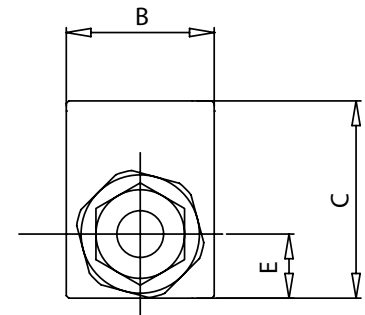
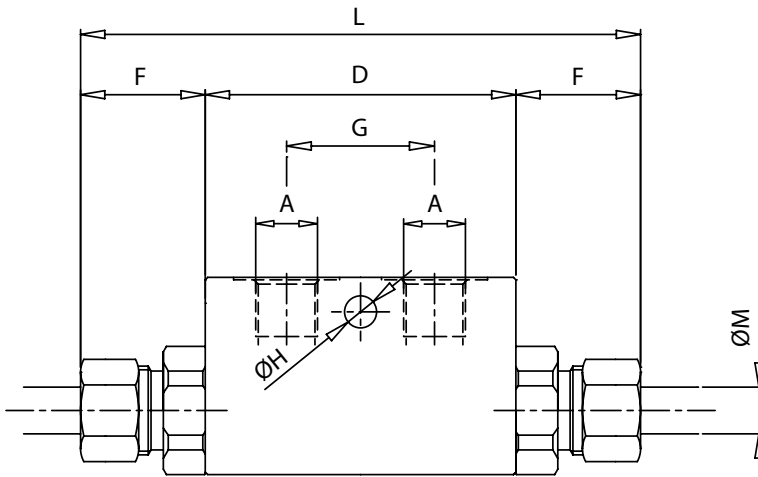
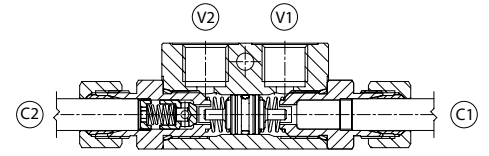

[mm
(Inches)

Codice ordinazione Ordering code			
VRSD - X - Y			
X	Dimensione / Size	Y	Dimensione / Size
140	BSPP 1/4	T8	Per tubo Ø 8 For Ø 8 pipe
380	BSPP 3/8	T12	Per tubo Ø 12 For Ø 12 pipe

Caratteristiche tecniche Technical performances

Code Code	A	Portata Max Max flow l/min - USgpm	Pressione Max Max pressure bar/PSI	B	C	D	E	F	G	H	L	M	Peso approssimativo Approx weight Kg / lb	Rapporto di pilotaggio Pilot ratio
VRSD140T8	BSPP 1/4	10 (2.5)	320 (4500)	30 (1.18)	40 (1.57)	63 (2.48)	13 (0.51)	25 (0.98)	30 (1.18)	6,5 (0.26)	113 (4.45)	8 (0.32)	0,62 (1.4)	1:9
VRSD140T12	BSPP 3/8	15 (4)						32 (1.26)			127 (5)	12 (0.47)		1:4
VRSD380T12	BSPP 1/2	35 (9)												