ITALGROUP - ADVANCED - MOTORS

IAM SERIES

H7 MODEL

***IAM 3900-4300-4600-
5000-5400 H7***

***IAM 3900-4300-4600-
5000-5400/C H7***

INDEX

TECHNICAL DATA - - - - -	<i>Pag.</i>	96
IAM H7 3900-4300-4600-5000-5400 - - - - -	"	97
IAM H7 3900-4300-4600-5000-5400/C - - - - -	"	98
ORDERING INSTRUCTIONS - - - - -	"	99
GRAPHIC PERFORMANCES H7 3900-4300-4600-5000 - - - - -	"	100
GRAPHIC PERFORMANCES H7 5400 - - - - -	"	101

TECHNICAL DATA

H7

	MODEL	IAM 3900 H7	IAM 4300 H7	IAM 4600 H7	IAM 5000 H7	IAM 5400 H7
Displacement	cc/rev	3907	4343	4616	5088	5384
Specific Torque	Nm/bar	62.2	69.1	73.5	81.0	85.7
Max cont. Pressure	bar	250	250	250	250	250
Max int. Pressure	bar	300	300	300	300	300
Peak pressure	bar	350	350	350	350	350
Max continuous speed	rpm	160	150	140	140	130
Peak speed	rpm	200	190	190	180	170
Max continuous power	HP	177	177	177	177	177
	kW	130	130	130	130	130
Max power	HP	241	241	241	241	241
	kW	180	180	180	180	180

- N° of pistons: 7
- Max case pressure: 6 bar
- Max back pressure: 70 bar
- Dry weight: 405 kg
- Temperature range: -30°C ÷ +70°C
- Minimum speed: 0.5 rpm
- Flushing flow: 20 l/min

(*)for further details regarding flushing go to page 10 of this catalogue.

SIZE

IAM 3900-4300-4600-5000-5400 H7

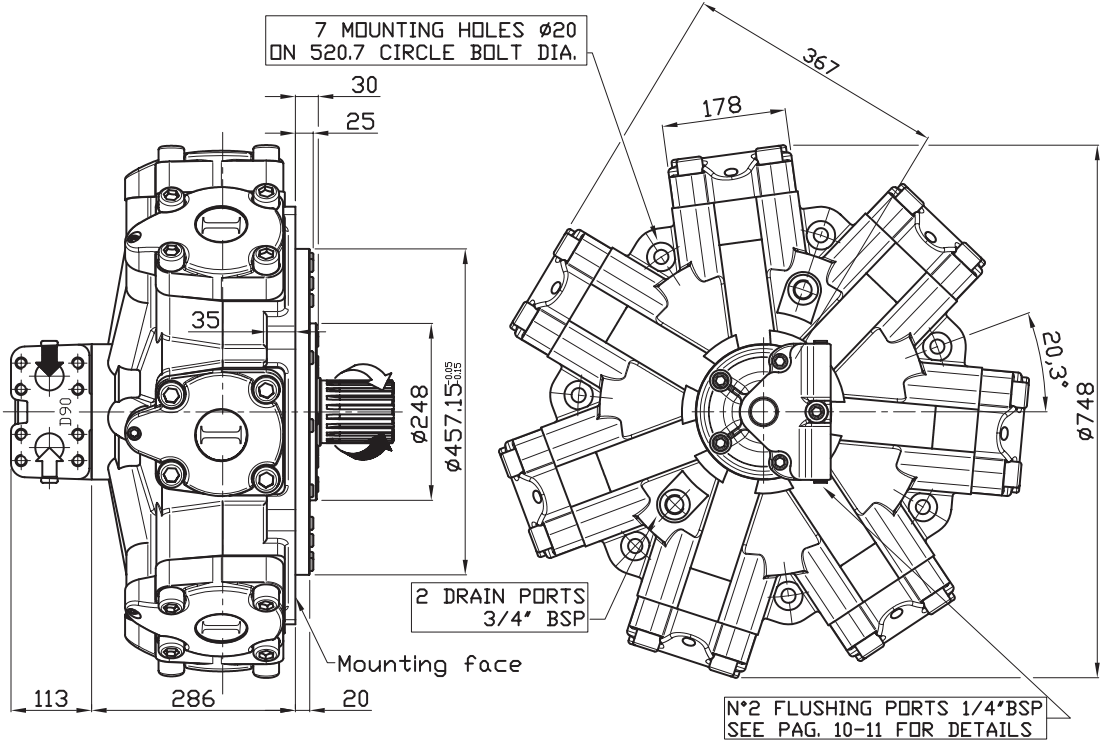

SHAFT

IAM 3900-4300-4600-5000-5400 H7

A1: Standard splined shaft

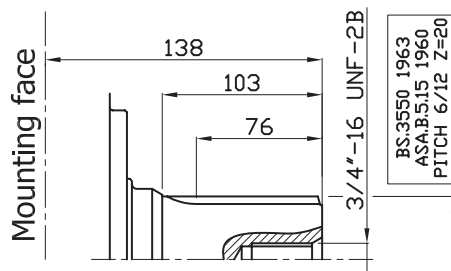

A2: Parallel shaft on request

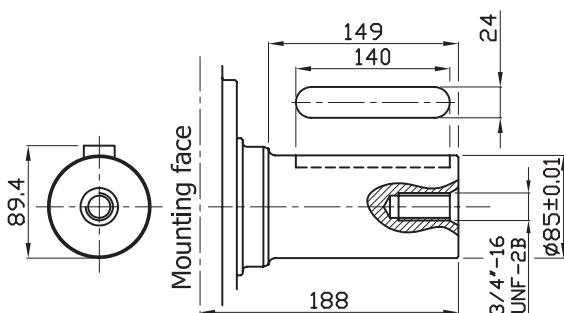

A4: Taper shaft on request

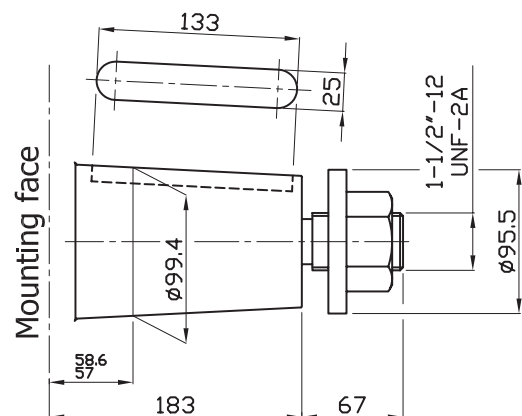

SIZE

IAM 3900/C-4300/C-4600/C-5000/C-5400/C H7

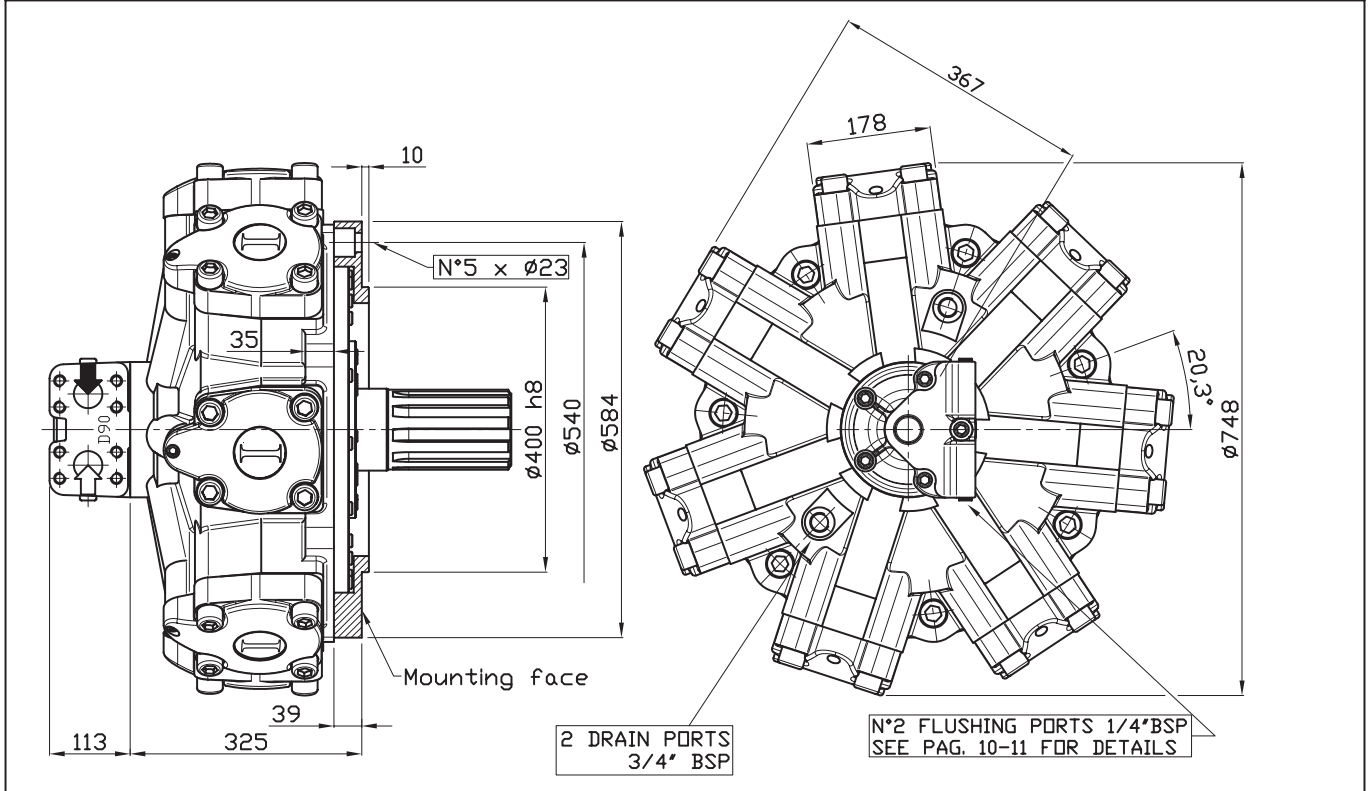

SHAFT

IAM 3900/C-4300/C-4600/C-5000/C-5400/C H7

A0: Standard splined shaft

A2: Parallel shaft on request

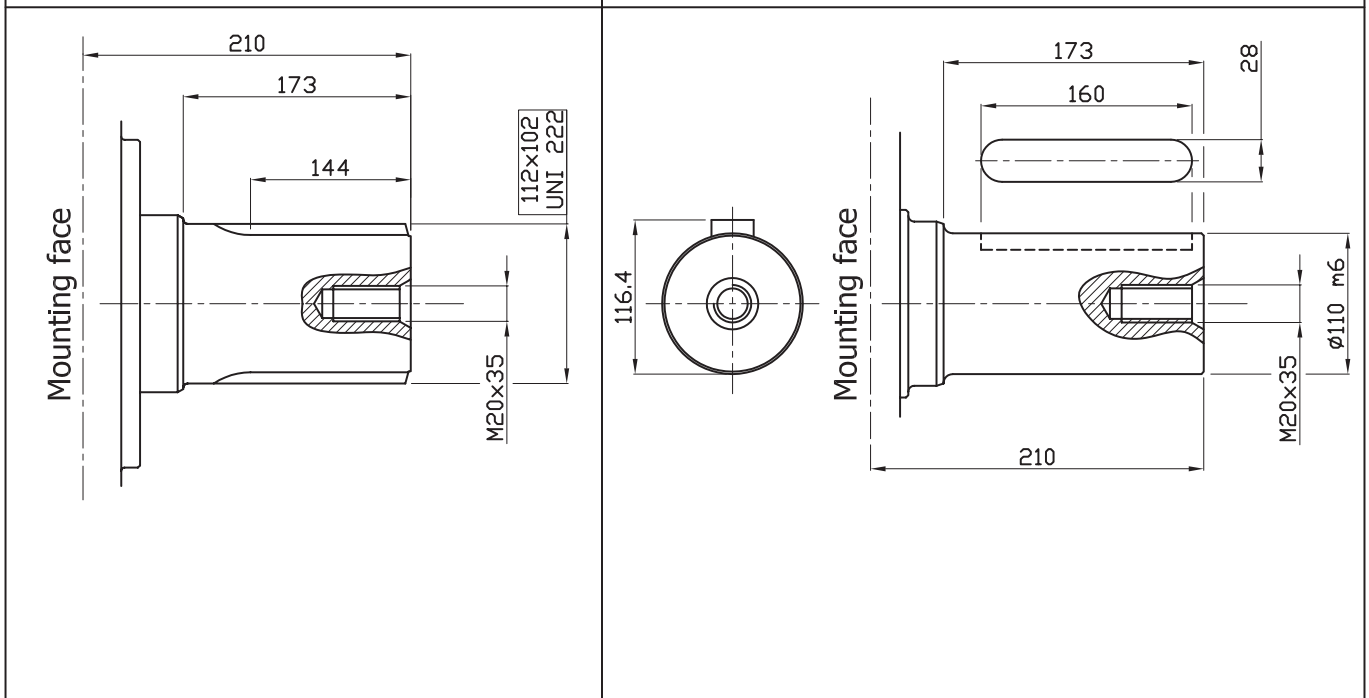

ORDERING INSTRUCTIONS

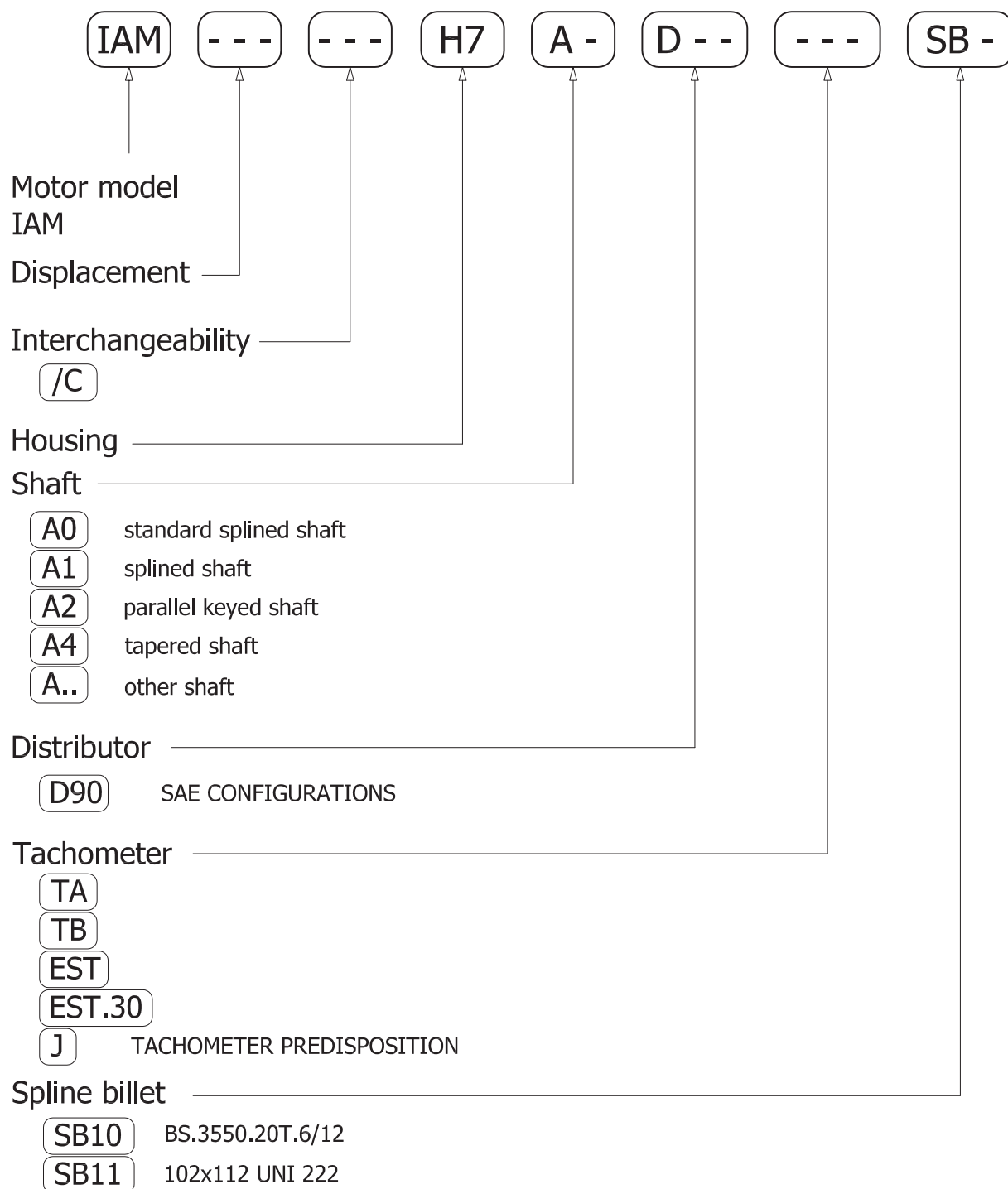

EXAMPLE: IAM.3900.H7.A1.D90
IAM.4600.H7.A1.D90.TA.SB10
IAM.5400/C.H7.A2.D90.J

IAM 3900 H7

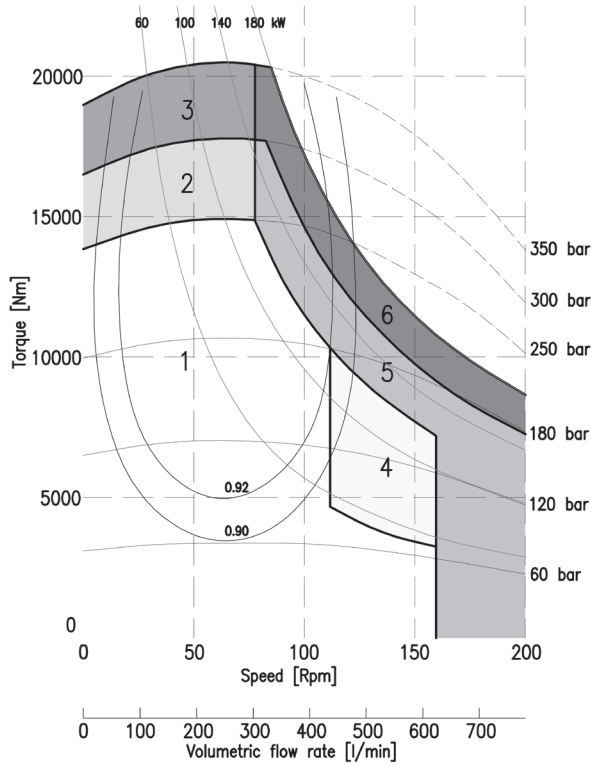

IAM 4300 H7

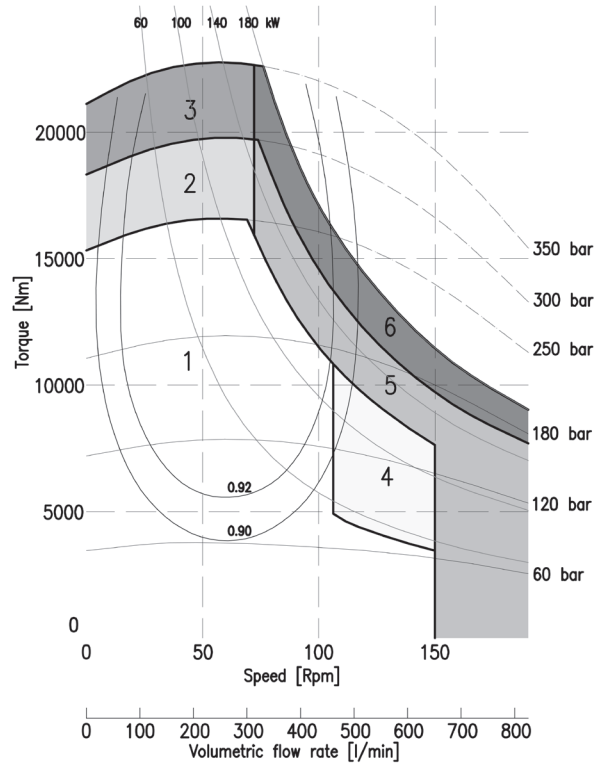

IAM 4600 H7

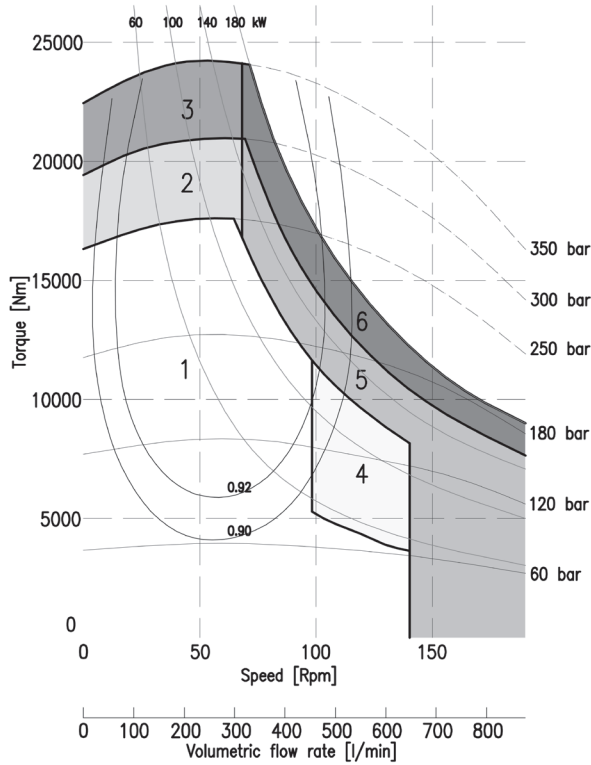

IAM 5000 H7

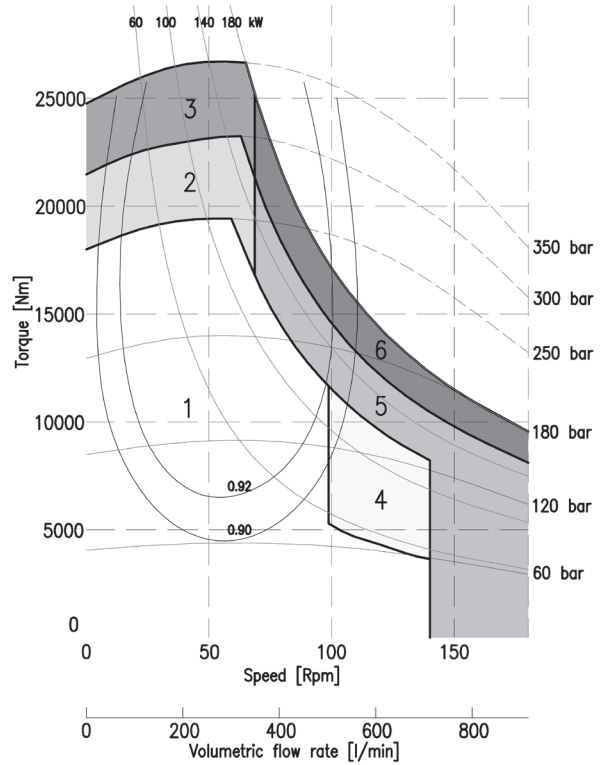

1	Continuous operation
2	Intermittent operation for period 3-5 minutes every 10-15 minutes
3	Intermittent operation for very short period (3-5 seconds every 10-15 minutes)

4	Continuous operation with flushing
5	Intermittent operation for period 3-5 minutes every 10-15 minutes with flushing
6	Intermittent operation for very short period (3-5 seconds every 10-15 minutes) with flushing

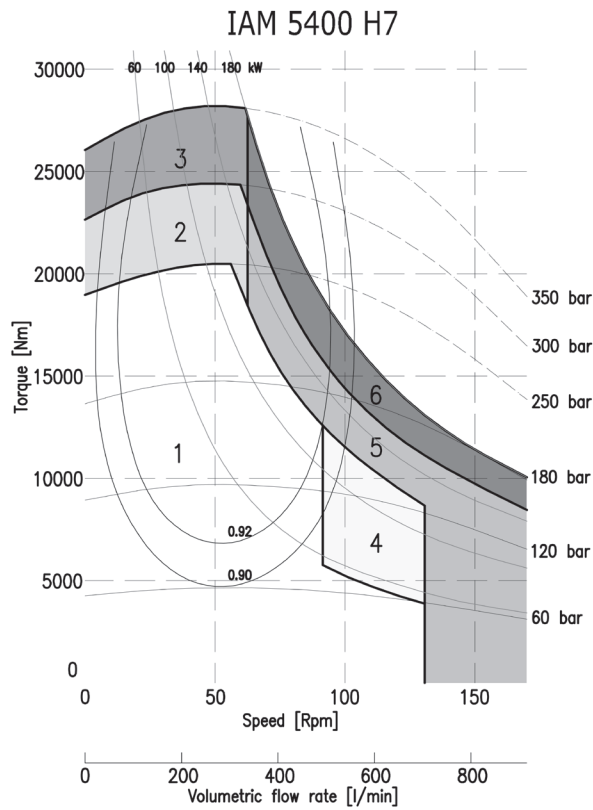

1	Continuous operation
2	Intermittent operation for period 3-5 minutes every 10-15 minutes
3	Intermittent operation for very short period (3-5 seconds every 10-15 minutes)

4	Continuous operation with flushing
5	Intermittent operation for period 3-5 minutes every 10-15 minutes with flushing
6	Intermittent operation for very short period (3-5 seconds every 10-15 minutes) with flushing