

In line high pressure filters

HF 725 series



THE IMPORTANCE OF AN EFFICIENT FILTRATION

The main cause of anomalies in hydraulic systems has to be attributed to the presence of contaminants in the fluid. The nature of the contaminant may be: gaseous, namely air mixed with the fluid; fluid, in most cases it is water that has penetrated the fluid; solid, therefore particles of various origins and dimensions.

The customers who operate equipment are always focused on obtaining the best possible performance, lower energy consumptions and greater respect for the environment.

These characteristics can be attained by using top quality components in the hydraulic system for generating and regulating the fluid power, which are however rather sensitive to the presence of contaminants in the fluid. Starting from these requirements, we understand how important and fundamental it is to prevent the presence of air and water from mixing in the fluid tank by using dedicated solutions.

It is also crucial to limit the presence of solid particles in the hydraulic circuit through a suitable filtering system, which is indispensable to maintain the project requirements of the system over time and to keep running costs low.

The correct choice of a filter and its optimum position in the hydraulic system requires the same care and experience needed to choose all the other components.

The use of filters with larger filtering surfaces reduces, at equal flow rates, the superficial contaminant load and therefore the filter's life is extended proportionally.

To maintain the maximum efficiency of the system, the filters must have a clogging indicator showing the differential pressure on the filtering cartridge and to immediately point out when the cartridge needs replacing in order to prevent the by-pass valve from opening.

The following factors should be analysed when choosing the ideal filter:

- The filtration degree required to protect the most sensitive component from contamination
- The points of the circuit in which the filters have to be installed
- The working pressure of the system
- The maximum flow rate and the type of fluid to be filtered
- The duty cycle
- The retention efficiency of the filtering cartridge
- The contaminant accumulation capacity of the filtering cartridge
- The working ambient temperature

Each filter used generates a pressure drop that increases continuously as time goes by. This pressure drop represents an efficiency index of the filter itself.

When the hydraulic system is about to be assembled, all the components must be perfectly clean and the fluid has to be added through a device complete with a filter.

During the test phase, it is advisable to run some work cycles at low pressure in order to create the best possible conditions for all the components.

TECHNICAL CHARACTERISTICS

The filters of the HF 725 series are connected to the pressure line of the circuit and they protect the system's components against contaminant particles.

The high pressure filters HF725 series are characterized by a direct and modular assembly on valve blocks.

- CETOP 3 connections with reference to ISO4401
- Maximum working pressure 5075 psi (350 bar)
- Modular assembly
- Compact design and low weight
- Element collapse pressure rating 3045 psi (210 bar)

MATERIALS

Head	Spheroidal cast iron EN-GJS-400
Bowl	Steel C45
Seals	Buna - Viton
End cap	Zinc plated steel
Inner tube	Zinc plated steel
Filter media	Inorganic micro-fibre glass Stainless steel

FLUID COMPATIBILITY

Conforming to ISO 2943 (Norm ISO 6743/4)

Oil mineral (1)	HH - HL - HM - HR - HV - HG
Water emulsion (1)	HFAE - HFAS
Water glycol (1)	HFC
Syntetic fluid (2)	HS - HFDR - HFDU - HFDS
(1) With Buna seals	
(2) With Viton seals	

FLOW

Flow max.	5.3 US gpm (20 l/min)
-----------	-----------------------

PRESSURE

Working pressure	5075 psi (350 bar)
Testing pressure	6890 psi (475 bar)
Burst pressure	8705 psi (600 bar)
Element collapse pressure rating (conforming to ISO 2941)	3045 psi (210 bar)

OPERATING TEMPERATURE

With Buna seals	-85 ÷ 195 °F (-30 ÷ 90 °C)
With Viton seals	-70 ÷ 230 °F (-20 ÷ 110 °C)

ENDURANCE STRENGTH

1.000.000 cycle
0 ÷ 5075 psi (0 ÷ 350 bar)

DEGREE OF FILTRATION

Multi-pass test conforming to ISO 16889 (regulation in force)
Contaminant ISO MTD - final Δp 87 psi (6 bar)

Code	Degree of filtration	Ratio $\beta_{x(c)}$	Percentage of efficiency
FG003	5 μm	$\beta_{5(c)} \geq 200$	99,5 %
FG006	7 μm	$\beta_{7(c)} \geq 200$	99,5 %
FG010	10 μm	$\beta_{10(c)} \geq 200$	99,5 %
FG025	21 μm	$\beta_{21(c)} \geq 200$	99,5 %

Multi-pass test conforming to ISO 4572 (previous regulation)
Contaminant ACFTD - final Δp 87 psi (6 bar)

Code	Degree of filtration	Ratio β_x	Percentage of efficiency
FG003	3 μm	$\beta_3 \geq 200$	99,5 %
FG006	6 μm	$\beta_6 \geq 200$	99,5 %
FG010	10 μm	$\beta_{10} \geq 200$	99,5 %
FG025	25 μm	$\beta_{25} \geq 200$	99,5 %

INDICATORS (3)

Visual differential indicator
 Visual electrical differential indicator
 Visual electrical differential indicator with thermostat

(3) Characteristics and dimension pag.8

01/02.2009

SIZING – PRESSURE DROP

The total pressure drop of the filter is calculated by summing the pressure drop value in the housing to that in the filtering element.

$$\text{Total } \Delta p = \Delta p \text{ in housing} + \Delta p \text{ in element}$$

In the filters of series HF 725 in normal working conditions, the total Δp must not be more than 29 psi (2 bar). To establish the values of pressure drop involved, the following pages provide some diagrams with curves referred to the use of mineral oils SAE 10 with kinematic viscosity of 120 SSU (30 cSt) and density of 7.29 lb/gal (0,856 kg/dm³).

Example calculation

Filter HF725-10.100-AS-MI025-HC-B00-B-XN-G

Flow rate= 5.3 US gpm (20 l/min)

Kinematic viscosity: 120 SSU (30 cSt)

Oil density : 7.29 lb/gal (0,856 kg/dm³)

Filtering degree: 25 μm

Data obtained from the diagrams:

Δp in housing = 26.0 psi (1,8 bar) (page 3)

Δp in element = 1.5 psi (0,1 bar) (page 5)

Total $\Delta p = 26.0 + 1.5 = 27.5$ psi (1,9 bar) (Δp is lower than maximum value admitted – therefore sizing is correct).

If oil with different kinematic viscosity and different density is used, the values obtained from the diagrams shall be re-calculated considering the following indications:

1) The pressure drop of the housing is proportional with the oil density, therefore for oil with density different to 7.29 lb/gal (0,856 kg/dm³) the value of the Δp in the head-bowl will be:

$$\Delta p \text{ in housing} = \frac{\Delta p \text{ of diagram (psi)} \cdot \text{Oil density (lb/gal)}}{7.29 \text{ (lb/gal)}} \quad [\text{psi}]$$

Or

$$\Delta p \text{ in housing} = \frac{\Delta p \text{ of diagram (bar)} \cdot \text{Oil density (kg/dm}^3\text{)}}{0,856 \text{ (kg/dm}^3\text{)}} \quad [\text{bar}]$$

2) The pressure drop of the element is proportional with the oil density and kinematic viscosity, therefore for oil with density different to 7.29 lb/gal (0,856 kg/dm³) and kinematic viscosity different to 120 SSU (30 cSt) the value of Δp in the element will be:

$$\Delta p \text{ element} = \Delta p \text{ of diagram (psi)} \cdot \frac{\text{Oil density (lb/gal)}}{7.29 \text{ (lb/gal)}} \cdot \frac{\text{Oil viscosity (SSU)}}{120 \text{ (SSU)}} \quad [\text{psi}]$$

Or

$$\Delta p \text{ element} = \Delta p \text{ of diagram (bar)} \cdot \frac{\text{Oil density (kg/dm}^3\text{)}}{0,856 \text{ (kg/dm}^3\text{)}} \cdot \frac{\text{Oil viscosity (cSt)}}{30 \text{ (cSt)}} \quad [\text{bar}]$$

Now you sum the values of the pressure drop of the housing to the value of the pressure drop of the filtering element, always making sure the total Δp does not exceed the pressure limit of 29 psi (2 bar).

PRESSURE DROP CURVE THROUGH THE HOUSING

The curves are obtained in the following conditions:
 Mineral oil type SAE 10
 Kinematic viscosity 120 SSU (30 cSt)
 Density 7.29 lb/gal (0,856 kg/dm³).

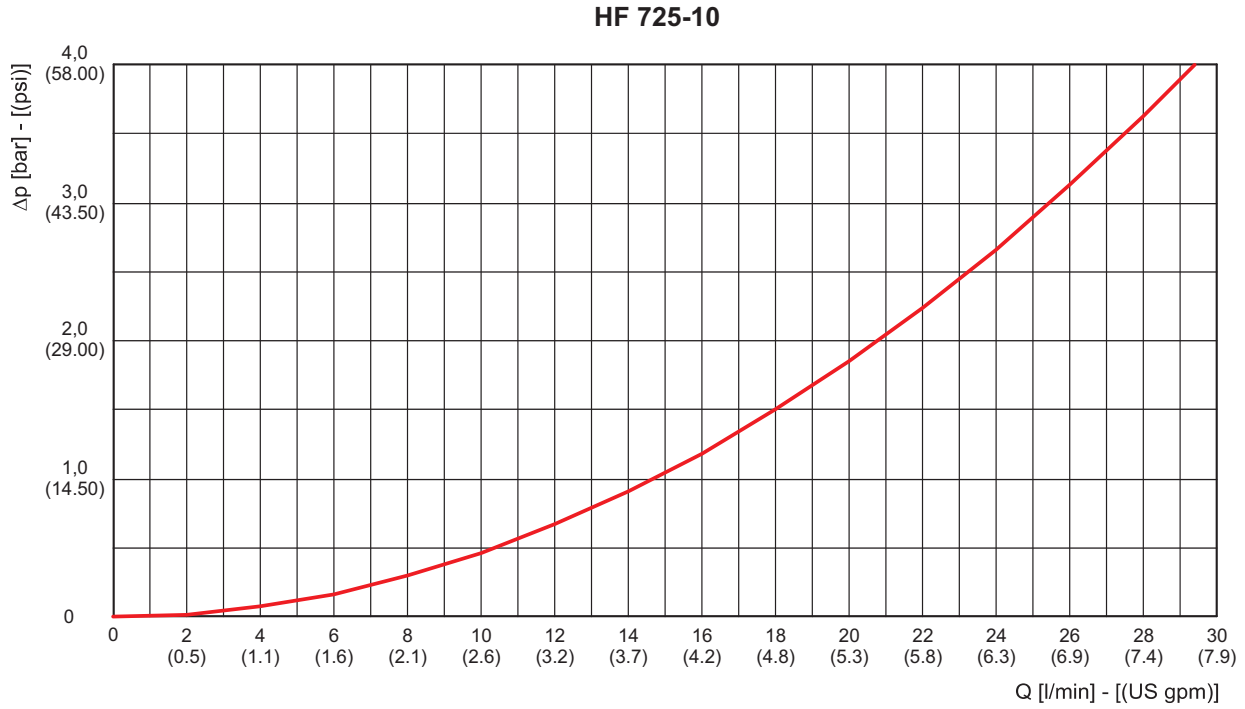

01/02.2009

PRESSURE DROP CURVES THROUGH THE ELEMENT HE K85-10

The curves are obtained in the following conditions:
 Mineral oil type SAE 10
 Kinematic viscosity 120 SSU (30 cSt)
 Density 7.29 lb/gal (0,856 kg/dm³).

FG003

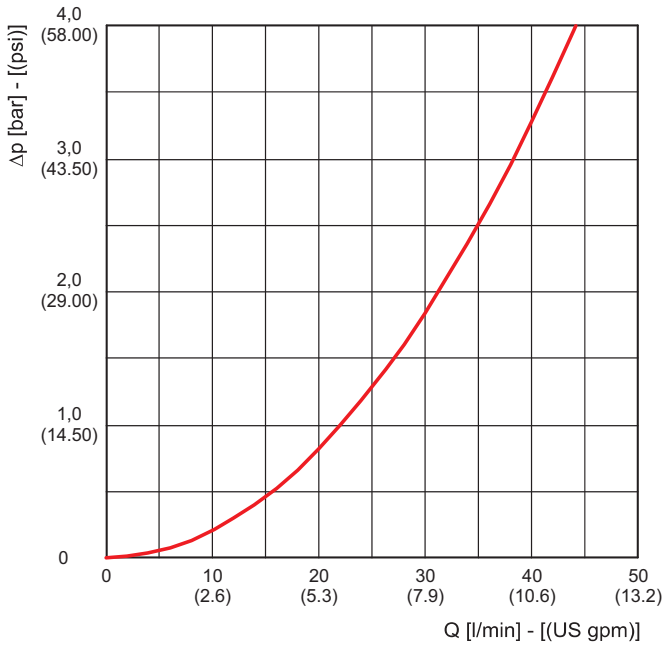

FG006

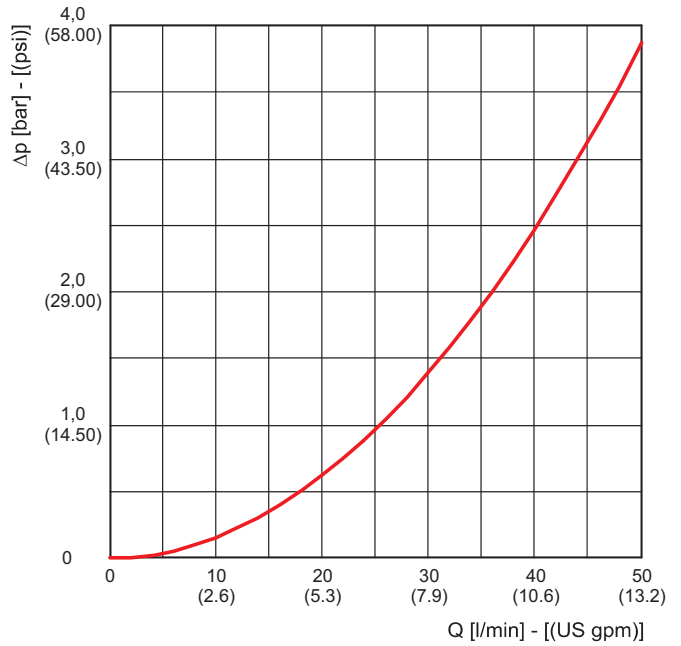

FG010

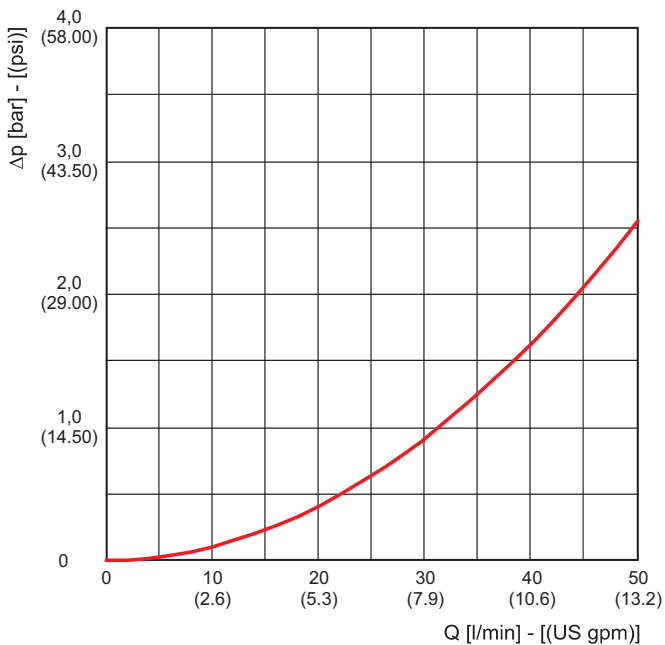

FG025

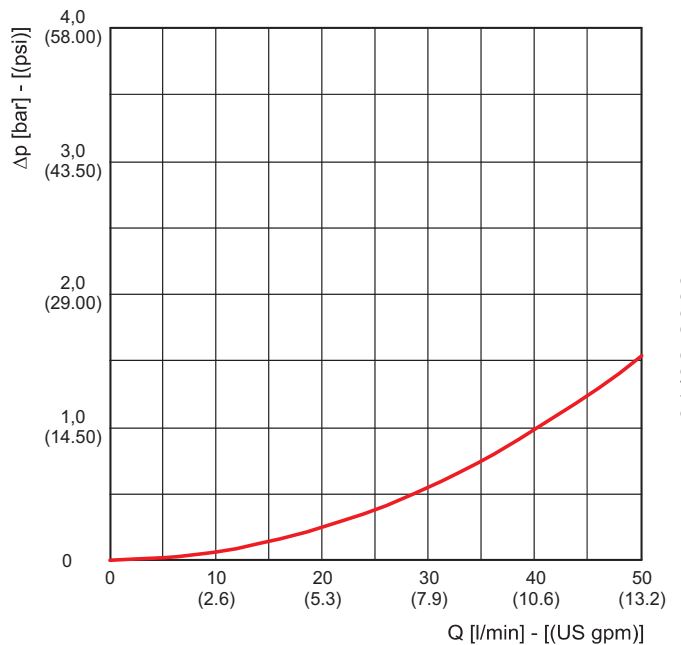

01/02.2009

PRESSURE DROP CURVES THROUGH THE ELEMENT K85-10

The curves are obtained in the following conditions:
 Mineral oil type SAE 10
 Kinematic viscosity 120 SSU (30 cSt)
 Density 7.29 lb/gal (0,856 kg/dm³).

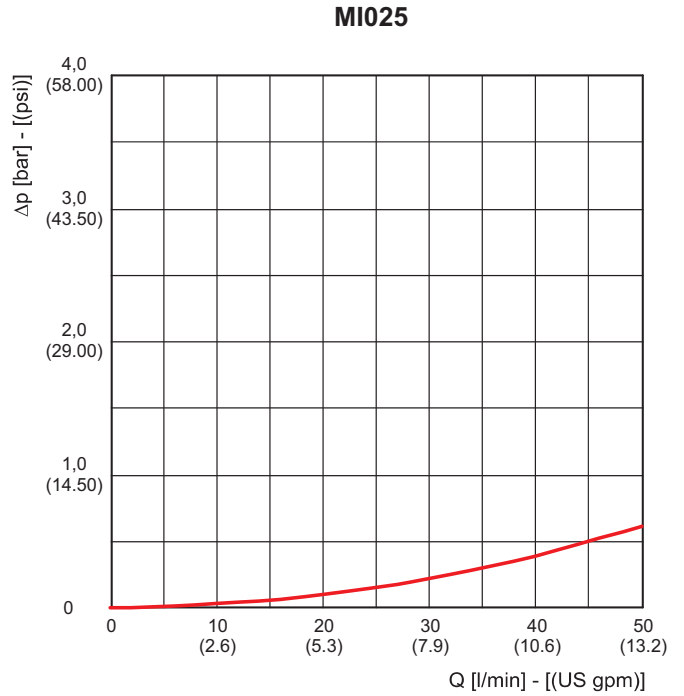
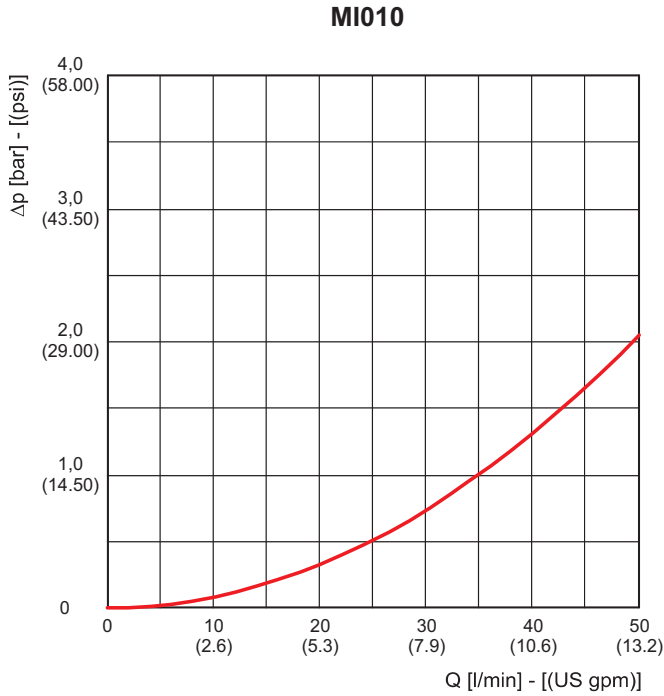

FLOW

Filter type	Degree of filtration					
	FG003	FG006	FG010	FG025	MI010	MI025
	Flow					
	Δp= 29 psi (2 bar)					
	US gpm (l/min)					
HF 725-10.100	4.2 (16)	4.5 (17)	4.8 (18)	5.3 (20)	4.8 (18)	5.3 (20)

01/02.2009

HF 725-10 DIMENSIONS

RIGHT VERSION "A"

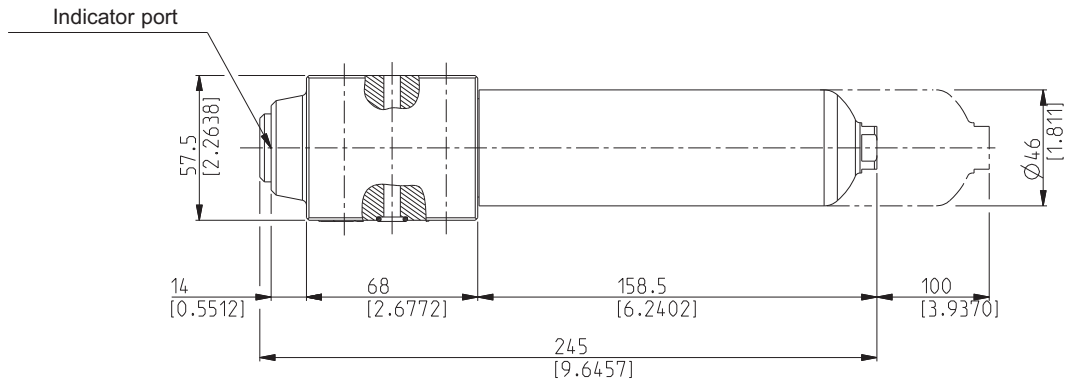
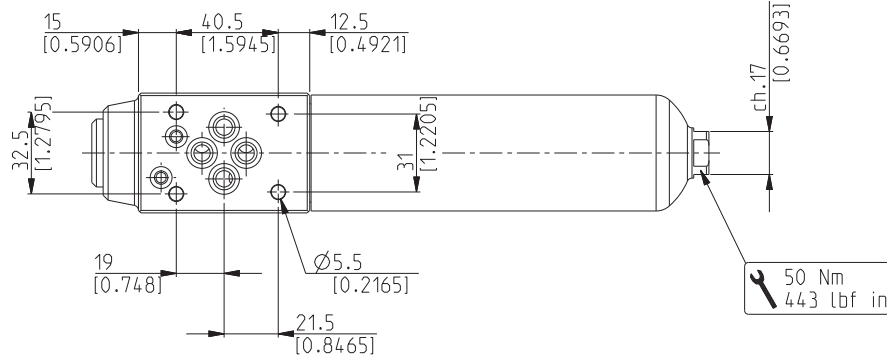

LEFT VERSION "B"

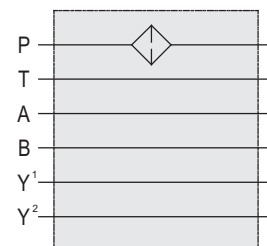
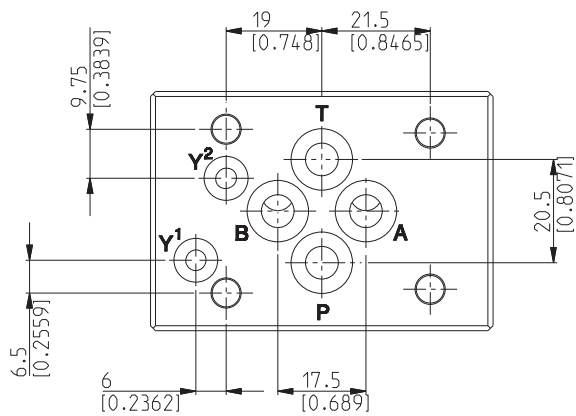
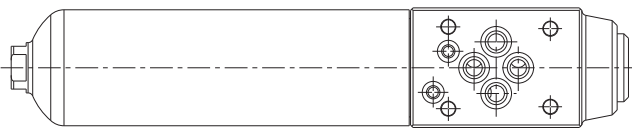

ELEMENTS DIMENSIONS FOR HF 725

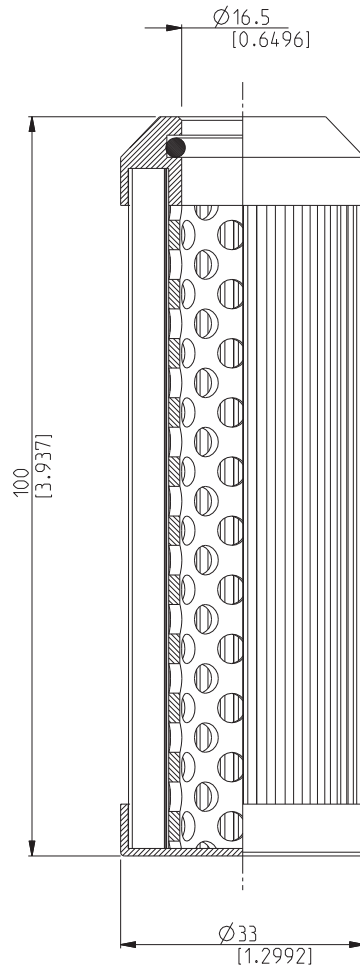

ICAT_023_002_HF725

Δp HE K85-10.100 element's collapse is 3045psi (210 bar).

01/02.2009

Element type	Filtering surface (AS)		Dirt holding capacity (ISO MTD) $\Delta p = 72.5$ psi (5 bar)			
	FG	MI	FG003	FG006	FG010	FG025
	cm ² (in ²)	cm ² (in ²)	gr (lbs)	gr (lbs)	gr (lbs)	gr (lbs)
HE K85-10.100	280 (43.4001)	360 (55.8001)	1,6 (0.0035)	2,0 (0.0044)	2,2 (0.0048)	3,3 (0.0073)

INDICATORS

VISUAL DIFFERENTIAL

Code: **H**

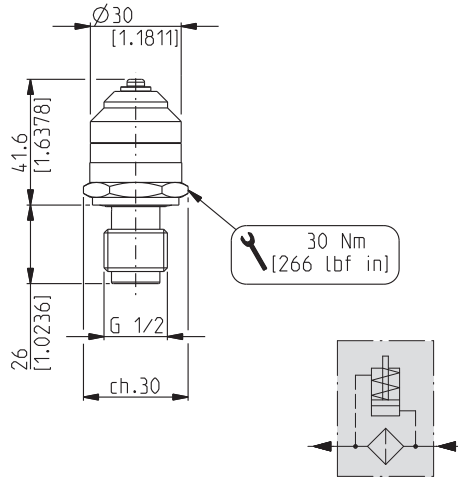

ICAT_011_006_HF760

Differential pressure setting 116 psi (8 bar)

VISUAL ELECTRICAL DIFFERENTIAL

Code: **U**

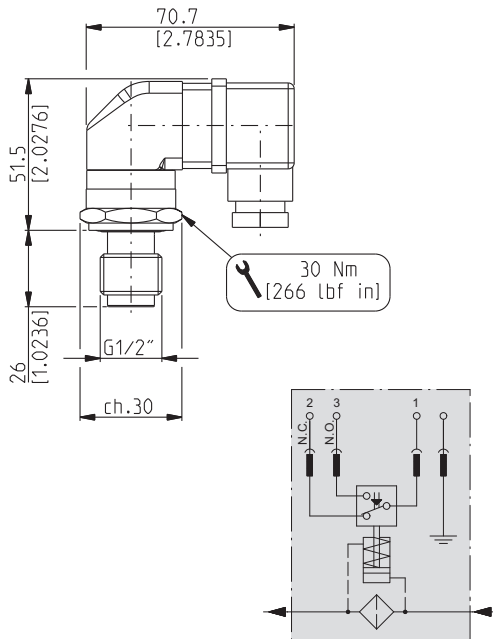

ICAT_011_007_HF760

Differential pressure setting 116 psi (8 bar)

Max. working voltage 250 VAC
30 VCC

Max. working current 5 A (resistivity)
5 A (inductive)

Protection class IP 65

VISUAL ELECTRICAL DIFFERENTIAL WITH THERMOSTAT

Code: **W**

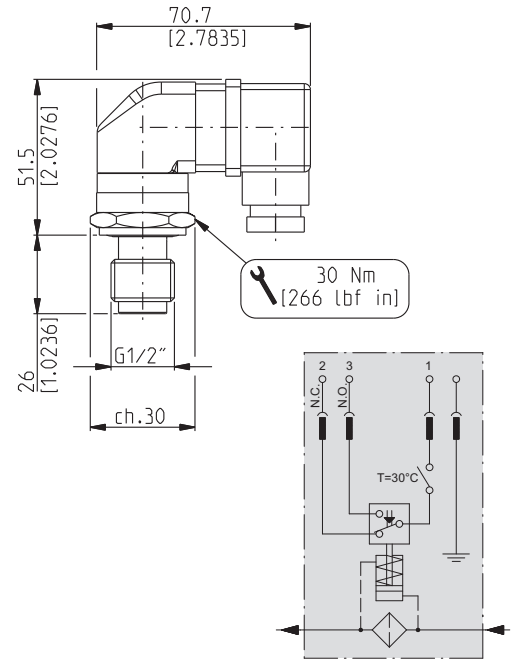

ICAT_011_007_HF760

Differential pressure setting 116 psi (8 bar)

Max. working voltage 250 VAC
30 VCC

Max. working current 5 A (resistivity)
5 A (inductive)

Protection class IP 65

Min. function temperature 86 °F (30 °C)

01/02.2009

ASSEMBLY AND REPLACING ELEMENT INSTRUCTIONS

ASSEMBLY

Once you have checked the integrity of the filter inside its package, proceed as follows:

- A Take the protection caps off the oil inlet and outlet.
- B Make sure that all the O-rings have been situated in the inlet flange which matches with the starting block. If the filter provides a clogging indicator (pos. 8 - 9 - 10), take the protection cap off and screw the indicator in the dedicated seat, then tighten to a tightening torque of 266 lbf in (30 Nm).
- C The assembly of the filter and its eventual valves has to be made with stay bolts of eligible resistance class. The tightening torque needs to consider the instructions reported for each of the components.
- D If the filter provides an electrical indicator (pos. 9 - 10), make sure that all the necessary connections have been done.
- E Start the circuit for a few minutes until getting the achievement of the system's maximum pressure.
- F Make sure there are no leaks.

REPLACING ELEMENT

Once the working hours limit indicated in the maintenance instructions of the system is reached, or when the clogging indicators point out the limit pressure drop created inside the filter, the cartridge must be replaced, remembering that this procedure involves the drainage of hydraulic oil and therefore you need to prepare suitable containers to collect the oil.

Proceed as follows:

- A Stop the system in "Machine stopped" status.
- B Secure any shut-off valves on the hydraulic circuit.
- C Unscrew the filter container (pos.1) using the maximum care, in order to avoid stay bolts' deformations.
- D Remove the clogged filtering cartridge, making sure no residual particles have settled on the bottom (pos.5).
- E Make sure the O-ring (pos.2 - pos.4) and the anti-extrusion ring (pos.3) are not damaged, otherwise replace them and consequently position the new ones correctly.
- F Insert the new filtering cartridge, lubricating the sealing O-ring beforehand.
- G Screw the container tight (pos.1) making sure the threading is screwed correctly. Tighten to a tightening torque of 443 lbf in (50 Nm) using the maximum care, in order to avoid stay bolts' deformations.
- H Start the machine for a few minutes.
- I Make sure there are no leaks.

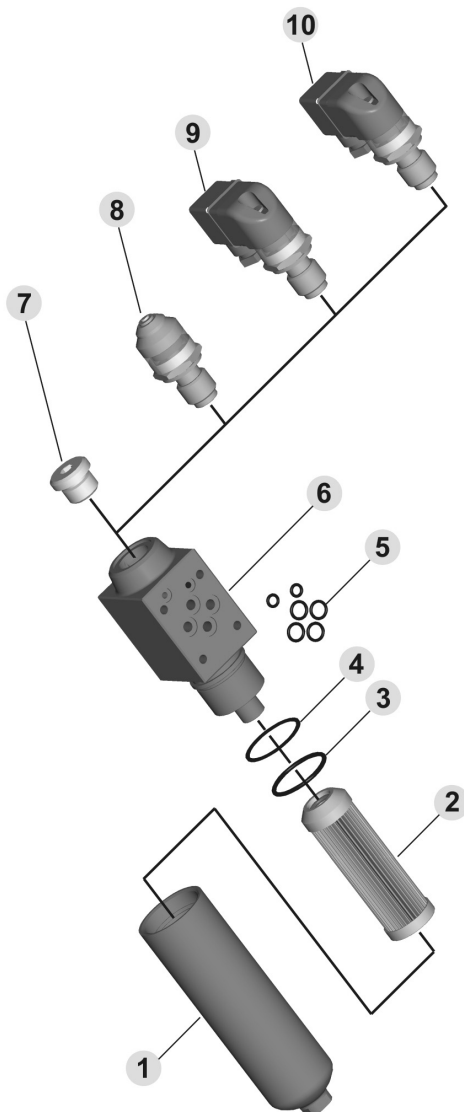

Pos. Description

- 1 Filter bowl
- 2 Filtering element
- 3 Anti-extrusion ring
- 4 Sealing O-Ring
- 5 Filtering element
- 6 Filter head
- 7 By-pass valve
- 8 Sealing cap
- 9 Visual differential indicator
- 10 Visual electrical differential indicator
- 11 Visual electrical differential indicator with thermostat

When ordering spare parts, always specify the reference number, the filter code and quantity.

Example: Spare part pos. 4 - HHP39500 - Qty 2

01/02.2009

HOW TO ORDER A COMPLETE FILTER

1

2

3

4

5

6

7

8

9

HF725 10.100 - AS - FG010 - HC - B00 - B - XD - H - A

1	Filter type	CODE
	See dimensions from pag. 6	HF725 10.100

2	Filtering surface	CODE
	Standard	AS

3	Degree of filtration	CODE
	3 [µm] Micro-fibre glass	FG003
	6 [µm] Micro-fibre glass	FG006
	10 [µm] Micro-fibre glass	FG010
	25 [µm] Micro-fibre glass	FG025
	10 [µm] Stainless steel	MI010
	25 [µm] Stainless steel	MI025

4	Δp collapse pressure	CODE
	3046 [psi] (210 [bar])	HC

5	By-pass valve	CODE
	Without	B00

6	Seals	CODE
	Buna	B
	Viton	V

7	Indicator arrangement	CODE
	Without	XN
	Arranged	XD
	Arranged with plug	DD

8	Indicators	CODE
	Without	G
	Visual differential indicator	H
	Visual electrical differential indicator	U
	Visual electrical differential indicator with thermostat	W

9	Version	CODE
	Right	A
	Left	B

	Standard
--	----------

	On request
--	------------

HOW TO ORDER A REPLACEMENT ELEMENT

1	2	3	4	5
HE K85	10.100	-	AS	-
		-	FG010	-
			HC	-
				B

1	Element type	CODE
	See table pag. 7	HE K85 10.100

4	Δp collapse pressure	CODE
	3046 [psi] (210 [bar])	HC

2	Filtering surface	CODE
	Standard	AS

5	Seals	CODE
	Buna	B
	Viton	V

3	Degree of filtration	CODE
	3 [μm] Micro-fibre glass	FG003
	6 [μm] Micro-fibre glass	FG006
	10 [μm] Micro-fibre glass	FG010
	25 [μm] Micro-fibre glass	FG025
	10 [μm] Stainless steel	MI010
	25 [μm] Stainless steel	MI025

Standard
 On request

Building & construction

Agriculture

Truck Market

Material Handling

Industrial

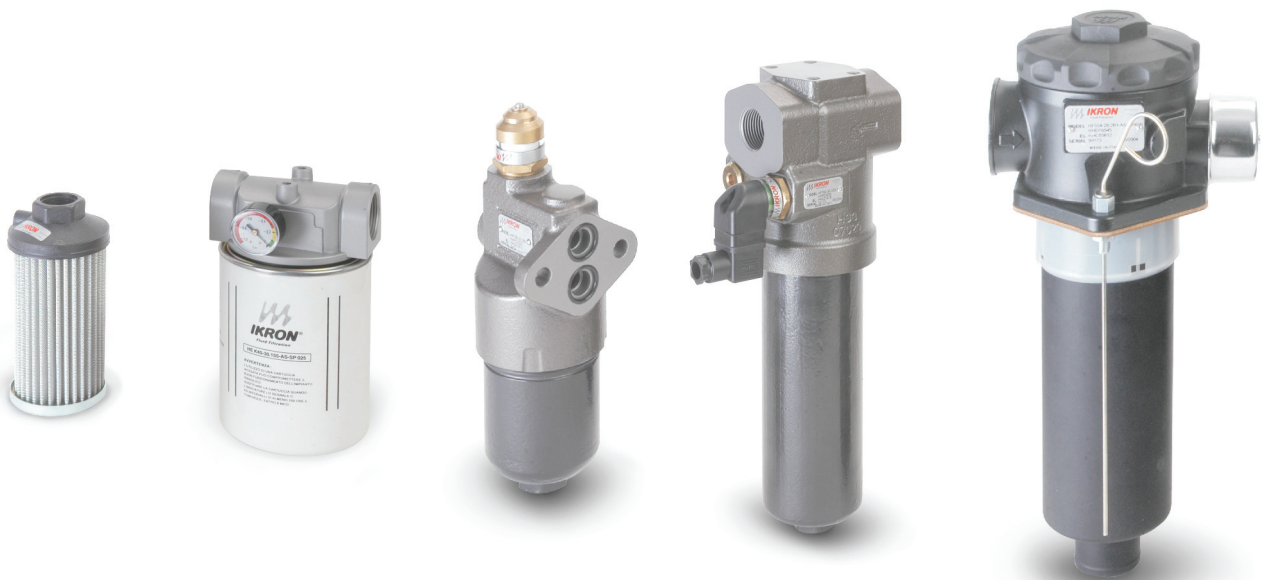

Full range of filters
for all hydraulic circuits

Suction filters

HF 410

Tank mounted return line filters

HF 502

HF 547

HF 554

HF 570

HF 575

In line filters Spin-On

HF 620

HF 625

HF 650

In line medium and high pressure filters

HF 690

HF 705

HF 725

HF 735

HF 745

HF 760

HF 761

Accessories

Filler breathers

Air filters

Level and temperature gauges

Pressure gauges

Pressure/vacuum gauges

Clogging indicators



IKRON S.r.l.

Via Prampolini, 2 - 43044 Lemignano di Collecchio - Parma - Italy

Tel.: + 39 0521 304911 - Fax: + 39 0521 304900

www.ikron.it

E-mail: info@ikron.it



Replaces: HF 725 01 T E

HF 725 01 T A Edition: 01/02.2009

