

Symbol

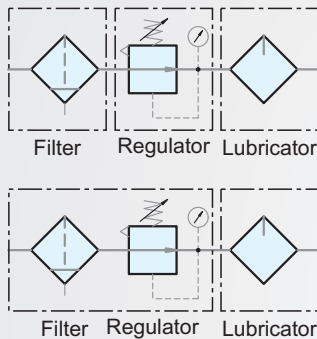

Features

- * Remove water and particle effectively.
- * Compact size with effective air service.
- * 40 μm and 5 μm filter element are easily interchangeable and replaceable.
- * Accurate and easy pressure setting.
- * Oil spray in mist ensures good lubrication for machines.

How to order

FRL700B — 02 N C H K

FRL700B	Miniature Filter+Regulator+Lubricator
FRL600B	Miniature Filter Regulator+Lubricator

Port size		Thread		Filtration		Drain		Bowl guard	
01	1/8" Option	Blank	PS	Blank	5 μm	Blank	Semi-auto drain	Blank	W/O guard
		N	NPT	C	40 μm	H	Manual drain	K	W/I guard
02	1/4" Standard								

Specifications

Model	FRL700B-01	FRL700B-02	FRL600B-01	FRL600B-02
Port size	1/8" (Option)	1/4" (Standard)	1/8" (Option)	1/4" (Standard)
Fluid	Compressed air			
Regulator construction	Piston			
Body material	Aluminum die-cast			
Bowl material	Polycarbonate (Standard)			
Filtration	5 μm (Standard) · 40 μm (Option)			
Operating pressure range	0.5 ~ 10 kgf/cm ²			
Max. inlet pressure (Standard bowl)	12 kgf/cm ²			
Max. flow rate l/min (6kgf/cm ²)	1875		1750	1850
Ambient temperature	-10°C ~ 60°C			
Lubricator oil (Recommended)	ISO-VG32			
Filter bowl capacity	40cc			
Lubricator bowl capacity	50cc			
Standard drain	Semi-auto drain (Drains below 0.5kgf/cm ²)			
Net weight	765g		560g	
Accessories	Pressure gauge, Mounting bracket, Plug, Screw x 2			

Dimensions

FRL700B-01, 02

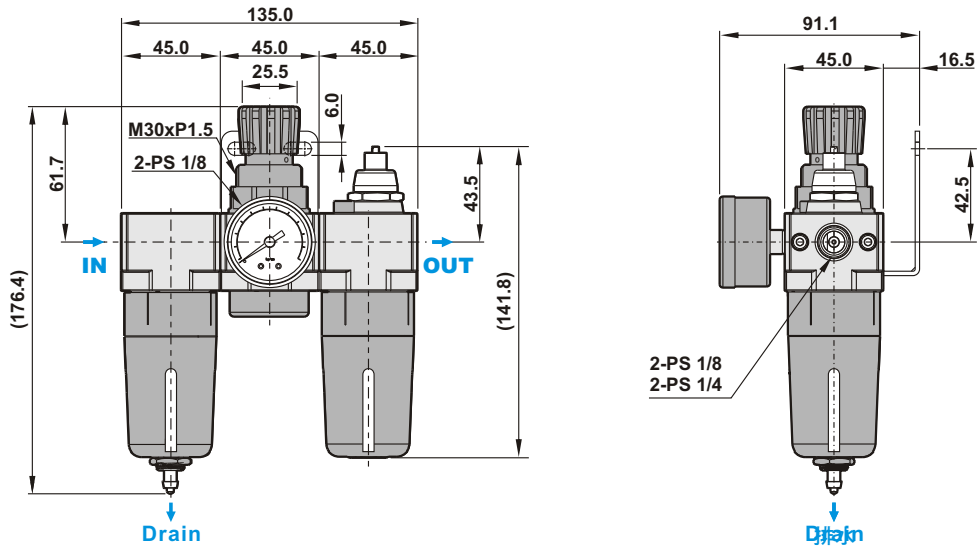

FRL600B-01, 02

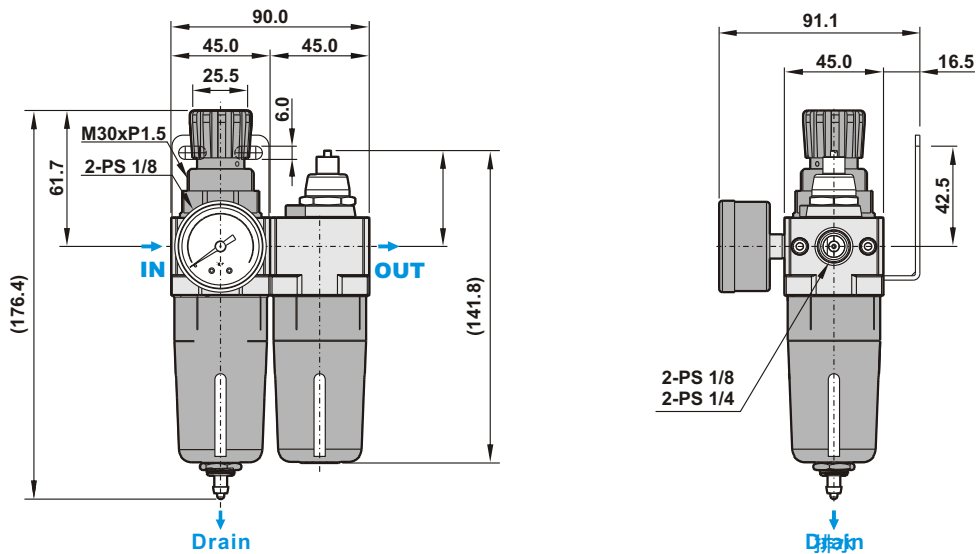

Flow chart

Model: FRL700B

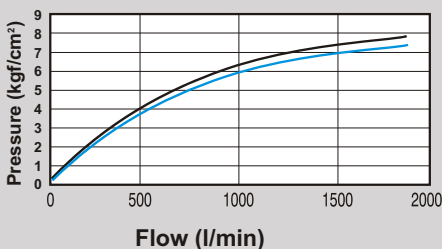

Model: FRL600B

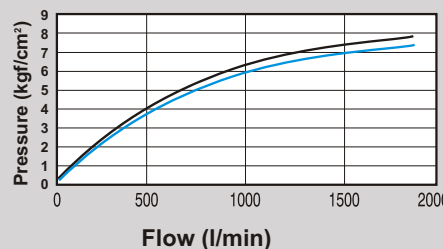

Note:

- X axis: Flow
- Y axis: Pressure
- Blue line (P0) = Outlet pressure
- Black line (P1) = Inlet pressure
- P1-P0 = Pressure range

Construction

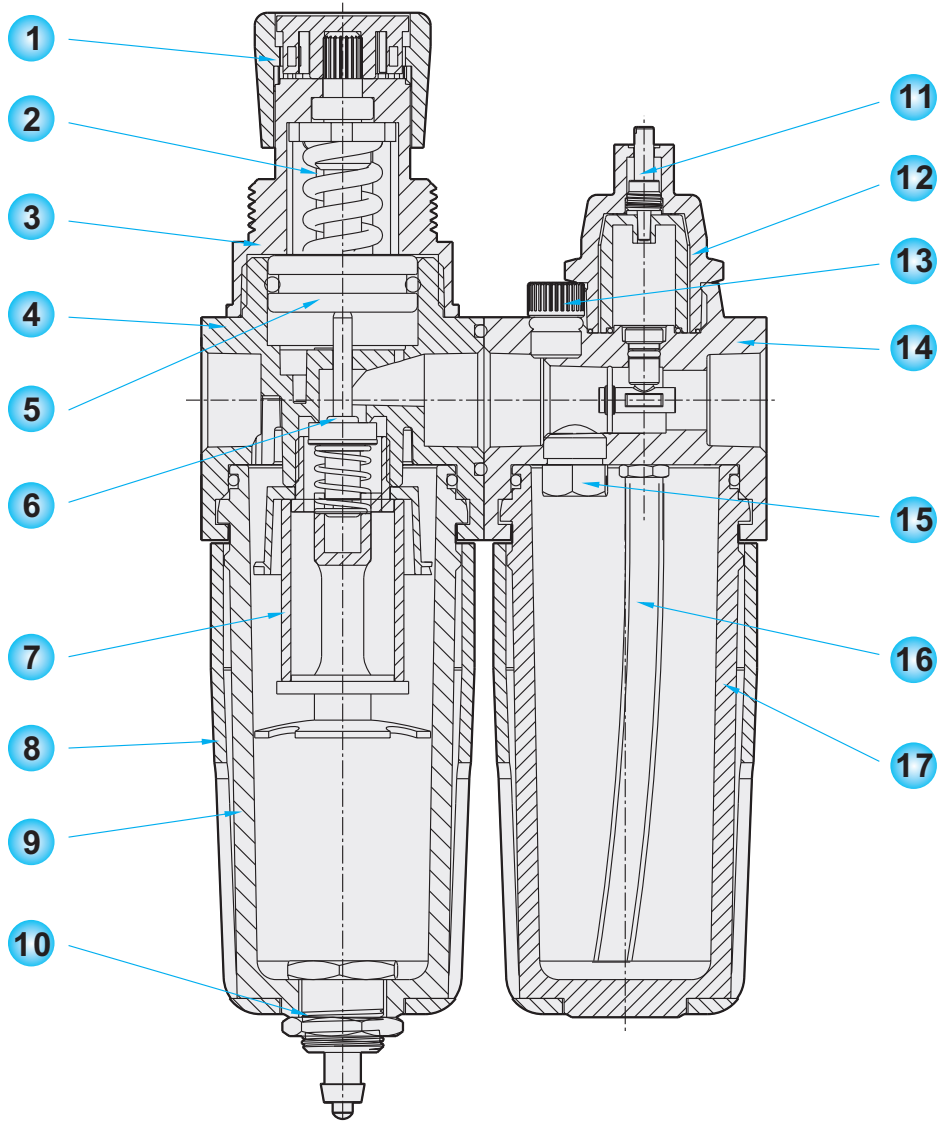

No.	Description	Material
1	Pressure regulating knob	NY
2	Spring	Spring steel+Ni
3	Regulator base	NY+GF
4	Regulator body	AL(ADC12)
5	Piston	AL(ADC12)
6	Pressure regulating needle	Cu+NBR
7	Filter element holder	Cu
8	Bowl guard	NY+GY
9	Filter bowl	PC

No.	Description	Material
10	Semi-auto drain	Cu+Ni
11	Oil adjusting screw	Cu+Ni
12	Oil viewer	GV4H
13	Oil filling plug	Cu+Ni
14	Lubricator body	AL(ADC12)
15	Check valve	Cu
16	Oil pipe	PU
17	Lubricator bowl	PC

Symbol

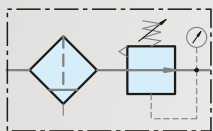

Filter Regulator

Features

- * Remove water and particle effectively.
- * Compact size with effective air service.
- * 40 μm and 5 μm filter element are easily interchangeable and replaceable.
- * Accurate and easy pressure setting.



How to order

FR500B

02

N

C

H

K

Miniature Filter Regulator		Port size		Thread		Filtration		Drain		Bowl guard	
FR	Filter Regulator	01	02	Blank	N	Blank	C	Blank	H	Blank	K
		1/8" Option	1/4" Standard	PS	NPT	5 μm	40 μm	Semi-auto drain	Manual drain	W/O guard	W/I guard

Specifications

Model	FR500B-01	FR500B-02
Port size	1/8" (Option)	1/4" (Standard)
Fluid	Compressed air	
Regulator construction	Piston	
Body material	Aluminum die-cast	
Bowl material	Polycarbonate (Standard)	
Filtration	5 μm (Standard) 、 40 μm (Option)	
Operating pressure range	0.5 ~ 10 kgf/cm ²	
Max. inlet pressure (Standard bowl)	12 kgf/cm ²	
Max. flow rate l/min (6kgf/cm ²)	1800	1880
Ambient temperature	-10°C ~ 60°C	
Filter bowl capacity	40cc	
Standard drain	Semi-auto drain (Drains below 0.5kgf/cm ²)	
Net weight	365g	
Accessories	Pressure gauge, Mounting bracket, Plug, Screw x 2	

Dimensions

FR500B-01, 02

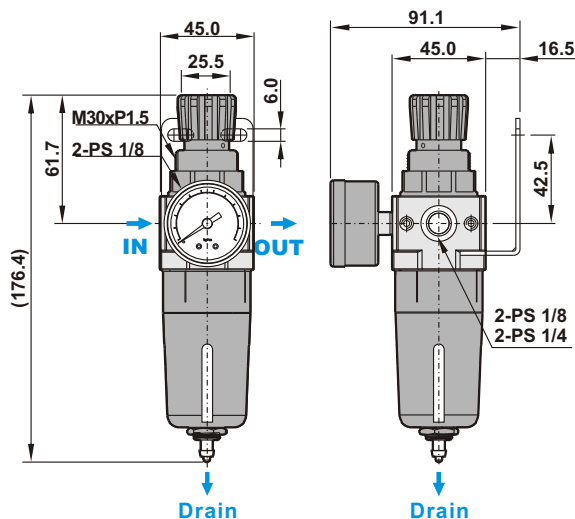

Flow chart

Model: FR500B

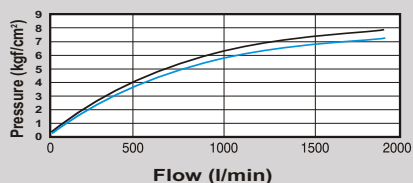

Note:

X axis: Flow
Y axis: Pressure

Blue line (P0) = Outlet pressure
Black line (P1) = Inlet pressure
P1-P0 = Pressure range

Symbol

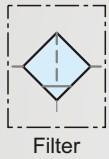

Features

- * Remove water and particle effectively.
- * Compact size with effective air service.
- * 40 μm and 5 μm filter element are easily interchangeable and replaceable.



How to order

F200B	02	N	C	H	B	K					
Miniature Filter	Port size	Thread		Filtration		Drain	Mounting bracket	Bowl guard			
01	1/8" Option	Blank	PS	Blank	5 μm	Blank	Semi-auto drain	Blank	W/O bracket	Blank	W/O guard
02	1/4" Standard	N	NPT	C	40 μm	H	Manual drain	B	W/I bracket	K	W/I guard

Specifications

Model	F200B-01	F200B-02
Port size	1/8" (Opti on)	1/4" (Stan dard)
Fluid	Compressed air	
Body material	Aluminum die-cast	
Bowl material	Polycarbonate (Standard)	
Filtration	5 μm (Standard) ~ 40 μm (Option)	
Operating pressure range	0.5 ~ 10 kgf/cm ²	
Max. inlet pressure (Standard bowl)	12 kgf/cm ²	
Max. flow rate l/min (6kgf/cm ²)	1900	
Ambient temperature	-10℃ ~ 60℃	
Filter bowl capacity	40cc	
Standard drain	Semi-auto drain (Drains below 0.5kgf/cm ²)	
Net weight	245g	
Accessories	Mounting bracket, Screw x 2	

Dimensions

F200B-01, 02

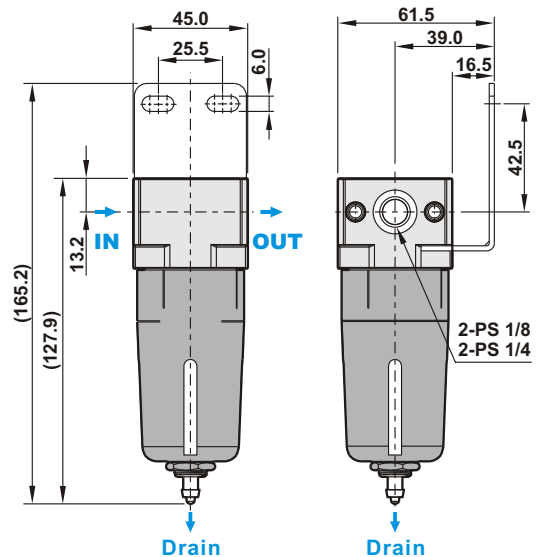

Flow chart

Model: F200B

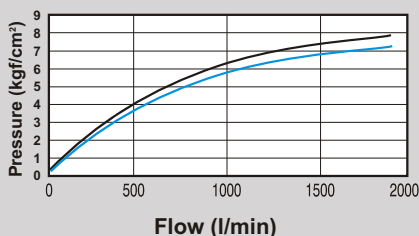

Note:

X axis: Flow
Y axis: Pressure

Blue line (P0) = Outlet pressure
Black line (P1) = Inlet pressure
P1-P0 = Pressure range

Symbol

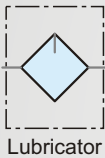

Features

* Oil spray in mist ensures good lubrication for machines.



How to order

L200B

Miniature lubricator

02

Port size

01	1/8" Option
02	1/4" Standard

N

Thread

Blank	PS
N	NPT

B

Mounting bracket

Blank	W/O bracket
B	W/I bracket

K

Bowl guard

Blank	W/O guard
K	W/I guard

Specifications

Model	L200B-01	L200B-02
Port size	1/8" (Option)	1/4" (Standard)
Fluid	Compressed air	
Body material	Aluminum die-cast	
Bowl material	Polycarbonate (Standard)	
Operating pressure range	0.5 ~ 10 kgf/cm ²	
Max. inlet pressure	12 kgf/cm ²	
Max. flow rate l/min (6kgf/cm ²)	2490	
Ambient temperature	-10°C ~ 60°C	
Lubricator oil (Recommended)	ISO-VG32	
Lubricator bowl capacity	50cc	
Net weight	245g	
Accessories	Mounting bracket, Screw x 2	

Dimensions

L200B-01, 02

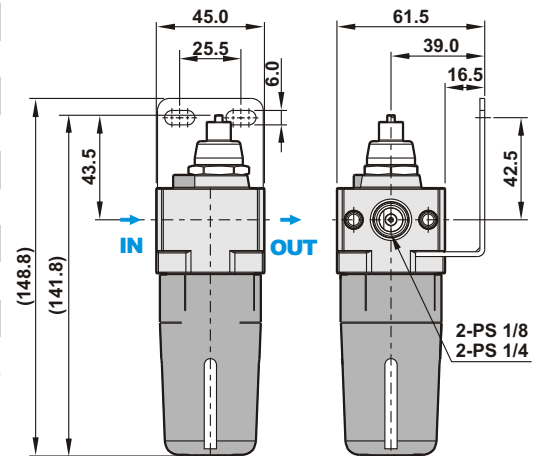

Flow chart

Model: L200B

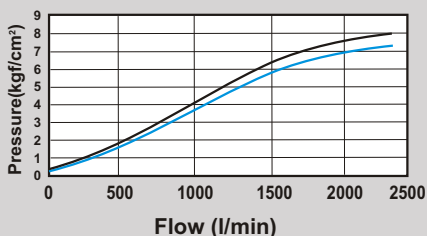

Note:

X axis: Flow
Y axis: Pressure

Blue line (P0) = Outlet pressure
Black line (P1) = Inlet pressure
P1-P0 = Pressure range

Symbol

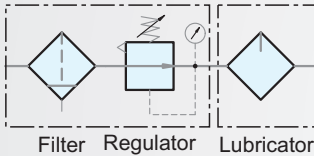
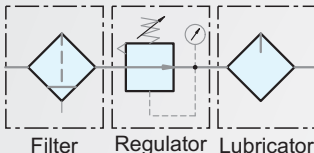

Features

- * Remove water and particle effectively.
- * Compact size with effective air service.
- * 40 μm and 5 μm filter element are easily interchangeable and replaceable.
- * Accurate and easy pressure setting.
- * Oil spray in mist ensures good lubrication for machines.
- * Strict quality control offers product stable quality and long life.

Miniature FRL A type patent
 Patent number in Taiwan: 1888494
 Patent number in the US.: US6.733.044
 Patent number in China: 538716

How to order

FRL700A

02

N

C

H

K

FRL700A	Miniature Filter+Regulator+Lubricator
FRL600A	Miniature Filter Regulator+Lubricator

Port size		Thread		Filtration		Drain		Bowl guard	
01	1/8" Option	Blank	PS	Blank	5 μm	Blank	Semi-auto drain	Blank	W/O guard
02	1/4" Standard	N	NPT	C	40 μm	H	Manual drain	K	W/I guard

Specifications

Model	FRL700A-01	FRL700A-02	FRL600A-01	FRL600A-02
Port size	1/8" (Option)	1/4" (Standard)	1/8" (Option)	1/4" (Standard)
Fluid	Compressed air			
Regulator construction	Diaphragm			
Body material	Polycarbonate			
Bowl material	Polycarbonate (Standard)			
Filtration	5 μm (Standard) · 40 μm (Option)			
Operating pressure range	0.5 ~ 10 kgf/cm ²			
Max. inlet pressure (Standard bowl)	12 kgf/cm ²			
Max. flow rate l/min (6kgf/cm ²)	1850		1650	1850
Ambient temperature	-10°C ~ 60°C			
Lubricator oil (Recommended)	ISO-VG32			
Filter bowl capacity	35cc			
Lubricator bowl capacity	50cc			
Standard drain	Semi-auto drain (Drains below 0.5kgf/cm ²)			
Net weight	810g		560g	
Accessories	Pressure gauge, Mounting bracket, Plug, Screw x 2			

Dimensions

FRL700A-01, 02

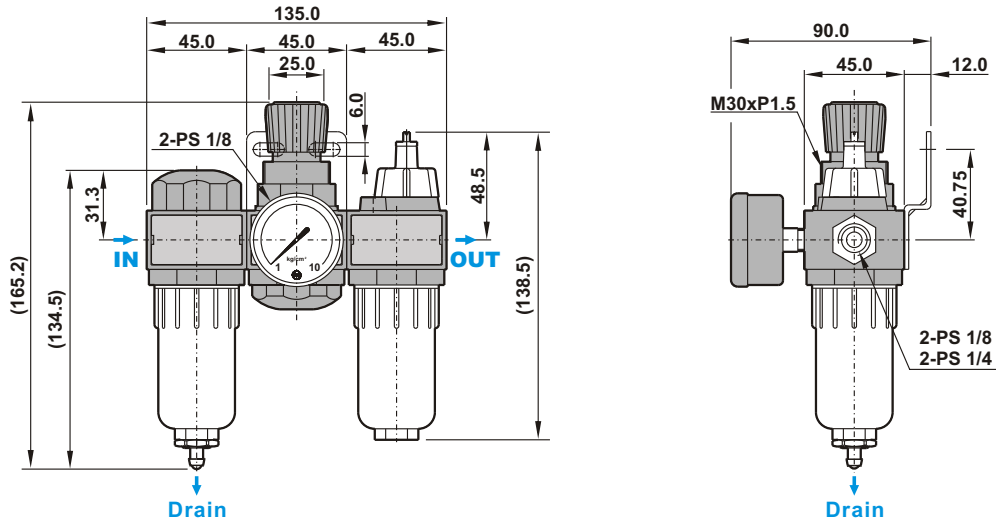

FRL600A-01, 02

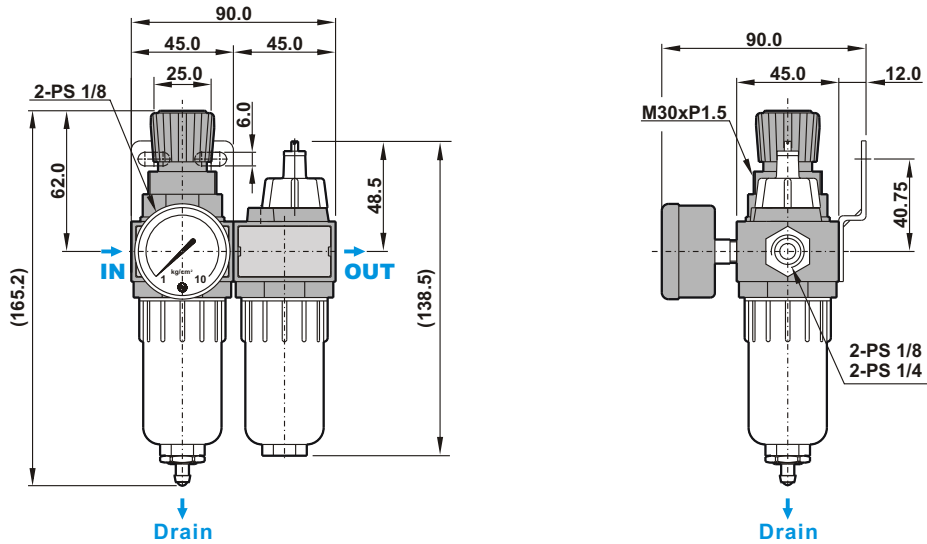

Flow chart

Model: FRL700A

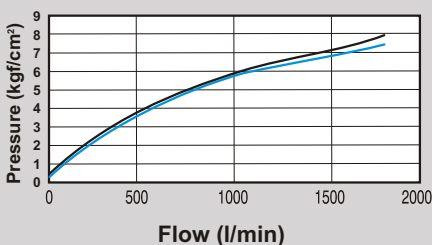

Model: FRL600A

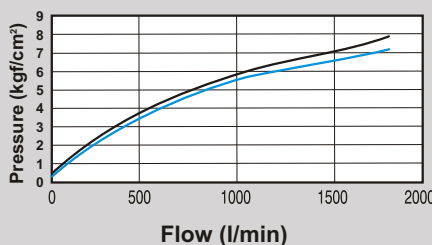

Note:

- X axis: Flow
- Y axis: Pressure
- Blue line (P0) = Outlet pressure
- Black line (P1) = Inlet pressure
- P1-P0 = Pressure range

Symbol

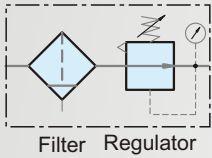

Filter Regulator

Features

- * Remove water and particle effectively.
- * Compact size with effective air service.
- * 40 μ m and 5 μ m filter element are easily interchangeable and replaceable.
- * Accurate and easy pressure setting.

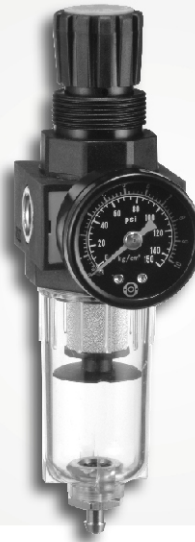

How to order

FR500A	—	02	N	C	H	K
Miniature Filter Regulator		Port size	Thread	Filtration	Drain	Bowl guard
		01 1/8" Option 02 1/4" Standard	Blank PS N NPT	Blank 5 μ m C 40 μ m	Blank Semi-auto drain H Manual drain	Blank W/O guard K W/I guard

Specifications

Model	FR500A-01	FR500A-02
Port size	1/8" [Option]	1/4" [Standard]
Fluid	Compressed air	
Regulator construction	Diaphragm	
Body material	Polycarbonate	
Bowl material	Polycarbonate (Standard)	
Filtration	5 μ m (Standard) 、 40 μ m (Option)	
Operating pressure range	0.5 ~ 10 kgf/cm ²	
Max. inlet pressure (Standard bowl)	12 kgf/cm ²	
Max. flow rate l/min (6kgf/cm ²)	1840	1940
Ambient temperature	-10 $^{\circ}$ C ~ 60 $^{\circ}$ C	
Filter bowl capacity	35cc	
Standard drain	Semi-auto drain (Drains below 0.5kgf/cm ²)	
Net weight	370g	
Accessories	Pressure gauge, Mounting bracket, Plug, Screw x 2	

Dimensions

FR500A-01, 02

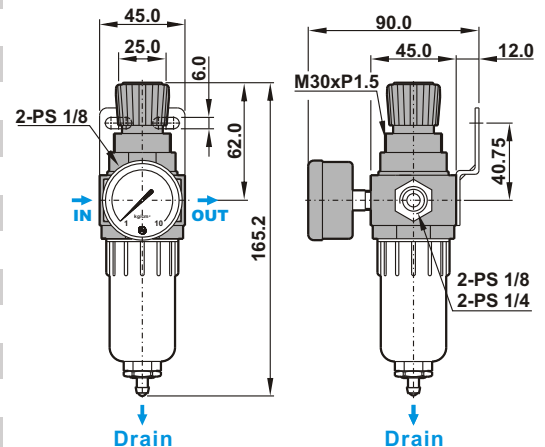

Flow chart

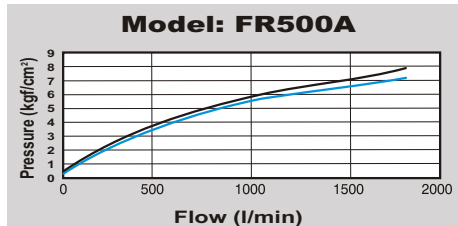

Note:

- X axis: Flow
- Y axis: Pressure
- Blue line (P0) = Outlet pressure
- Black line (P1) = Inlet pressure
- P1-P0=Pressure range

Symbol

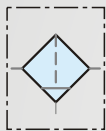

Filter

Features

- * Remove water and particle effectively.
- * Compact size with effective air service.
- * 40 μm and 5 μm filter element are easily interchangeable and replaceable.



How to order

F200A	-	02	N	C	H	B	K
Miniature Filter		Port size	Thread	Filtration	Drain	Mounting bracket	Bowl guard
		01 1/8" Option 02 1/4" Standard	Blank PS N NPT	Blank 5 μm C 40 μm	Blank Semi-auto drain H Manual drain	Blank W/O bracket B W/I bracket	Blank W/O guard K W/I guard

Specifications

Model	F200A-01	F200A-02
Port size	1/8" (Option)	1/4" (Standard)
Fluid	Compressed air	
Body material	Polycarbonate	
Bowl material	Polycarbonate (Standard)	
Filtration	5 μm (Standard) - 40 μm (Option)	
Operating pressure range	0.5 ~ 10 kgf/cm ²	
Max. inlet pressure (Standard bowl)	12 kgf/cm ²	
Max. flow rate l/min (6kgf/cm ²)	1900	
Ambient temperature	-10°C ~ 60°C	
Filter bowl capacity	35cc	
Standard drain	Semi-auto drain (Drains below 0.5kgf/cm ²)	
Net weight	245g	
Accessories	Mounting bracket, Screw x 2	

Dimensions

F200A-01, 02

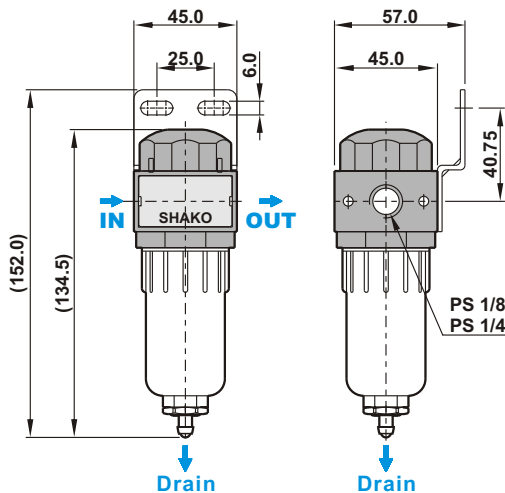

Flow chart

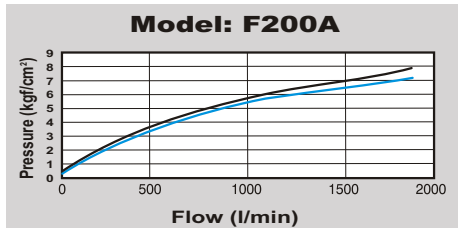

Note:

- X axis: Flow
- Y axis: Pressure
- Blue line (P0) = Outlet pressure
- Black line (P1) = Inlet pressure
- P1-P0 = Pressure range

Symbol

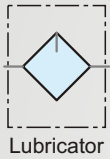

Features

- * Compact size with effective air service.
- * Oil spray in mist ensures good lubrication for machines.



How to order

L200A

Miniature lubricator

02

Port size

01	1/8" Option
02	1/4" Standard

N

Thread

Blank	PS
N	NPT

B

Mounting bracket

Blank	W/O bracket
B	W/I bracket

K

Bowl guard

Blank	W/O guard
K	W/I guard

Specifications

Model	L200A-01	L200A-02
Port size	1/8" (Option)	1/4" (Standard)
Fluid	Compressed air	
Body material	Polycarbonate	
Bowl material	Polycarbonate (Standard)	
Operating pressure range	0.5 ~ 10 kgf/cm ²	
Max. inlet pressure	12 kgf/cm ²	
Max. flow rate l/min (6kgf/cm ²)	2449	
Ambient temperature	-10°C ~ 60°C	
Lubricator oil (Recommended)	ISO-VG32	
Lubricator bowl capacity	50cc	
Net weight	165g	
Accessories	Mounting bracket, Screw x 2	

Flow chart

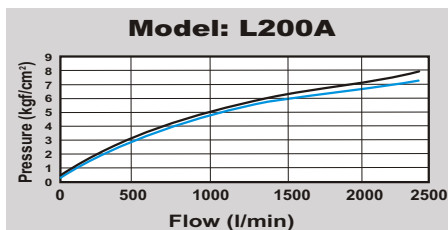

Dimensions

L200A-01, 02

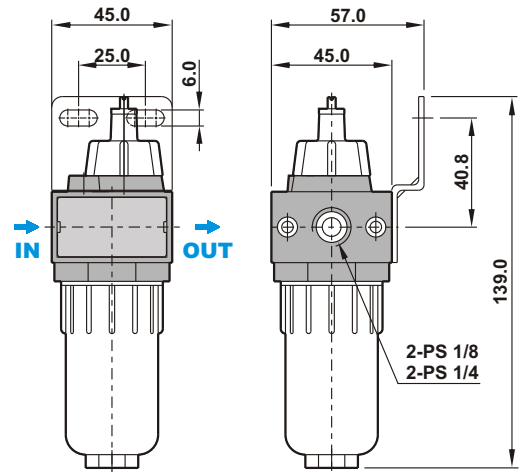

Note:

- X axis: Flow
- Y axis: Pressure
- Blue line (P0) = Outlet pressure
- Black line (P1) = Inlet pressure
- P1-P0 = Pressure range

Symbol

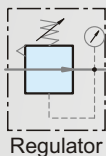

Features

- * Accurate and easy pressure setting.
- * Panel mounting is available.



How to order

R200	—	02	N	B	G
R200 Miniature Regulator		Port size	Thread	Mounting bracket	Pressure gauge
		01 1/8"	Blank PS	Blank W/O bracket	Blank W/O gauge
		02 1/4"	N NPT	B W/I bracket	G W/I gauge

Specifications

Model	R200
Port size	1/8", 1/4"
Fluid	Compressed air
Regulator construction	Piston
Body material	Aluminum die-cast
Operating pressure range	0.5 ~ 8 kgf/cm ²
Max. inlet pressure	9.9 kgf/cm ²
Max. flow rate l/min (6kgf/cm ²)	1550
Ambient temperature	-10°C ~ 60°C
Net weight	205g
Accessories	Plug

Flow chart

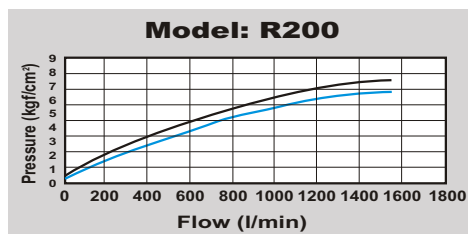

Note:

- X axis: Flow
- Y axis: Pressure
- Blue line (P0) = Outlet pressure
- Black line (P1) = Inlet pressure
- P1-P0 = Pressure range

Dimensions

R200-01, 02

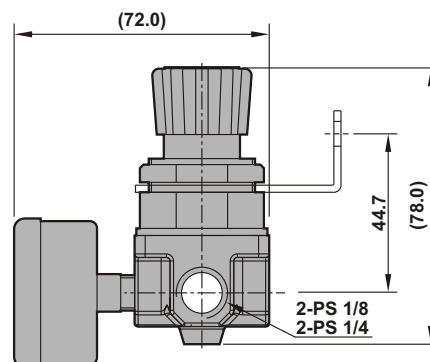
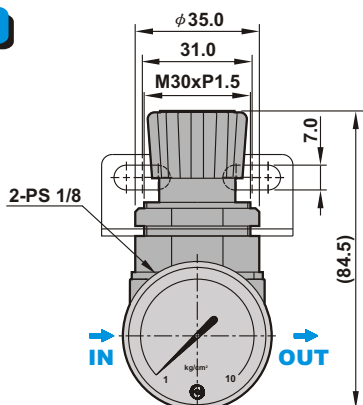

Symbol

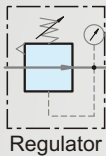

Features

- * Diaphragm design provides more accurate and easier pressure setting.
- * Panel mounting is available.



How to order

NR200

02

N

B

G

NR200	Operating pressure 0.5~8kgf/cm ²	Port size	Thread	Mounting bracket	Pressure gauge
NR200L4	Operating pressure 0~4kgf/cm ²	01 1/8"	Blank PS	Blank W/O bracket	Blank W/O gauge
NR200L2	Operating pressure 0~2 kgf/cm ²	02 1/4"	N NPT	B W/I bracket	G W/I gauge

Specifications

Model	NR200	NR200L4	NR200L2
Port size	1/8", 1/4"		
Fluid	Compressed air		
Regulator construction	Diaphragm		
Body material	Aluminum die-cast		
Operating pressure range	0.5~8 kgf/cm ²	0~4 kgf/cm ²	0~2 kgf/cm ²
Max. inlet pressure	12 kgf/cm ²		
Max. flow rate l/min (6kgf/cm ²)	1500		
Ambient temperature	-10°C ~ 60°C		
Net weight	205g		
Accessories	Plug		

Flow chart

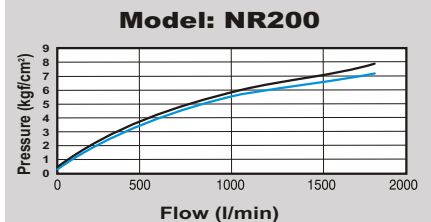

Note:

X axis: Flow
 Y axis: Pressure
 Blue line (P0) = Outlet pressure
 Black line (P1) = Inlet pressure
 P1-P0 = Pressure range

Dimensions

NR200-01, 02

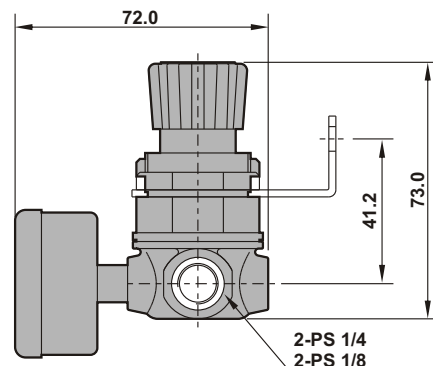
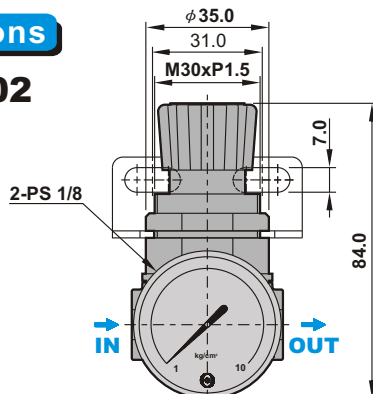

Construction

R200-01, 02

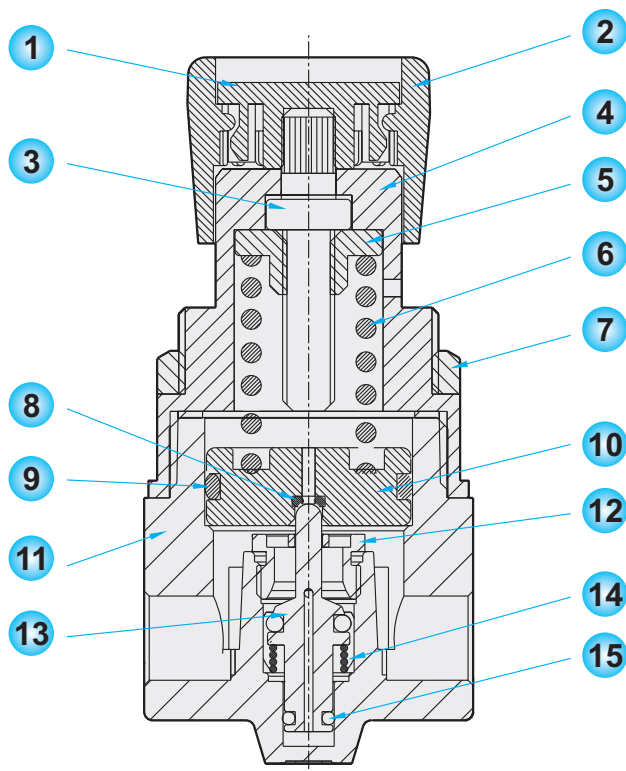

No.	Description	Material
1	Regulator dome	NY
2	Regulator knob	NY
3	Pressure regulating screw	Fe+Ni
4	Regulator base	NY+GF
5	Pressure regulating nut	Cu+Ni
6	Spring	Spring steel
7	Lock nut	NY+GF
8	O-ring	NBR
9	O-ring	NBR
10	Piston	AL
11	Body	ADC12
12	Positioning nut	Cu
13	Regulating needle	Cu
14	Spring	SUS
15	O-ring	NBR

NR200-01, 02

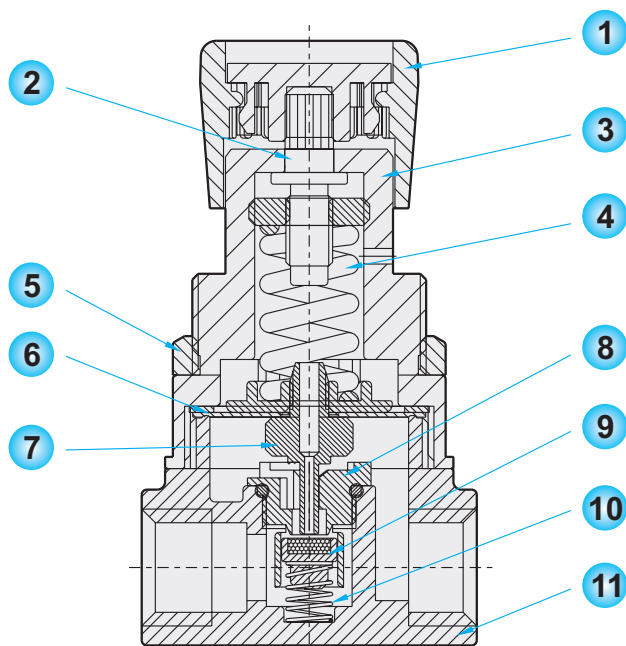

No.	Description	Material
1	Regulator knob	NY
2	Pressure regulating screw	Fe+Ni
3	Regulator base	NY+GF
4	Spring	Spring steel
5	Lock nut	NY+GF
6	Diaphragm	NBR70 ⁺
7	Regulating needle	AL
8	Positioning nut	POM
9	Plug	Cu
10	Spring	SUS
11	Body	ADC12