

B

MODULAR (STACK) VALVES

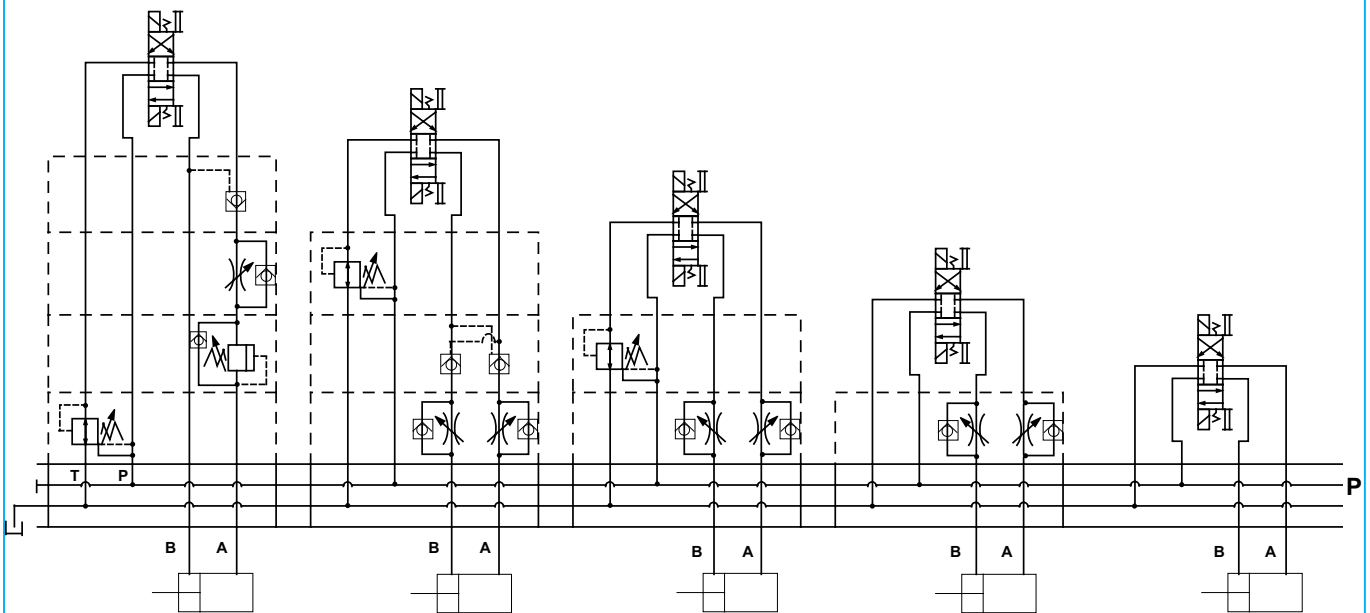



SOLTECH

MODULAR(STACK) CONTROLS

MODULAR(STACK) VALVES

【 GRAPHICAL SYMBOLS 】

B

Class	Model No.	Graphical Symbols	Page	Class	Model No.	Graphical Symbols	Page
Solenoid Operated Directional Valve	SWG-02-※※※※※		♣	Sol. Oprd. Directional Valve	P T B A	♣	
	SWG-03-※※※※※						
Pressure Control Valves	Relief Valve (for "P-Line") MR-02-P-※ MR-03-P-※		30 --- 32	Flow Control Valves	Throttle And Check Valve (for "A-Line, Meter In") MTC-02-A-IN※ MTC-03-A-IN※		38 --- 40
	Relief Valve (for "A-Line") MR-02-A-※ MR-03-A-※		30 --- 32		Throttle And Check Valve (for "B-Line, Meter out") MTC-02-B-※ MTC-03-B-※		38 --- 40
	Relief Valve (for "B-Line") MR-02-B-※ MR-03-B-※		30 --- 32		Throttle And Check Valve (for "B-Line, Meter In") MTC-02-B-IN※ MTC-03-B-IN※		38 --- 40
	Relief Valve (for "A & B-Line") MR-02-W-※ MR-03-W-※		30 --- 32		Throttle And Check Valve (for "A,B-Line, Meter out") MTC-02-W-※ MTC-03-W-※		38 --- 40
	Reducing Valve (for "P-Line") MPR-02-P-※ MPR-03-P-※		34 --- 36		Throttle And Check Valve (for "A,B-Line, Meter In") MTC-02-W-IN※ MTC-03-W-IN※		38 --- 40
	Reducing Valve (for "A-Line") MPR-02-A-※ MPR-03-A-※		34 --- 36		Directional Control Valves		Check Valve MC-02-P-※ MC-03-P-※
	Reducing Valve (for "B-Line") MPR-02-B-※ MPR-03-B-※		34 --- 36	Check Valve MC-02-T-※ MC-03-T-※		46 --- 48	
	Counter-Balance Valve (for "A-Line") MSCV-02-A-※ MSCV-03-A-※		42 --- 44	Check Valve MC-02-B-※ MC-03-B-※		46 --- 48	
	Counter-Balance Valve (for "B-Line") MSCV-02-B-※ MSCV-03-B-※		42 --- 44	Check Valve MC-02-A-※ MC-03-A-※		46 --- 48	
	Pressure Switches Vavle (for "P-Line") MJCS-2P-※ MJCS-3P-※		38 --- 40	Pilot Operated Check Valve MPC-02-A-※ MPC-03-A-※		50 --- 52	
	Pressure Switches Vavle (for "A-Line") MJCS-2A-※ MJCS-3A-※			Pilot Operated Check Valve MPC-02-B-※ MPC-03-B-※		50 --- 52	
	Pressure Switches Vavle (for "P-Line") MJCS-2B-※ MJCS-3B-※		38 --- 40	Pilot Operated Check Valve MPC-02-W-※ MPC-03-W-※	50 --- 52		
	Throttle Valve (for "P-Line") MT-02-P-※ MT-03-P-※				End Plates (Blocking Plates) MDC-02-※	54	
	Throttle And Check Valve (for "A-Line, Meter out") MTC-02-A-※ MTC-03-A-※						End Plates (Bypass plates) MDC-03-※
	Modular Plates and Mounting Bolts				Base Plates MMC-02-※ MMC-03-※	55 --- 56	
			Bolt Kits MBK-02 MBK-03				57



SOLTECH

MODULAR(STACK) CONTROLS

MODULAR(STACK) VALVES

[INSTRUCTIONS]

Caution in the selection of valves and circuit designing

The selection of modular valves, to suit a particular function or hydraulic circuit, are made in exactly the same way as conventional valves, taking into account of the flow and pressure of each valve to be used. In some cases, the stacking system may be restricted, so please refer to the following instructions for stacking sequence. Please note, that when designing a system using modular stacking valves, due consideration should be given to working space for future maintenance.

MODEL	INCORRECT	CORRECT	DESCRIPTION
Sol. Oper. Dir. Valve SWG-(*)-3C4 Pilot Operated Check Valve (for "A&B-Lines") MPC-(*)-W Reducing Valve (for "B-Line") MPR-(*)-B			<p>► Stacking sequence when using reducing valves (for "A" or "B" line) and pilot operated check valves) Because reducing valves are spool type, there is an internal leakage. In the stacking sequence shown in the drawing left (incorrect), the cylinder moves due to leakage through the pilot pressure line. Consequently, retaining the position of the cylinder using a pilot operated check valve becomes impossible. The stacking sequence shown in the drawing right (correct) is required in order to retain the cylinder position.</p>
Sol. Oper. Dir. Valve SWG-(*)-3C2 Throttle and Check Valve (for "A&B-Lines", Metre-out) MPC-(*)-W Reducing Valve (for "B-Line") MPR-(*)-B			<p>► Stacking sequence when using reducing valves (for "A" or "B" line) and throttle and check valves (for metre-out). In B to T flow in the drawing left (incorrect), pressure is generated at part with a throttle effect of the throttle and check valve. Depending upon the pressure so generated, the reducing valve may perform a pressure reducing function which causes a shortage of output power of the cylinder and spoils the smooth operation of the cylinder. Therefore, stacking sequence in the drawing right (correct) is required in this combination.</p>
Sol. Oper. Dir. Valve SWG-(*)-3C4 Throttle and Check Valve (for "A&B-Lines", Metre-out) MPC-(*)-W Pilot Operated Check Valve (for "A&B-Lines") MPC-(*)-W			<p>► Stacking sequence when using pilot operated check valves and throttle and check valves (metre-out). In A to T flow in the drawing left (incorrect), pressure is generated at part with a throttle effect of the throttle and check valve. The pressure so generated acts to shut the pilot operated check valve and eventually creates an open and shut operation of the valve repeatedly which may cause the cylinder to have a knocking effect (the same effect will occur in the case of B to T flow). Therefore, the stacking sequence in the drawing right (correct) is required in this combination.</p>



SOLTECH

MODULAR(STACK) CONTROLS

MODULAR RELIEF VALVES & PILOT OPERATED CHECK VALVE-72MPa

RELIEF VALVE [MR-VH]

※SPECIFICATION

MODEL	MAX. OPER. PRES. (Kg f/cm^2)/(MPa)	PRES. ADJ. RANGE (Kg f/cm^2)/(MPa)	MAX. FLOW (ℓ /min)
MR-VH-P	720(72)	0~720(0~72)	8
MR-VH-A			
MR-VH-B			
MR-VH-W			

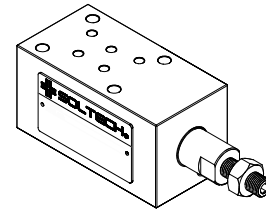

※GRAPHIC SYMBOL

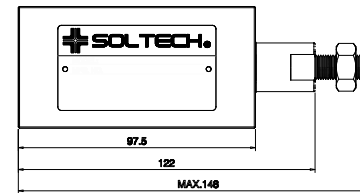
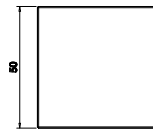
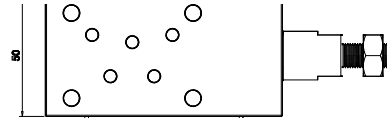
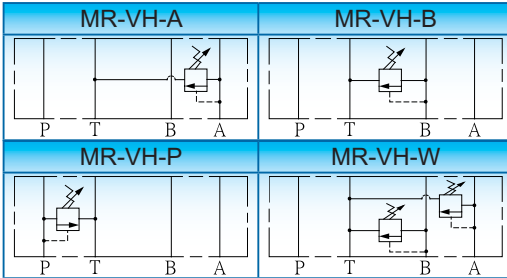

※MODEL NUMBER DESIGNATION

MR	VH	P	(*)	(90)
SERIES NO.	HIGH PRESSURE	FUNCTION PORT P: "P" PORT A: "A" PORT B: "B" PORT W: "A&B" PORT	ADJ. MODEL OMIT: WITH KNOB K: WITHOUT KNOB	OMIT: DIN 912 BOLTS 90: UNC BOLTS (NORTH AMERICA)

PILOT OPERATED CHECK VALVE [MPC-VH]

※SPECIFICATION

MODEL	MAX. OPER. PRES. (Kg f/cm^2)/(MPa)	MAX. FLOW (ℓ /min)
MPC-VH-A	720(72)	8
MPC-VH-B		
MPC-VH-W		

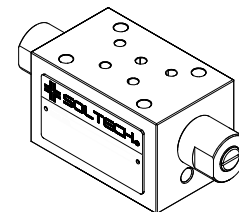

※GRAPHIC SYMBOL

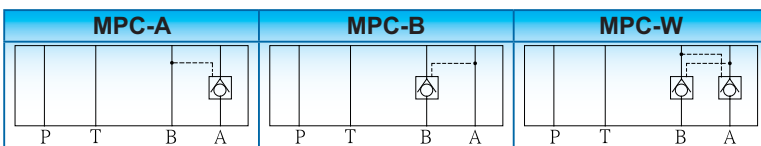

※MODEL NUMBER DESIGNATION

MPC	VH	A	(90)
SERIES NO.	HIGH PRESSURE	FUNCTION PORT A: "A" PORT B: "B" PORT W: "A"&"B" PORT	OMIT: DIN 912 BOLTS 90: UNC BOLTS (NORTH AMERICA)

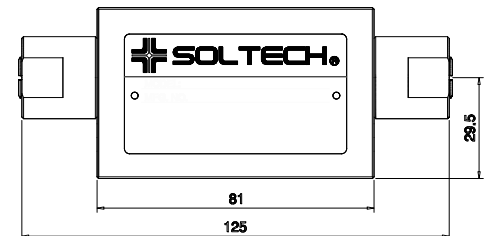
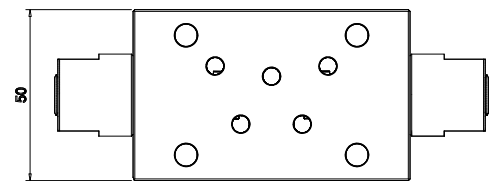
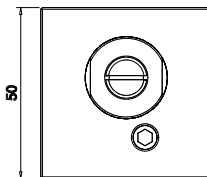

B



SOLTECH

MODULAR(STACK) CONTROLS

MODULAR RELIEF VALVES

【MR-02】

ISO 4401-AB-03-4-A, CETOP 03, NG6, NFPA-D03

※SPECIFICATION

MODEL	MAX. OPER. PRES. (Kgf/cm ²)/(MPa)	MAX. FLOW (ℓ/min)	WEIGHT (Kg)
MR-02-P	210(21)	40	1.7
MR-02-A			
MR-02-B			
MR-02-W			2.6

※GRAPHIC SYMBOL

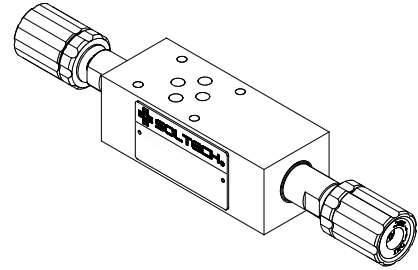
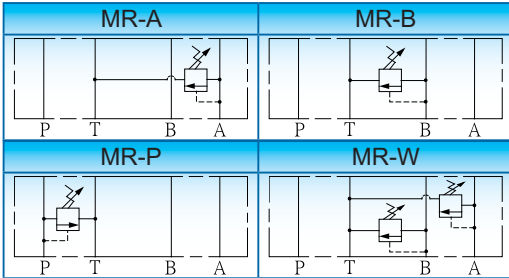

※MODEL NUMBER DESIGNATION

MR	02	P	1	(*)	(90)
SERIES NO.	PORT SIZE 02: NG6	FUNCTION PORT P: "P" PORT A: "A" PORT B: "B" PORT W: "A&B" PORT	PRESSURE ADJ. RANGE (Kgf/cm ²) 1: 8~70 2: 8~140 3: 10~210	ADJ. MODEL OMIT: WITH KNOB K: WITHOUT KNOB	OMIT: DIN 912 BOLTS 90: UNC BOLTS (NORTH AMERICA)

※DIMENSIONS

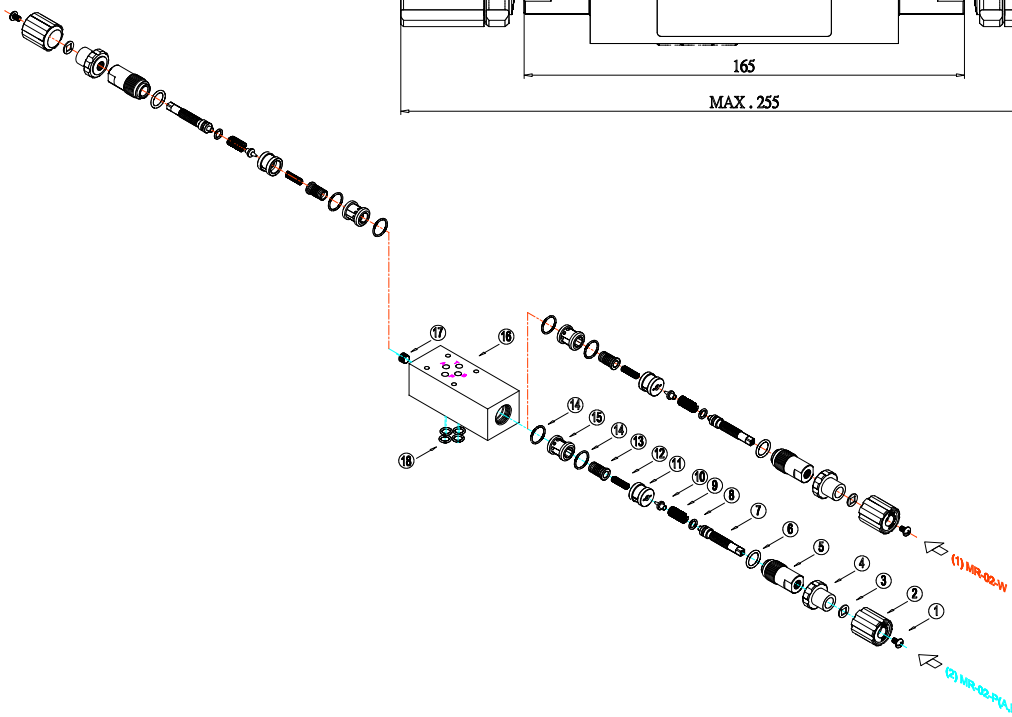
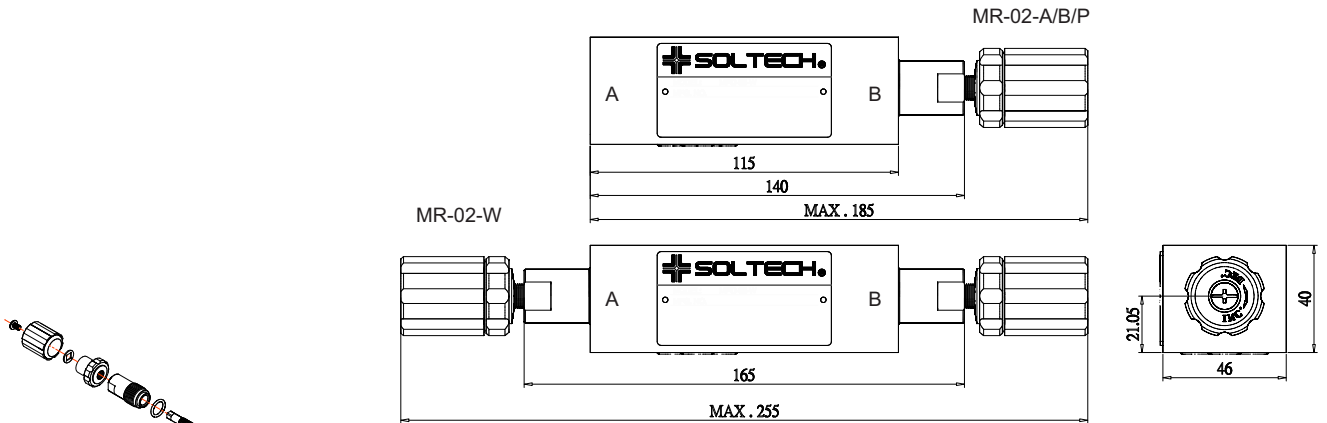

Item No.	Part No.	Quantity(PCs)	
		(A/B/P)	(W)
1	SB00006	1	2
2	P000009	1	2
3	P000010	1	2
4	IR00037	1	2
5	OR0001	1	2
6	IR00038	1	2
7	OR00023	1	2
8	S000013	1	2
9	IR00039	1	2
10	IR00044	1	2
11	S000016	1	2
12	SP00063	1	2
13	OR00012	2	4
14	SP00064	1	2
15	FB00012	1	1
16	SB00005	1	1
17	OR00003	4	4



SOLTECH

MODULAR(STACK) CONTROLS

MODULAR PRESSURE RELIEF VALVES

【MR-03】

ISO 4401-AC-05-4-A, CETOP 05, NG10, NFPA-D05

※SPECIFICATION

MODEL	MAX. OPER. PRES. (Kgf/cm ²)/(MPa)	MAX. FLOW (ℓ/min)	WEIGHT (Kg)
MR-03-P	210(21)	80	3.7
MR-03-A			
MR-03-B			
MR-03-W			4.4

※GRAPHIC SYMBOL

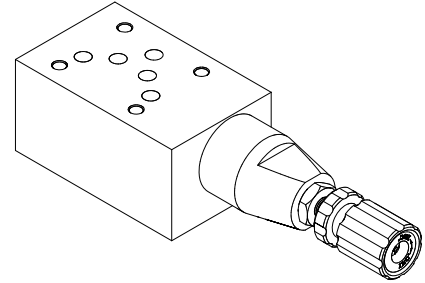
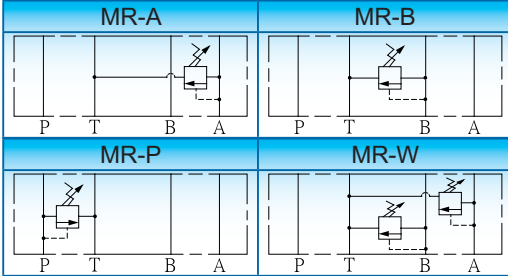

※MODEL NUMBER DESIGNATION

MR	03	P	1	(*)	(90)
SERIES NO.	PORT SIZE 03: NG10	FUNCTION PORT P: "P" PORT A: "A" PORT B: "B" PORT w: "A&B" PORT	PRESSURE ADJ. RANGE (Kgf/cm ²) 1: 8~70 2: 8~140 3: 10~210	ADJ. MODEL OMIT: WITH KNOB K: WITHOUT KNOB	OMIT: DIN 912 BOLTS 90: UNC BOLTS (NORTH AMERICA)

※DIMENSIONS

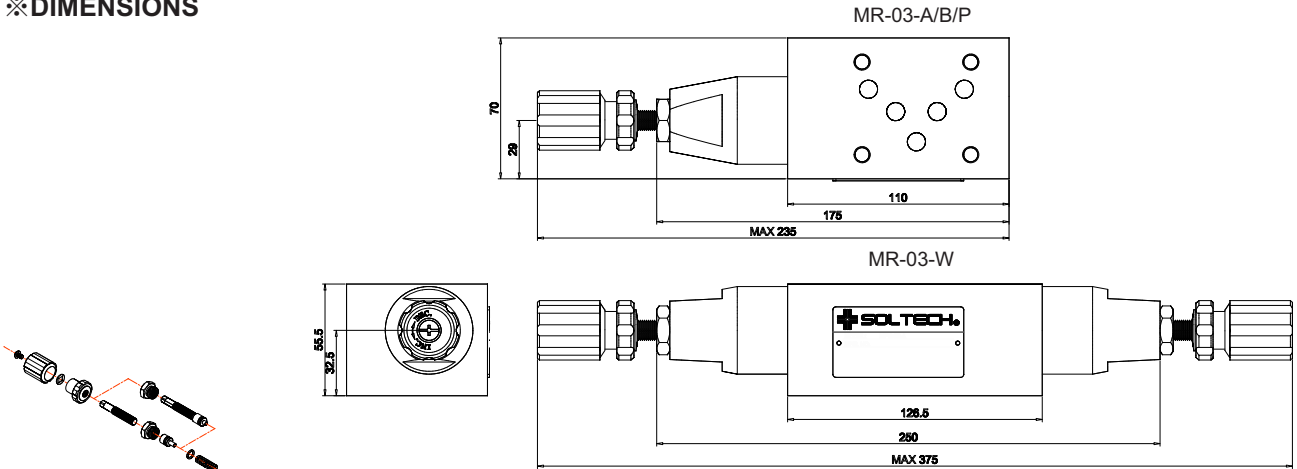

Item No.	Part No.	Quantity(PCs)	
		(A/B/P)	(W)
1	IR00033	2	1
2	IR00063	2	1
3	IR00032	2	1
4	IR00030	2	1
5	OR00011	2	1
6	S000010	2	1
7	IR00035	2	1
8	FB00018	2	1
9	OR00024	4	2
10	OR00010	2	1
11	S000017	2	1
12	SP00065	2	1
13	SP00066	2	1
14	FB00012	2	1
15	OR00004	5	5

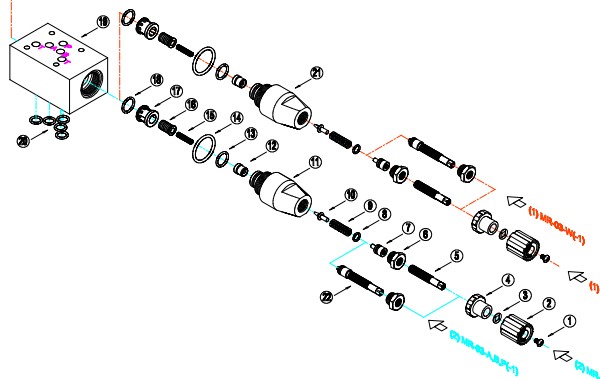

B



SOLTECH

MODULAR(STACK) CONTROLS

MODULAR PRESSURE REDUCING VALVES

【MPR-02】

ISO 4401-AB-03-4-A, CETOP 03, NG6, NFPA-D03

※SPECIFICATION

MODEL	MAX. OPER. PRES. (Kgf/cm ²)/(MPa)	MAX. FLOW (ℓ/min)	WEIGHT (Kg)
MPR-02-P	210(21)	40	1.4
MPR-02-A			
MPR-02-B			

※GRAPHIC SYMBOL

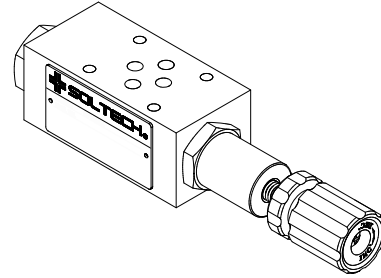
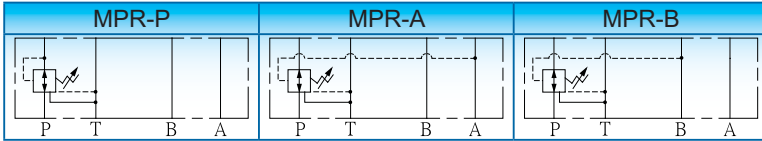

※MODEL NUMBER DESIGNATION

MPR	02	P	1	(*)	(90)
SERIES NO.	PORT SIZE 02: NG6	FUNCTION PORT P: "P" PORT A: "A" PORT B: "B" PORT	PRESSURE ADJ. RANGE (Kgf/cm ²) 1: 8~35 2: 8~70 3: 35~210	ADJ. MODEL OMIT: WITH KNOB K: WITHOUT KNOB	OMIT: DIN 912 BOLTS 90: UNC BOLTS (NORTH AMERICA)

※DIMENSIONS

The handle is at "A" side, When it's MPR-02-A/P

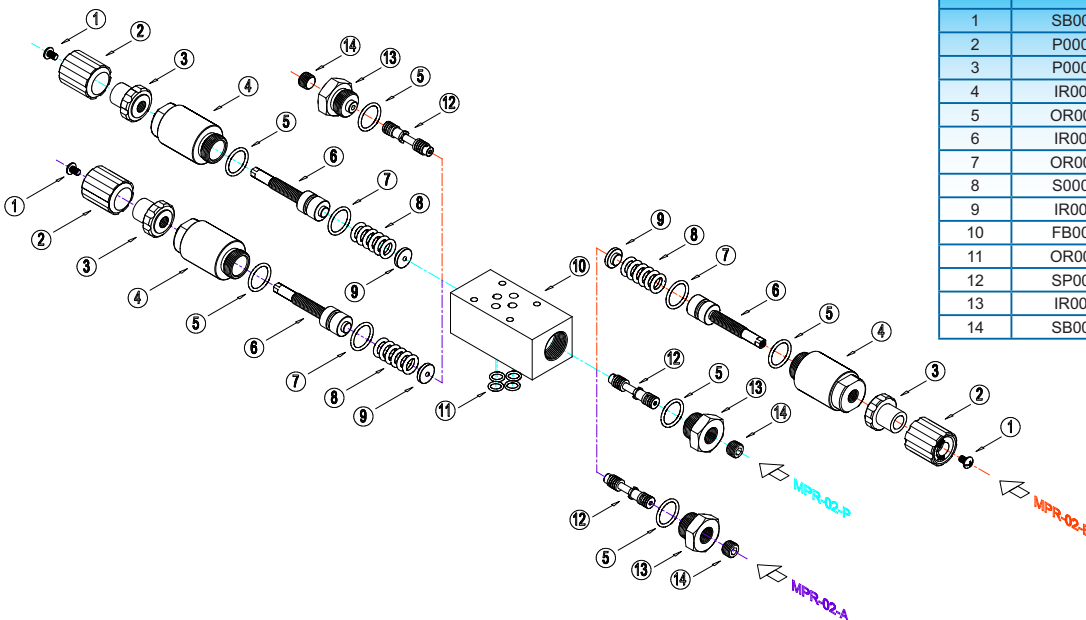
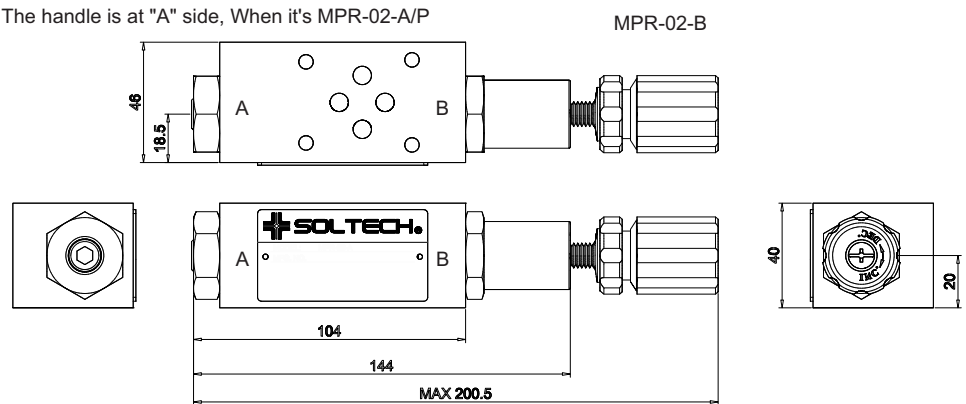

Item No.	Part No.	Quantity(PCs) (A/B/P)
1	SB00006	1
2	P000009	1
3	P000010	1
4	IR00026	1
5	OR00009	2
6	IR00027	1
7	OR00008	1
8	S000006	1
9	IR00029	1
10	FB00009	1
11	OR00003	4
12	SP00061	1
13	IR00028	1
14	SB00005	1



SOLTECH

MODULAR(STACK) CONTROLS

MODULAR PRESSURE REDUCING VALVES

【MPR-03】

ISO 4401-AC-05-4-A, CETOP 05, NG10, NFPA-D05

※SPECIFICATION

MODEL	MAX. OPER. PRES. (Kgf/cm ²)/(MPa)	MAX. FLOW (ℓ/min)	WEIGHT (Kg)
MPR-03-P	210(21)	80	3.6
MPR-03-A			
MPR-03-B			

※GRAPHIC SYMBOL

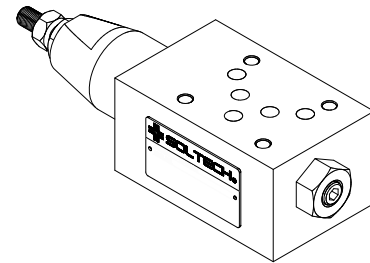
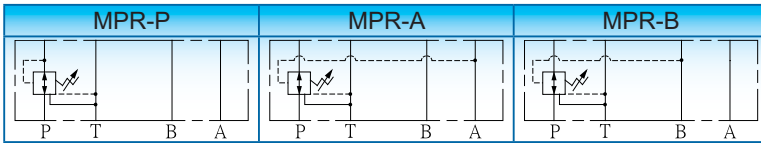

※MODEL NO. DESIGNATION

MPR	03	P	1	(*)	(90)
SERIES NO.	PORT SIZE 02: NG10	FUNCTION PORT P: "P" PORT A: "A" PORT B: "B" PORT	PRESSURE ADJ. RANGE (Kgf/cm ²) 1: 8~35 2: 8~70 3: 10~210	ADJ. MODEL OMIT: WITH KNOB K: WITHOUT KNOB	OMIT: DIN 912 BOLTS 90: UNC BOLTS (NORTH AMERICA)

※DIMENSIONS

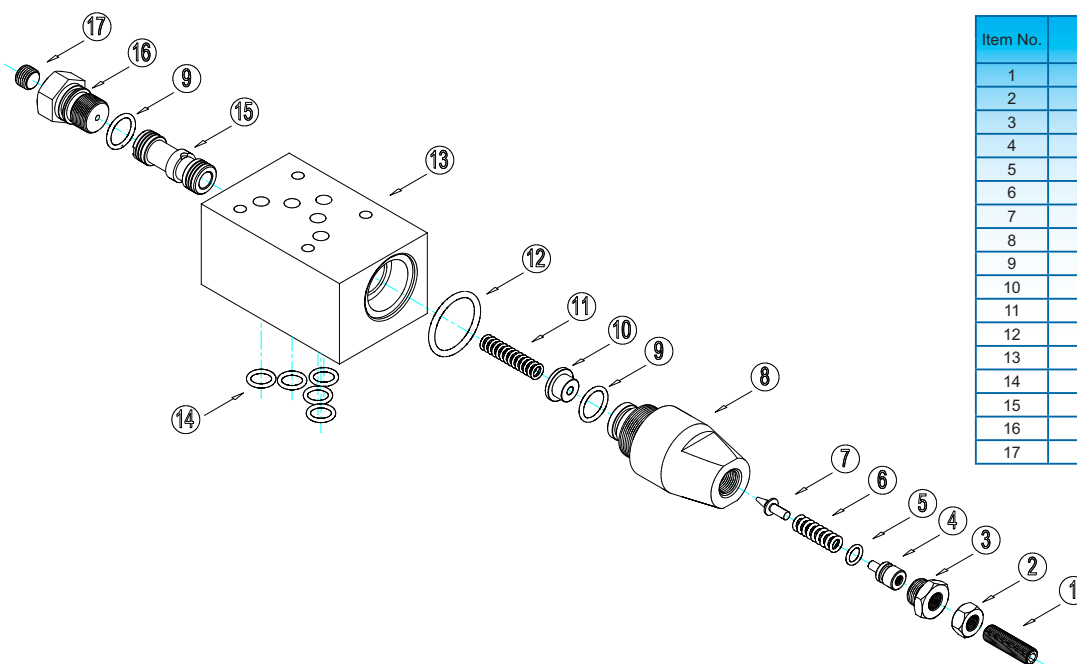
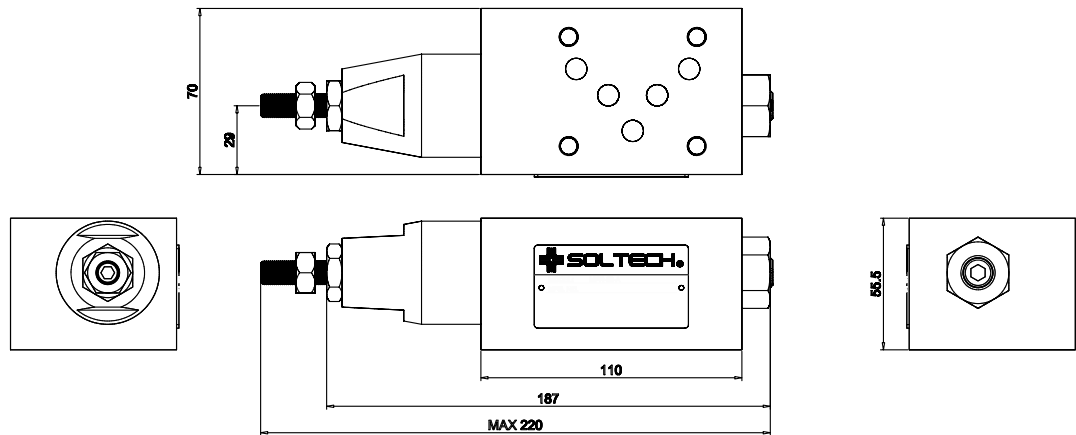

Item No.	Part No.	Quantity(PCs)
		(A/B/P)
1	SB00011	1
2	N000001	1
3	IR00063	1
4	IR00030	1
5	OR00011	1
6	S000010	1
7	IR00035	1
8	IR00036	1
9	OR00011	2
10	IR00031	1
11	S000011	1
12	OR00010	1
13	FB00008	1
14	OR00004	5
15	SP00062	1
16	IR00034	1
17	SB00005	1

B



SOLTECH

MODULAR(STACK) CONTROLS

MODULAR THROTTLE AND CHECK VALVES

【MTC-02】

ISO 4401-AB-03-4-A, CETOP 03, NG6, NFPA-D03

※SPECIFICATION

MODEL	MAX. OPER. PRES. (Kgf/cm ²)/(MPa)	MAX. FLOW (ℓ/min)	WEIGHT (Kg)
MTC-02-A	210(21)	40	1.4
MTC-02-B			
MTC-02-W			1.5

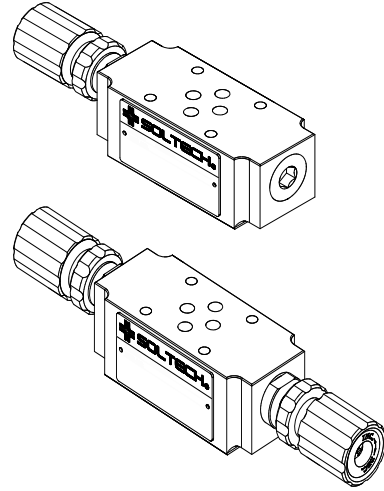

※GRAPHIC SYMBOL

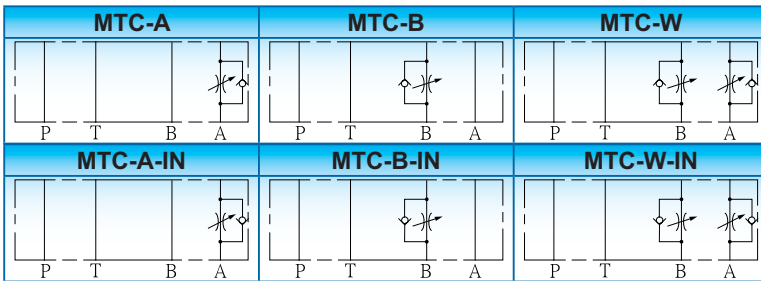

※MODEL NUMBER DESIGNATION

MTC	02	P	IN	(*)	(90)
SERIES NO.	PORT SIZE 02: NG6	FUNCTION PORT A: "A" PORT B: "B" PORT W: "A"&"B" PORTS	ORIENTATION OMIT: METER OUT IN: METER IN	ADJ. MODEL OMIT: WITH KNOB N: WITHOUT KNOB	OMIT: DIN 912 BOLTS 90: UNC BOLTS (NORTH AMERICA)

※DIMENSIONS

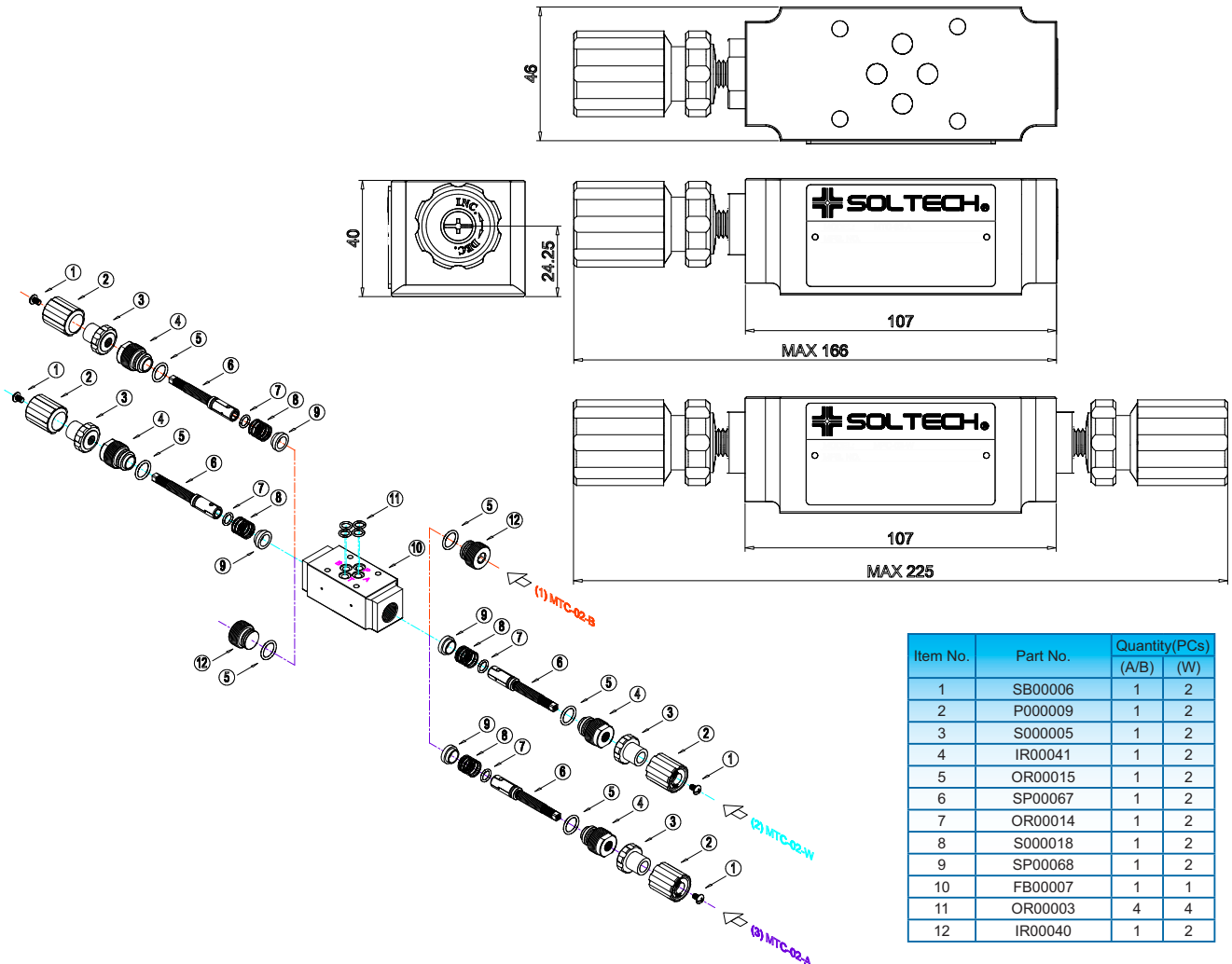

Item No.	Part No.	Quantity(PCs)	
		(A/B)	(W)
1	SB00006	1	2
2	P000009	1	2
3	S000005	1	2
4	IR00041	1	2
5	OR00015	1	2
6	SP00067	1	2
7	OR00014	1	2
8	S000018	1	2
9	SP00068	1	2
10	FB00007	1	1
11	OR00003	4	4
12	IR00040	1	2

B



SOLTECH

MODULAR(STACK) CONTROLS

MODULAR THROTTLE AND CHECK VALVES

【MTC-03】

ISO 4401-AC-05-4-A, CETOP 05, NG10, NFPA-D05

※SPECIFICATION

MODEL	MAX. OPER. PRES. (Kgf/cm ²)/(MPa)	MAX. FLOW (ℓ/min)	WEIGHT (Kg)
MTC-03-A	210(21)	80	2.5
MTC-03-B			
MTC-03-W			3.1

※GRAPHIC SYMBOL

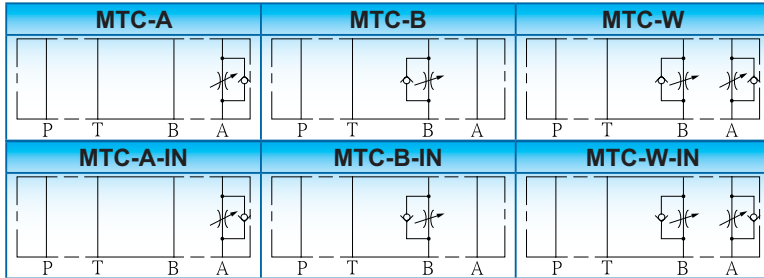

※MODEL NUMBER DESIGNATION

MTC	03	A	IN	(*)	(90)
SERIES NO.	PORT SIZE 03: NG10	FUNCTION PORT A: "A" PORT B: "B" PORT W: "A"&"B" PORTS	ORIENTATION OMIT: METER OUT IN: METER IN	ADJ. MODEL OMIT: WITH KNOB N: WITHOUT KNOB	OMIT: DIN 912 BOLTS 90: UNC BOLTS (NORTH AMERICA)

※DIMENSIONS

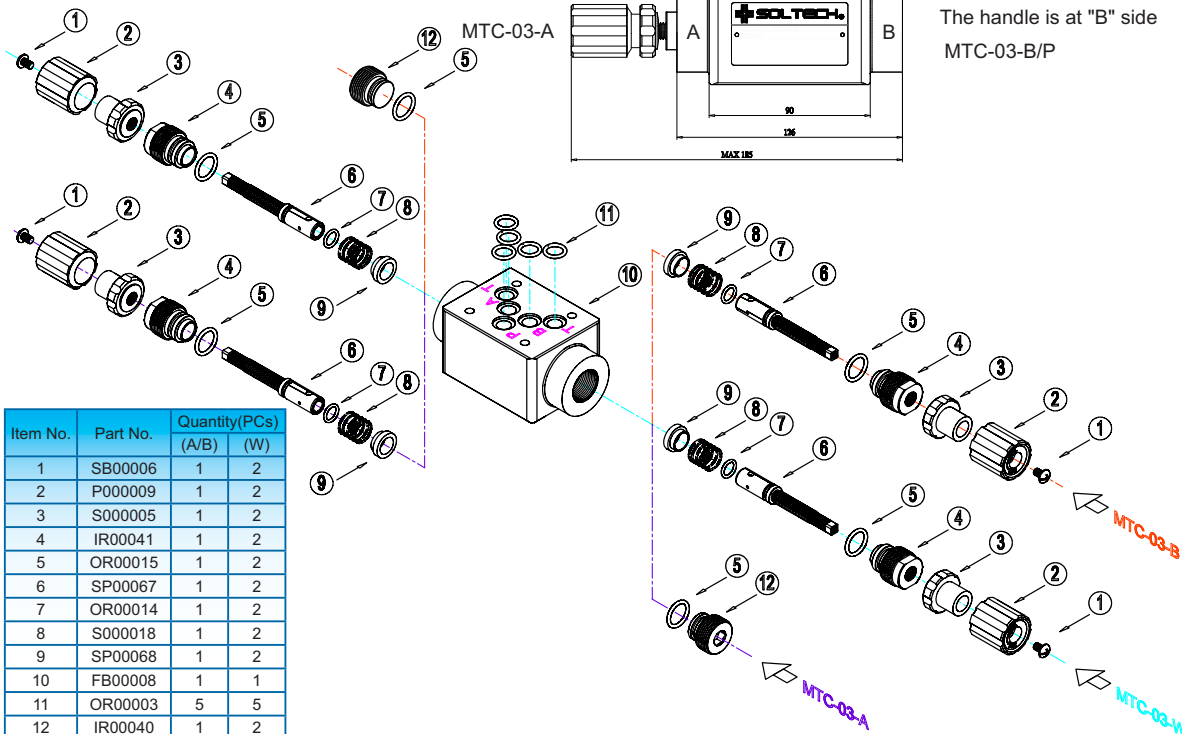
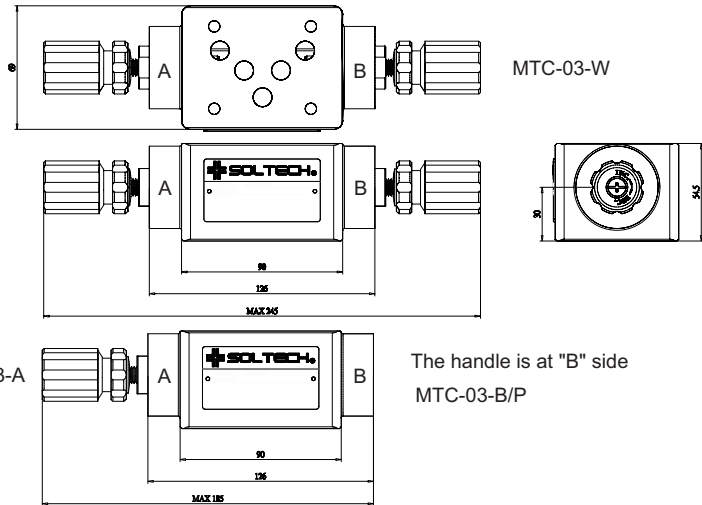

Item No.	Part No.	Quantity(PCs)	
		(A/B)	(W)
1	SB00006	1	2
2	P000009	1	2
3	S000005	1	2
4	IR00041	1	2
5	OR00015	1	2
6	SP00067	1	2
7	OR00014	1	2
8	S000018	1	2
9	SP00068	1	2
10	FB00008	1	1
11	OR00003	5	5
12	IR00040	1	2

B



SOLTECH

MODULAR(STACK) CONTROLS

MODULAR COUNTER-BALANCE VALVES

【MSCV-02】

ISO 4401-AB-03-4-A, CETOP 03, NG6, NFPA-D03

※SPECIFICATION

MODEL	MAX. OPER. PRES. (Kgf/cm ²)/(MPa)	MAX. FLOW (ℓ/min)	WEIGHT (Kg)
MSCV-02-A	210(21)	40	1.5
MSCV-02-B			

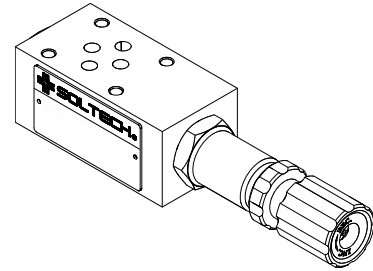

※GRAPHIC SYMBOL

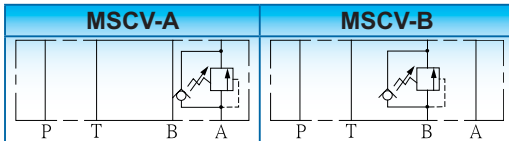

※MODEL NUMBER DESIGNATION

MSCV	02	A	1	(*)	(90)
SERIES NO.	PORT SIZE 02: NG6	FUNCTION PORT A: "A" PORT B: "B" PORT	PRESSURE ADJ. RANGE (Kgf/cm ²) 1: 7~70 2: 10~210	ADJ. MODEL OMIT: WITH KNOB N: WITHOUT KNOB	OMIT: DIN 912 BOLTS 90: UNC BOLTS (NORTH AMERICA)

※DIMENSIONS

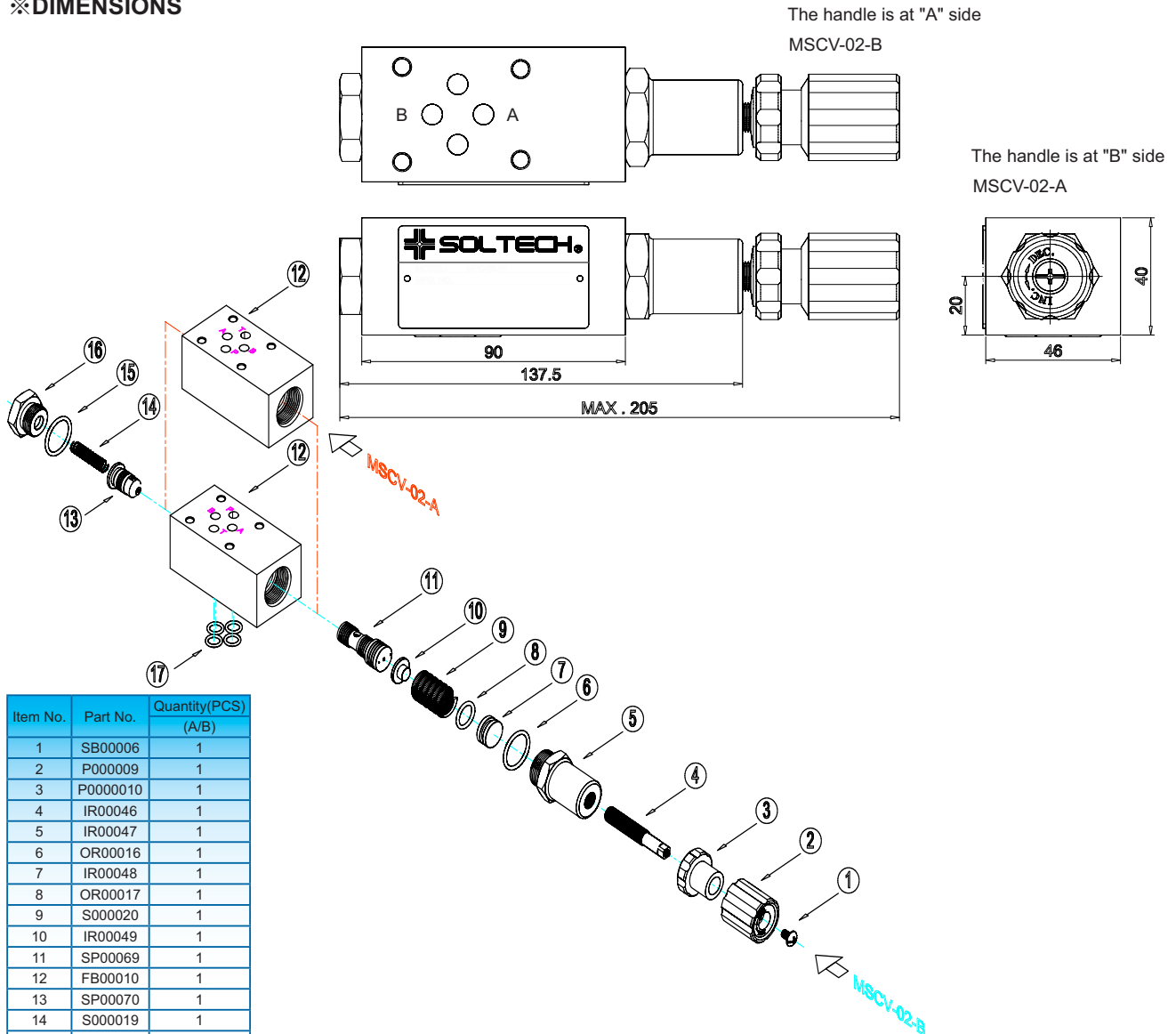

Item No.	Part No.	Quantity(PCS) (A/B)
1	SB00006	1
2	P000009	1
3	P000010	1
4	IR00046	1
5	IR00047	1
6	OR00016	1
7	IR00048	1
8	OR00017	1
9	S000020	1
10	IR00049	1
11	SP00069	1
12	FB00010	1
13	SP00070	1
14	S000019	1
15	OR00013	1
16	IR00045	1
17	OR00006	4



SOLTECH

MODULAR(STACK) CONTROLS

MODULAR COUNTER-BALANCE VALVES

【MSCV-03】

ISO 4401-AC-05-4-A, CETOP 05, NG10, NFPA-D05

※SPECIFICATION

MODEL	MAX. OPER. PRES. (Kgf/cm ²)/(MPa)	MAX. FLOW (ℓ/min)	WEIGHT (Kg)
MSCV-03-A	210(21)	80	4.5
MSCV-03-B			

※GRAPHIC SYMBOL

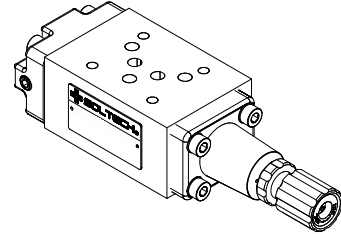
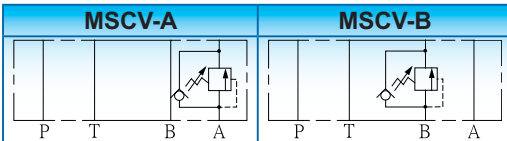

B

※MODEL NUMBER DESIGNATION

MSCV	03	A	1	(*)	(90)
SERIES NO.	PORT SIZE 03: NG10	FUNCTION PORT A: "A" PORT B: "B" PORT	PRESSURE ADJ. RANGE (Kgf/cm ²) 1: 7~70 2: 10~210	ADJ. MODEL OMIT: WITH KNOB N: WITHOUT KNOB	OMIT: DIN 912 BOLTS 90: UNC BOLTS (NORTH AMERICA)

※DIMENSIONS

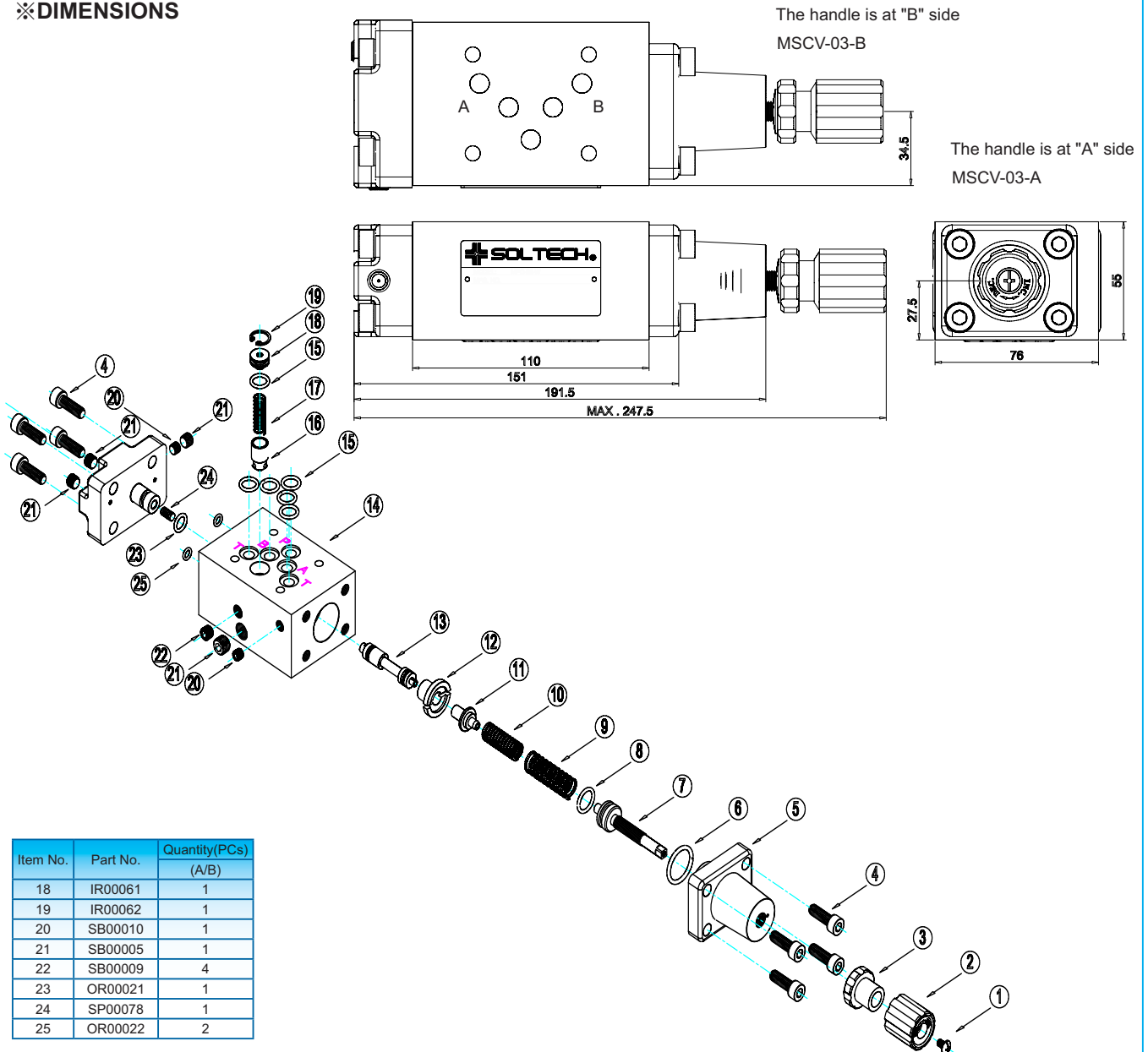

Item No.	Part No.	Quantity(PCs) (A/B)
18	IR00061	1
19	IR00062	1
20	SB00010	1
21	SB00005	1
22	SB00009	4
23	OR00021	1
24	SP00078	1
25	OR00022	2



SOLTECH

MODULAR(STACK) CONTROLS

MODULAR CHECK VALVES

【MC-02】

ISO 4401-AB-03-4-A, CETOP 03, NG6, NFPA-D03

※SPECIFICATION

MODEL	MAX. OPER. PRES. (Kgf/cm ²)/(MPa)	MAX. FLOW (ℓ/min)	WEIGHT (Kg)
MC-02-P	210(21)	40	1.2
MC-02-T			
MC-02-A/B			
MC-02-W			

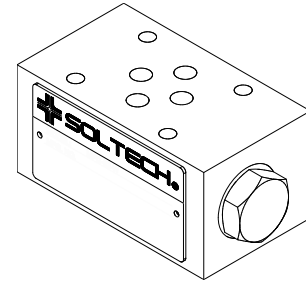

※GRAPHIC SYMBOL

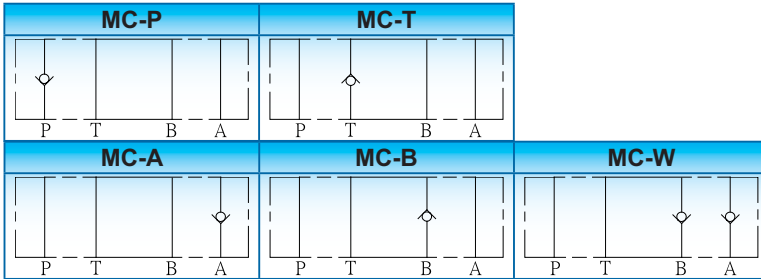

※MODEL NUMBER DESIGNATION

MC	02	A	1	(90)
SERIES NO.	PORT SIZE 02: NG6	FUNCTION PORT A: "A" PORT B: "B" PORT W: "A"&"B" PORT P: "P" PORT T: "T" PORT	CRACKING PRESSURE (Kg/cm ²) 1: 0.5 2: 2.5 3: 4	OMIT: DIN 912 BOLTS 90: UNC BOLTS (NORTH AMERICA)

※DIMENSIONS

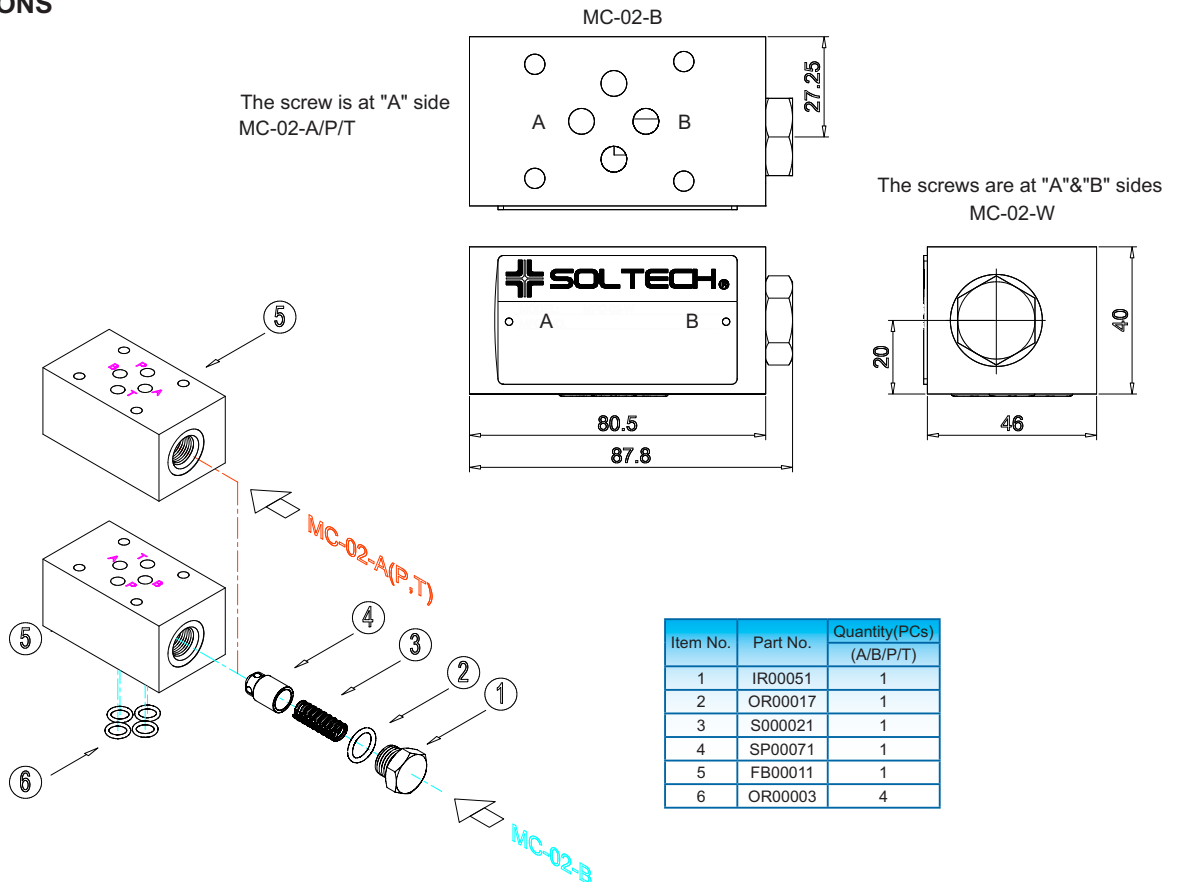

B



SOLTECH

MODULAR(STACK) CONTROLS

MODULAR CHECK VALVES

【MC-03】

ISO 4401-AC-05-4-A, CETOP 05, NG10, NFPA-D05

※SPECIFICATION

MODEL	MAX. OPER. PRES. (Kgf/cm ²)/(MPa)	MAX. FLOW (ℓ/min)	WEIGHT (Kg)
MC-03-P	210(21)	80	2.7
MC-03-T			
MC-03-A/B			
MC-03-W			

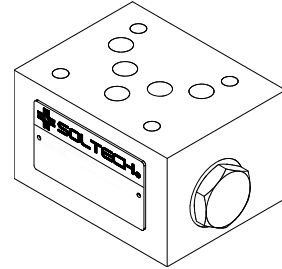

※GRAPHIC SYMBOL

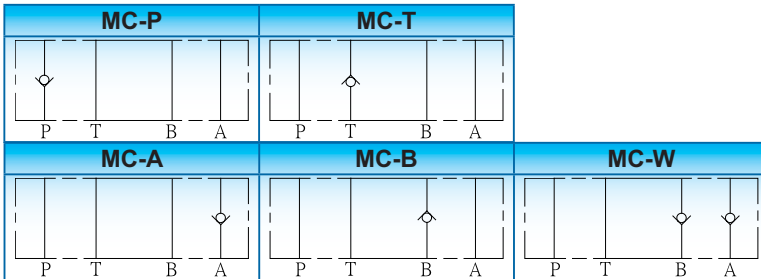

※MODEL NUMBER DESIGNATION

MC	03	A	1	(90)
SERIES NO.	PORT SIZE 03: NG10	FUNCTION PORT A: "A" PORT B: "B" PORT W: "A"&"B" PORT P: "P" PORT T: "T" PORT	CRACKING PRESSURE (Kg/cm ²) 1: 0.5 2: 2.5 3: 4	OMIT: DIN 912 BOLTS 90: UNC BOLTS (NORTH AMERICA)

※DIMENSIONS

The screw is at "B" side

MC-03-B

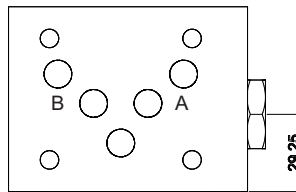

MC-03-A/P/T

The screws are at "A"&"B" sides
MC-03-W

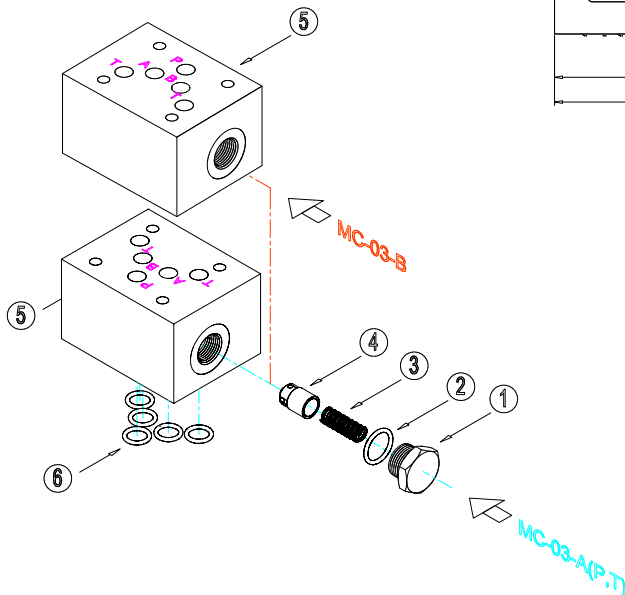
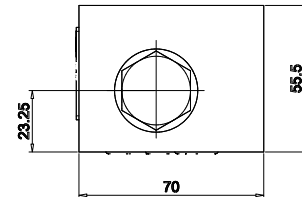
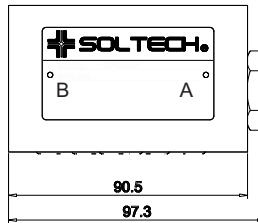

Item No.	Part No.	Quantity(Ps) (A/B/P/T)
1	FB00014	1
2	OR00013	1
3	S000021	1
4	SP00074	1
5	FB00014	1
6	OR00004	5



SOLTECH

MODULAR(STACK) CONTROLS

MODULAR PILOT OPERATED CHECK VALVES

【MPC-02】

ISO 4401-AB-03-4-A, CETOP 03, NG6, NFPA-D03

※SPECIFICATION

MODEL	MAX. OPER. PRES. (Kg/cm ²)/(MPa)	MAX. FLOW (ℓ/min)	WEIGHT (Kg)
MPC-02-A	210(21)	40	1.4
MPC-02-B			
MPC-02-W			

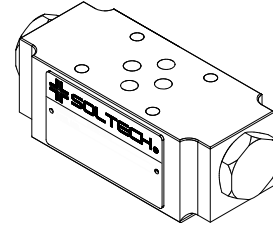

※GRAPHIC SYMBOL

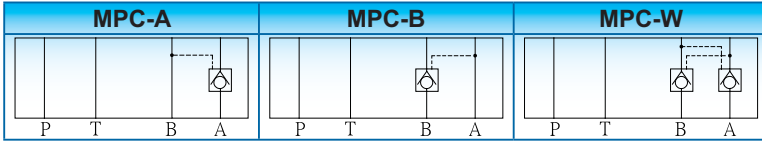

※MODEL NUMBER DESIGNATION

MPC	02	A	(90)
SERIES NO.	PORT SIZE 02: NG6	FUNCTION PORT A: "A" PORT B: "B" PORT W: "A"&"B" PORT	OMIT: DIN 912 BOLTS 90: UNC BOLTS (NORTH AMERICA)

※DIMENSIONS

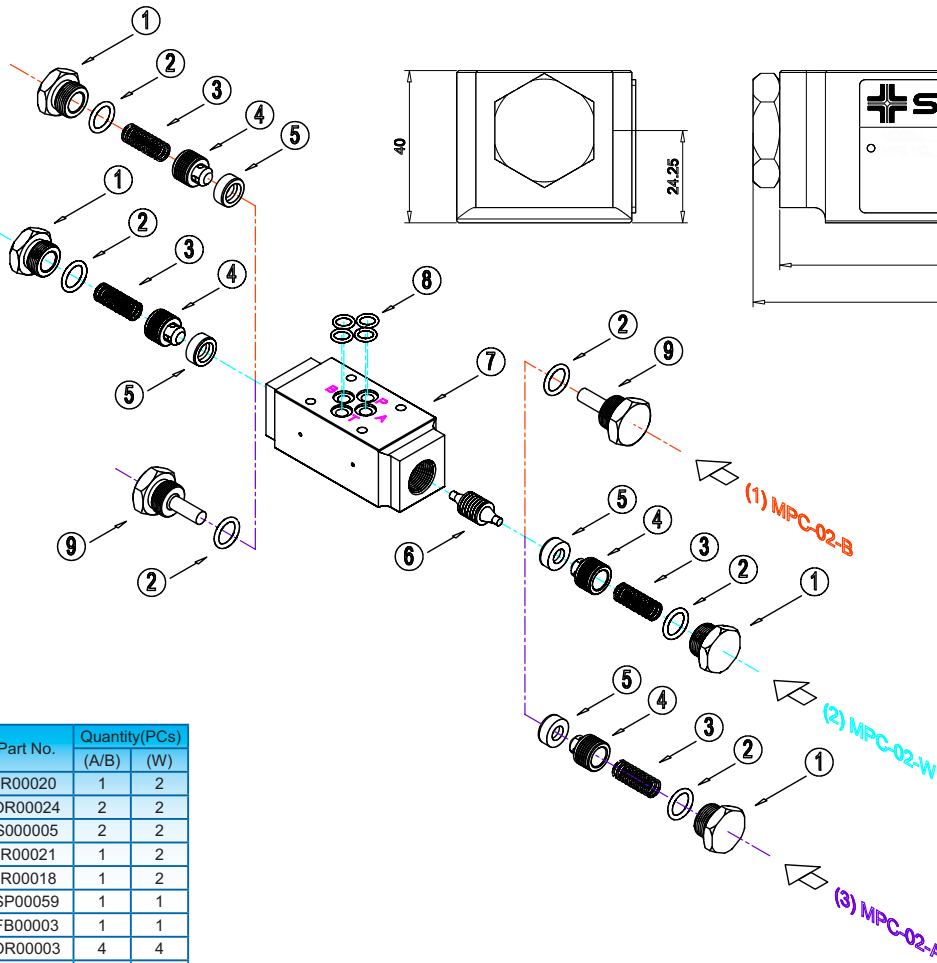
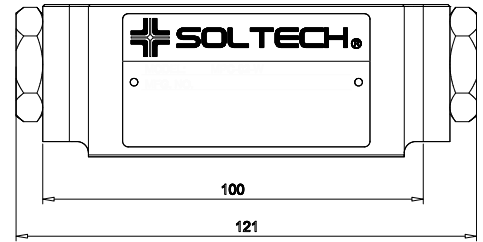
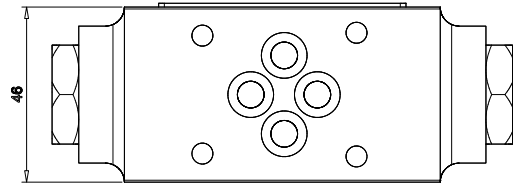

Item No.	Part No.	Quantity(PCs)	
		(A/B)	(W)
1	IR00020	1	2
2	OR00024	2	2
3	S000005	2	2
4	IR00021	1	2
5	IR00018	1	2
6	SP00059	1	1
7	FB00003	1	1
8	OR00003	4	4
9	IR00019	1	0



SOLTECH

MODULAR(STACK) CONTROLS

MODULAR PILOT OPERATED CHECK VALVES

【MPC-03】

ISO 4401-AC-05-4-A, CETOP 05, NG10, NFPA-D05

※SPECIFICATION

MODEL	MAX. OPER. PRES. (Kg/cm ²)/(MPa)	MAX. FLOW (ℓ/min)	WEIGHT (Kg)
MPC-03-A	210(21)	80	2.7
MPC-03-B			
MPC-03-W			

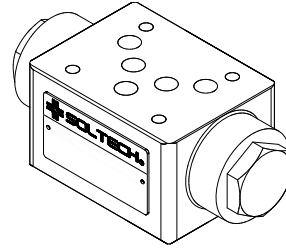

※GRAPHIC SYMBOL

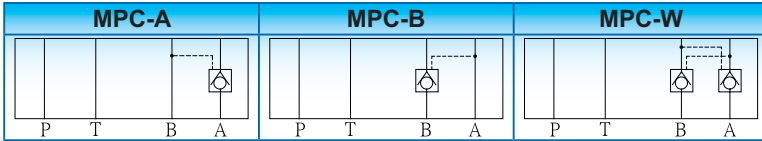

※MODEL NUMBER DESIGNATION

MPC	03	A	(90)
SERIES NO.	PORT SIZE 03: NG10	FUNCTION PORT A: "A" PORT B: "B" PORT W: "A"&"B" PORT	OMIT: DIN 912 BOLTS 90: UNC BOLTS (NORTH AMERICA)

※DIMENSIONS

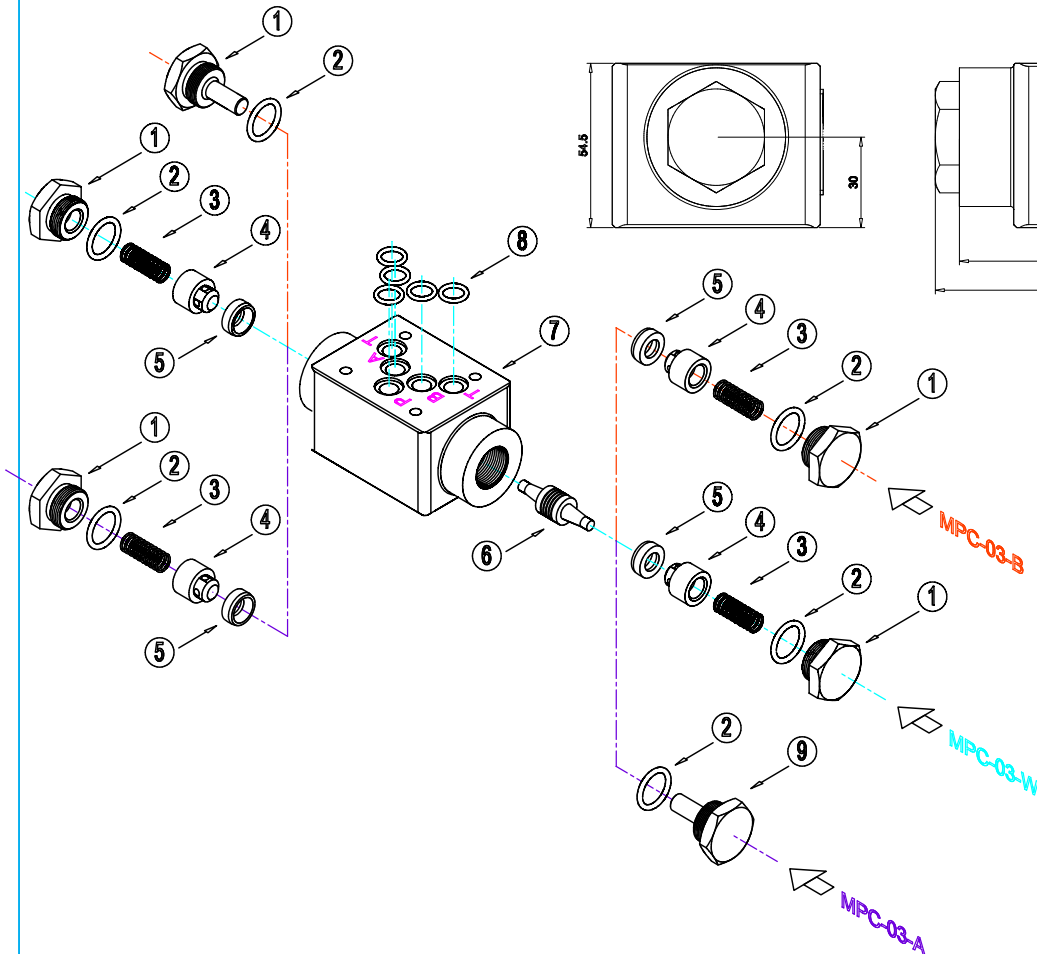
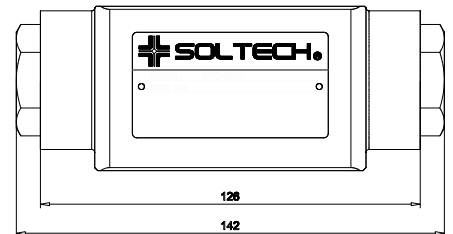
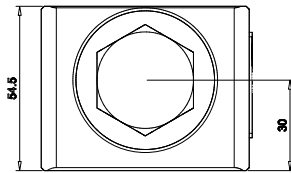
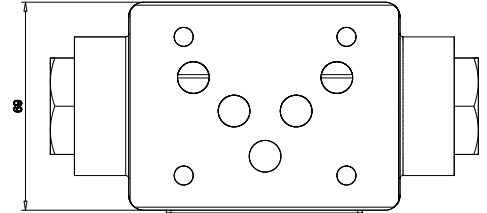

Item No.	Part No.	Quantity(PCs)	
		(A/B)	(W)
1	IR00022	1	2
2	OR00006	2	2
3	S000005	2	2
4	IR00025	1	2
5	IR00023	1	2
6	SP00060	1	1
7	FB00004	1	1
8	OR00004	4	4
9	IR00024	1	0

B



SOLTECH

MODULAR(STACK) CONTROLS

HYDRAULIC COVER PLATE

B

【MDC-02】

ISO 4401-AB-03-4-A, CETOP 03, NG6, NFPA-D03

※MODEL NUMBER DESIGNATION

MDC	02	PT
SERIES NO.	PORT SIZE 02: NG6	COMMUNICATION OF PORTS OMIT: ALL BLOCK PT: P TO T PA: P TO A PB: P TO B PABT: P TO A, B TO T



※GRAPHIC SYMBOL

MDC	MDC-PT	
MDC-PA	MDC-PB	MDC-PABT

※DIMENSIONS

MDC-02-OMIT

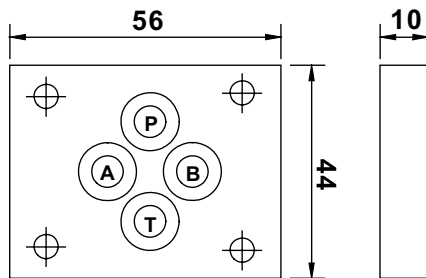

MDC-02-(※)

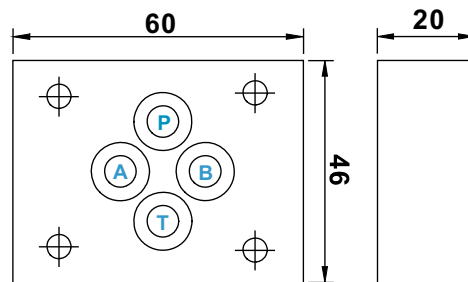

※MODEL NUMBER DESIGNATION

MDC	03	PT
SERIES NO.	PORT SIZE 03: NG10	COMMUNICATION OF PORTS OMIT: ALL BLOCK PT: P TO T PA: P TO A PB: P TO B PABT: P TO A, B TO T

【MDC-03】

ISO 4401-AC-05-4-A, CETOP 05, NG10, NFPA-D05

※GRAPHIC SYMBOL

MDC	MDC-PT	
MDC-PA	MDC-PB	MDC-PABT



※DIMENSIONS

MDC-03-OMIT

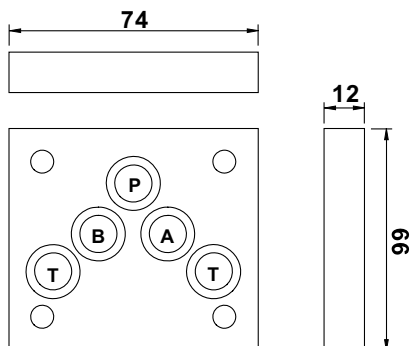

MDC-03-(※)

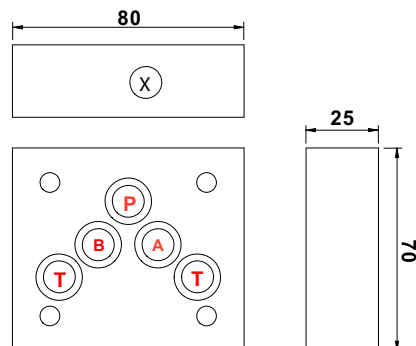



MODULAR(STACK) CONTROLS

STANDARD MANIFOLD

SOLTECH

【MMC-02】

ISO 4401-AB-03-4-A, CETOP 03, NG6, NFPA-D03

※MODEL NUMBER DESIGNATION

MMC	02	001	D
SERIES NO.	PORT SIZE 02: NG6	NO. OF VALVES 1, 2, 3, 4, 5	D: DIN 912 BOLTS U: UNC BOLTS

※GRAPHIC SYMBOL

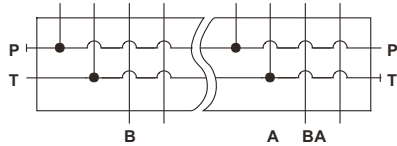

※DIMENSIONS

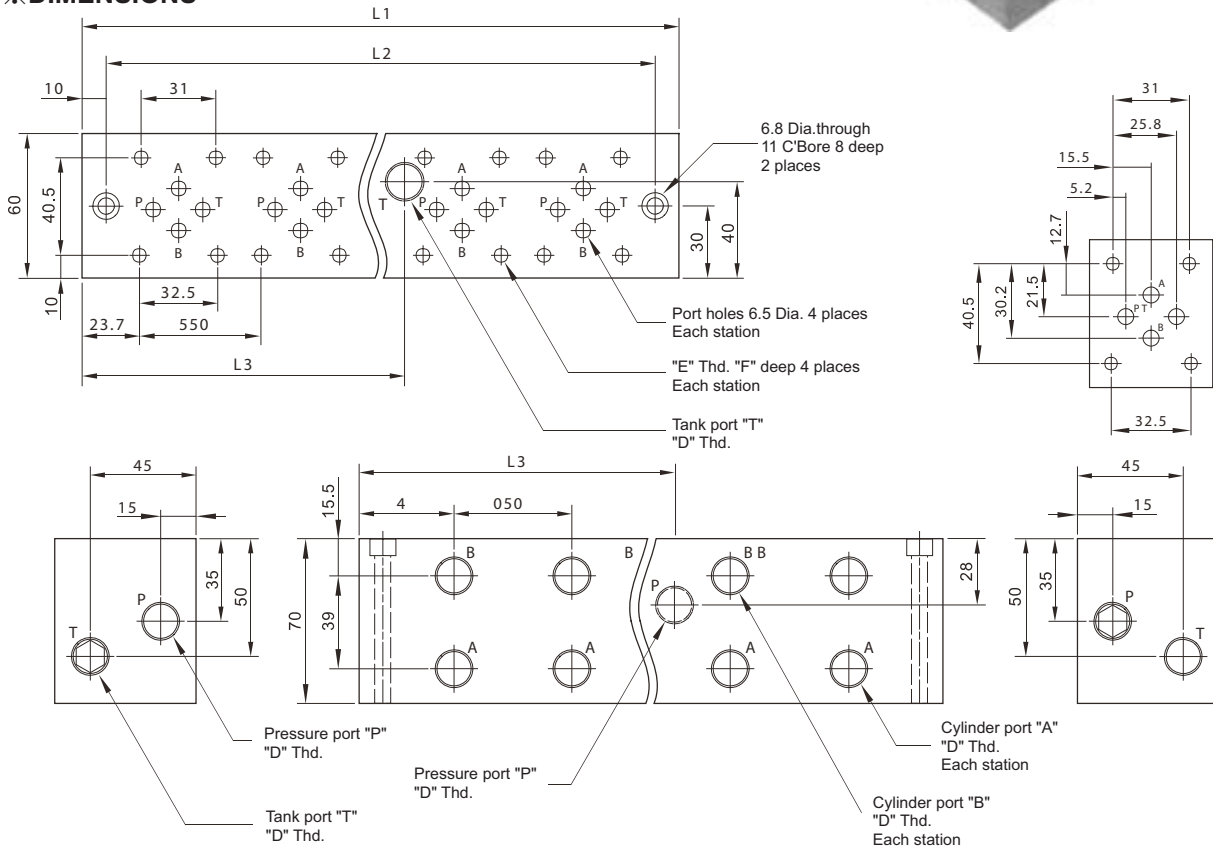

Model numbers		Piping size	"E" Thd.	Dimensions (mm)			Lengths	Weight (kg)
		"D" Thd.		F	L1	L2		
MMC-02-002	D	Rc 3/8	M5	10	130	110	65	3.65
	U	3/8 NPT	No. 10-24 UNC	12				
MMC-02-003	D	Rc 3/8	M5	10	180	16	65	5.0
	U	3/8 NPT	No. 10-24 UNC	12				
MMC-02-004	D	Rc 3/8	M5	10	230	210	115	7.7
	U	3/8 NPT	No. 10-24 UNC	12				
MMC-02-005	D	Rc 3/8	M5	10	280	260	115	7.7
	U	3/8 NPT	No. 10-24 UNC	12				
MMC-02-006	D	Rc 3/8	M5	10	330	310	165	9.3
	U	3/8 NPT	No. 10-24 UNC	12				
MMC-02-007	D	Rc 3/8	M5	10	380	360	165	10.6
	U	3/8 NPT	No. 10-24 UNC	12				
MMC-02-008	D	Rc 3/8	M5	10	430	10	215	12.1
	U	3/8 NPT	No. 10-24 UNC	12				
MMC-02-009	D	Rc 3/8	M5	10	480	460	215	13.5
	U	3/8 NPT	No. 10-24 UNC	12				
MMC-02-010	D	Rc 3/8	M5	10	530	510	265	N/A
	U	3/8 NPT	No. 10-24 UNC	12				

B



SOLTECH

MODULAR(STACK) CONTROLS

STANDARD MANIFOLD

【MMC-03】

ISO 4401-AC-05-4-A, CETOP 05, NG10, NFPA-D05

※MODEL NUMBER DESIGNATION

MMC	03	001	D
SERIES NO.	PORT SIZE 02: NG10	NO. OF VALVES 1, 2, 3, 4, 5	D: DIN 912 BOLTS U: UNC BOLTS



※GRAPHIC SYMBOL

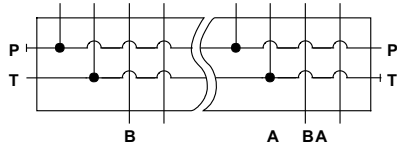

※DIMENSIONS

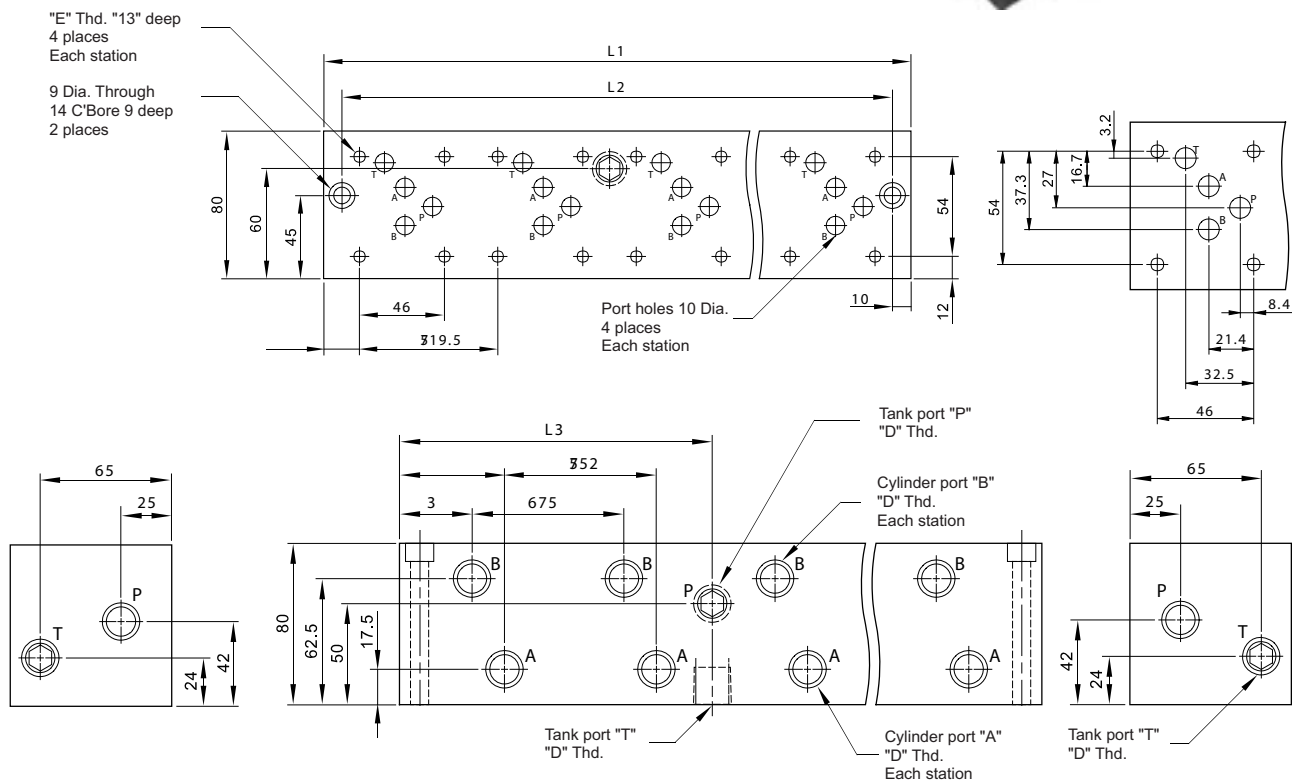

Model numbers		Piping size		Lengths			Weight (kg)
		"D" Thd.	"E" Thd.	L1	L2	L3	
MMC-03-002	D	Rc 1/2	M6	160	140	80	6.9
	U	1/2 NPT	1/4-20 UNC				
MMC-03-003	D	Rc 1/2	M6	235	215	80	10.2
	U	1/2 NPT	1/4-20 UNC				
MMC-03-004	D	Rc 1/2	M6	310	290	155	13.5
	U	1/2 NPT	1/4-20 UNC				
MMC-03-005	D	Rc 1/2	M6	385	365	155	16.7
	U	1/2 NPT	1/4-20 UNC				
MMC-03-006	D	Rc 1/2	M6	460	440	230	20.0
	U	1/2 NPT	1/4-20 UNC				
MMC-03-007	D	Rc 1/2	M6	535	515	230	23.3
	U	1/2 NPT	1/4-20 UNC				
MMC-03-008	D	Rc 1/2	M6	610	590	305	26.6
	U	1/2 NPT	1/4-20 UNC				
MMC-03-009	D	Rc 1/2	M6	685	665	305	N/A
	U	1/2 NPT	1/4-20 UNC				
MMC-03-010	D	Rc 1/2	M6	760	740	380	35.5
	U	1/2 NPT	1/4-20 UNC				



SOLTECH

MODULAR(STACK) CONTROLS

MOUNTING BOLTS KITS(DIN 912/ ANSI-ASME B18.3)

【 MBK-02 】

HEXAGON SOCKET HEAD CAP SCREW
(DIN 912/ ANSI-ASME B18.3)

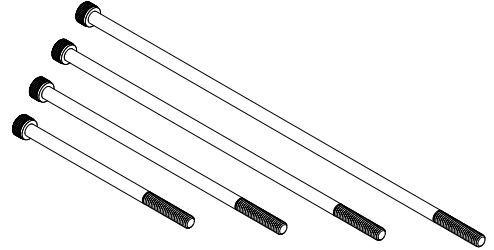

B

※MODEL NUMBER DESIGNATION

MBK	02	2	(90)
SERIES NO.	PORT SIZE 02: NG6	NO. OF VALVES 1, 2, 3, 4, 5	OMIT: DIN 912 BOLTS 90: UNC BOLT(NORTH AMERICA)

※SPECIFICATION

MODEL	MATERIAL	TENSILE STRENGTH	HARDNESS
MBK-02	SCM 435	180 KSi < 1/2" (1220n/mm ²)	HRC 39-45

※MOUNTING BOLTS

CODE	NO. OF VALVES	DIN BOLTS	UNC BOLTS	WEIGHT g(lbs)
MBK-02-01-※	1	M5×45Lg×4pcs	10-24UNC×1-3/4"Lg×4pcs	60(0.13)
MBK-02-02-※	2	M5×85Lg×4pcs	10-24UNC×3-3/8"Lg×4pcs	100(0.22)
MBK-02-03-※	3	M5×125Lg×4pcs	10-24UNC×5"Lg×4pcs	130(0.29)
MBK-02-04-※	4	M5×165Lg×4pcs	10-24UNC×6-1/2"Lg×4pcs	160(0.35)
MBK-02-05-※	5	M5×205Lg×4pcs	10-24UNC×8-1/8"Lg×4pcs	190(0.42)

【 MBK-03 】

HEXAGON SOCKET HEAD CAP SCREW
(DIN 912/ ANSI-ASME B18.3)

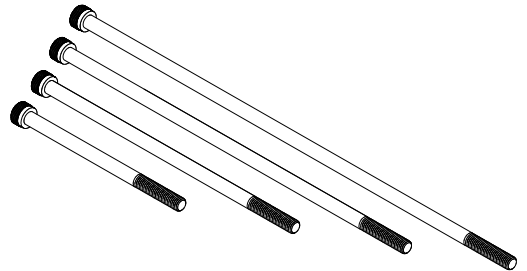

※MODEL NUMBER DESIGNATION

MBK	03	02	(90)
SERIES NO.	PORT SIZE 03: NG10	NO. OF VALVES 1, 2, 3, 4, 5	OMIT: DIN 912 BOLTS 90: UNC BOLT(NORTH AMERICA)

※SPECIFICATION

MODEL	MATERIAL	TENSILE STRENGTH	HARDNESS
MBK-03	SCM 435	180 KSi < 1/2" (1220n/mm ²)	HRC 39-45

※MOUNTING BOLTS

CODE	NO. OF VALVES	DIN BOLTS	UNC BOLTS	WEIGHT g(lbs)
MBK-03-01-※	1	M6×35Lg×4pcs	1/4-20UNC×1-1/2"Lg×4pcs	120(0.26)
MBK-03-02-※	2	M6×90Lg×4pcs	1/4-20UNC×3-5/8"Lg×4pcs	160(0.35)
MBK-03-03-※	3	M6×145Lg×4pcs	1/4-20UNC×5-3/4"Lg×4pcs	200(0.44)
MBK-03-04-※	4	M6×200Lg×4pcs	1/4-20UNC×7-1/2"Lg×4pcs	240(0.53)
MBK-03-05-※	5	M6×255Lg×4pcs	1/4-20UNC×10-1/8"Lg×4pcs	280(0.62)